

# TC-K215/K315

## SERVICE MANUAL

UK Model  
TC-K215

AEP Model  
E Model  
Australian Model  
TC-K315



Photo: TC-K315 model

Dolby noise reduction and HX Pro headroom extension manufactured under license from Dolby Laboratories Licensing Corporation. HX Pro originated by Bang & Olufsen.

"DOLBY", the double-D symbol  $\square\square$  and "HX PRO" are trademarks of Dolby Laboratories Licensing Corporation.

Model Name Using Similar Mechanism		TC-K311
Tape Transport	TC-K215	TCM-190VB22CS
Mechanism Type	TC-K315	TCM-190VB12CS

### SPECIFICATIONS

Recording system 4-track 2-channel stereo  
Fast winding time Approx. 90 sec. (with Sony C-60 cassette)  
Bias AC bias  
Heads Erasing head x 1 (F&F head)  
Playback/Recording head x 1 (SD head)  
Motors Capstan motor x 1 (DC servo motor)  
Reel motor x 1 (DC motor)

Signal-to-noise ratio (at peak level and weighted)

Cassette (Dolby NR off)	Type IV	Type II	Type I
	58 dB	57 dB	55 dB

Measured at peak level weighted without NR. The S/N is improved by about 15 dB at 500 Hz and by about 20 dB at 1 kHz with Dolby-C NR on, and by about 5 dB at 1 kHz and by about 10 dB at 5 kHz with Dolby-B NR on.

Harmonic distortion 0.4% (with Type I, 160 nWb/m, 315 Hz, 3rd H.D.)  
1.8% (with Type IV, 250 nWb/m, 315 Hz, 3rd H.D.)

Frequency response (Dolby NR off)

Type IV cassette	30 – 15,000 Hz ( $\pm 3$ dB, IEC)
Type II cassette	30 – 13,000 Hz [ $\pm 3$ dB, (-4 dB recording)]
Type I cassette	30 – 15,000 Hz ( $\pm 3$ dB, IEC)
Type I cassette	30 – 14,000 Hz ( $\pm 3$ dB, IEC)

Type IV : Sony Type IV (METAL)

Type II : Sony Type II (HIGH)

Type I : Sony Type I (NORMAL)

Wow and flutter  $\pm 0.13\%$  W.Peak (IEC)  
0.07% W.RMS (NAB)  
 $\pm 0.18\%$  W.Peak (DIN)

### Inputs

Line inputs (phono jacks)	Sensitivity	0.16 V
	Input impedance	47 k ohms

### Outputs

Line outputs (phono jacks)	Rated output level	0.5 V at a load impedance of 47 k ohms
	Load impedance	Over 10 k ohms
Headphones (stereo phone jack)	Output level	1 mW at a load impedance of 32 ohms

### General

#### Power requirements

AEP, German,  
East European model : 220—230 V AC, 50/60 Hz  
UK model : 240 V AC, 50 Hz  
Australian model : 240 V AC, 50/60 Hz  
E model : 110—120 or 220—240 V AC adjustable,  
50/60 Hz

#### Power consumption

19 W

#### Dimensions

Approx. 430 x 123 x 310 mm (w/h/d)  
including projecting parts and controls

#### Mass

Approx. 3.6 kg

### Supplied accessories

Audio connecting cords (2)

Design and specifications are subject to change without notice.



STEREO CASSETTE DECK  
**SONY**®

## TABLE OF CONTENTS

<u>Section</u>	<u>Title</u>	<u>Page</u>
<b>1. GENERAL</b>	.....	3
<b>2. DISASSEMBLY</b>		
2-1.	Front Panel .....	4
2-2.	Mechanism Deck .....	4
2-3.	Head .....	5
2-4.	Fitting Base Block .....	5
2-5.	Motor .....	5
<b>3. ADJUSTMENT</b>	.....	6
<b>4. DIAGRAMS</b>		
4-1.	IC PIN Function .....	9
4-2.	Block Diagram .....	11
4-3.	Circuit Boards Location .....	14
4-4.	Semiconductor Lead Layouts .....	14
4-5.	Printed Wiring Boards — Audio Section — .....	14
4-6.	Schematic Diagram — Audio Section — .....	17
4-7.	Schematic Diagram — Audio System Control Section — .....	21
4-8.	Printed Wiring Boards — Audio System Control Section — .....	25
<b>5. EXPLODED VIEWS</b>		
5-1.	Chassis Section .....	28
5-2.	Front Panel Section .....	29
5-3.	Mechanism Section-1 .....	30
5-4.	Mechanism Section-2 .....	31
<b>6. ELECTRICAL PARTS LIST</b>	.....	32

## MODEL IDENTIFICATION

— Specification Labels —

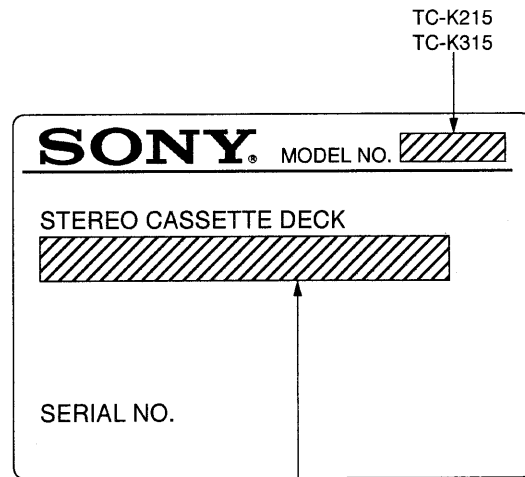



AEP, German, East European model : AC 220—230V~50/60Hz 19W

UK, Australian model : AC 240V~50/60Hz

E model : AC 110—120, 220—240V~50/60Hz 19W

### SAFETY-RELATED COMPONENT WARNING!!

COMPONENTS IDENTIFIED BY MARK  OR DOTTED LINE WITH MARK  ON THE SCHEMATIC DIAGRAMS AND IN THE PARTS LIST ARE CRITICAL TO SAFE OPERATION. REPLACE THESE COMPONENTS WITH SONY PARTS WHOSE PART NUMBERS APPEAR AS SHOWN IN THIS MANUAL OR IN SUPPLEMENTS PUBLISHED BY SONY.

## SECTION 1 GENERAL

This section is extracted  
from instruction manual.

### Identifying the Parts on the Front Panel

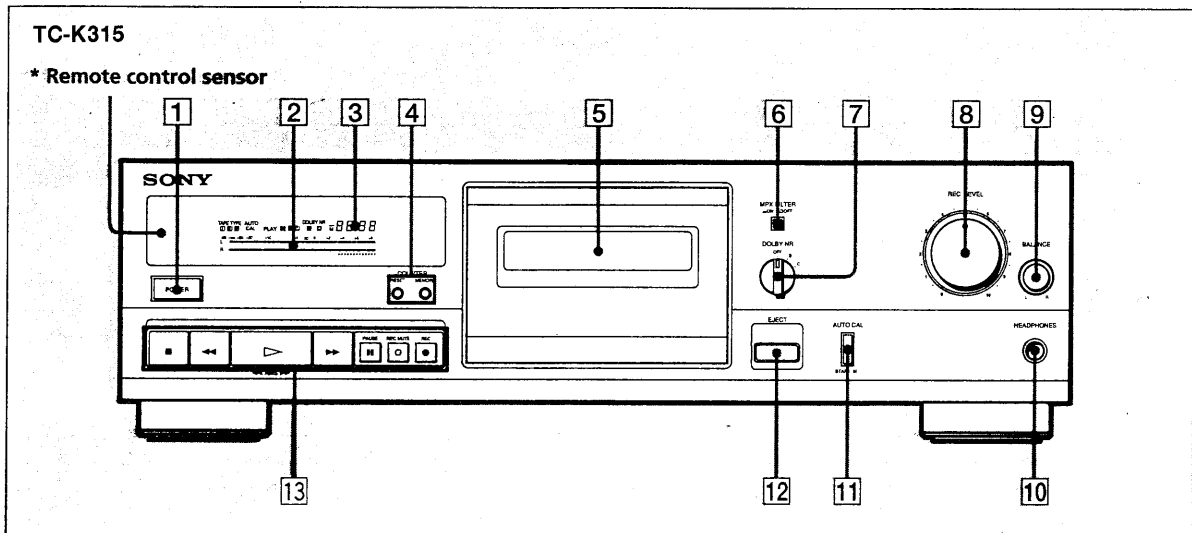



For details, refer to the page number(s) indicated in parentheses.

- 1 POWER switch
- 2 Peak level meter (page 12)
- 3 Digital counter (page 9)
- 4 COUNTER buttons  
RESET button (page 9)  
MEMORY button (pages 9 and 10)
- 5 Cassette holder
- 6 MPX FILTER button (page 12)
- 7 DOLBY NR (noise reduction) switch (pages 7 and 10)
- 8 REC (recording) LEVEL control (pages 11 and 12)
- 9 BALANCE control (page 11)
- 10 HEADPHONES jack (stereo phone jack) (page 7)
- 11 AUTO CAL button (page 13) : TC-K315
- 12 △ (EJECT) button
- 13 Tape operation buttons  
■ (stop) button  
◀◀ (rewind) (Multi-AMS\*\*) button  
▷ (play) button  
▶▶ (fast-forward) (Multi-AMS\*\*) button  
⏸ PAUSE button  
○ REC MUTE (record muting) button (page 14)  
● REC (recording) button

#### \* Remote control sensor

You can remotely control this cassette deck with:

- A remote commander that came with a Sony amplifier or receiver if it has the  mark and cassette deck control capability.
- An optional Sony remote commander with the  mark and cassette deck control capability.

\*\*AMS is an abbreviation for Automatic Music Sensor.

## SECTION 2 DISASSEMBLY

**NOTE:** Follow the disassembly procedure in the numerical order given.

### CASE

Unscrew the four case attachment screws M3×8 and remove the case.

### 2-1. FRONT PANEL

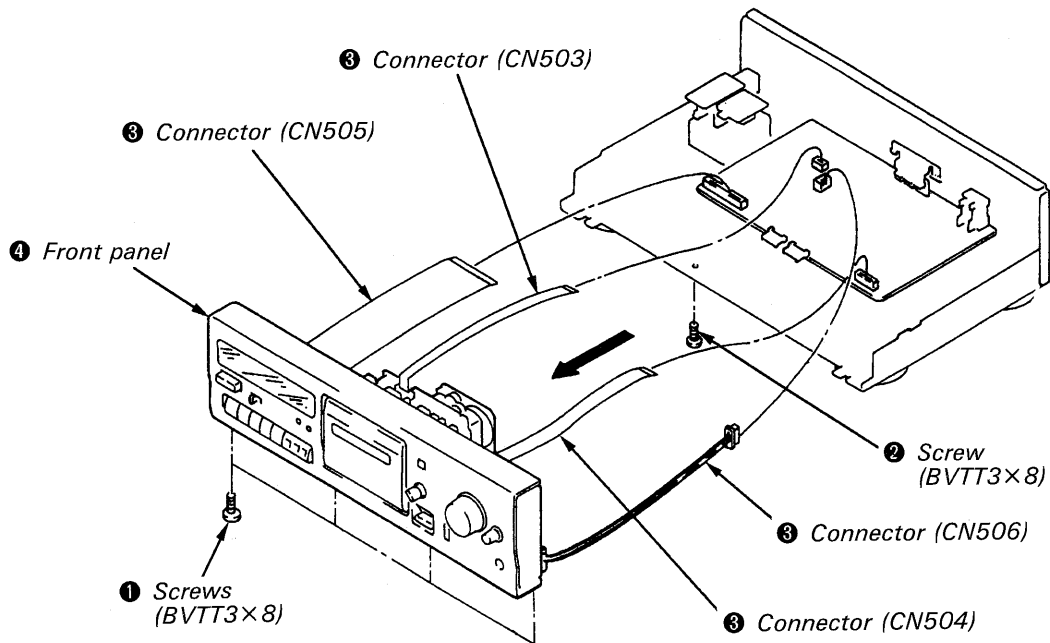

### 2-2. MECHANISM DECK

① Press the eject button.

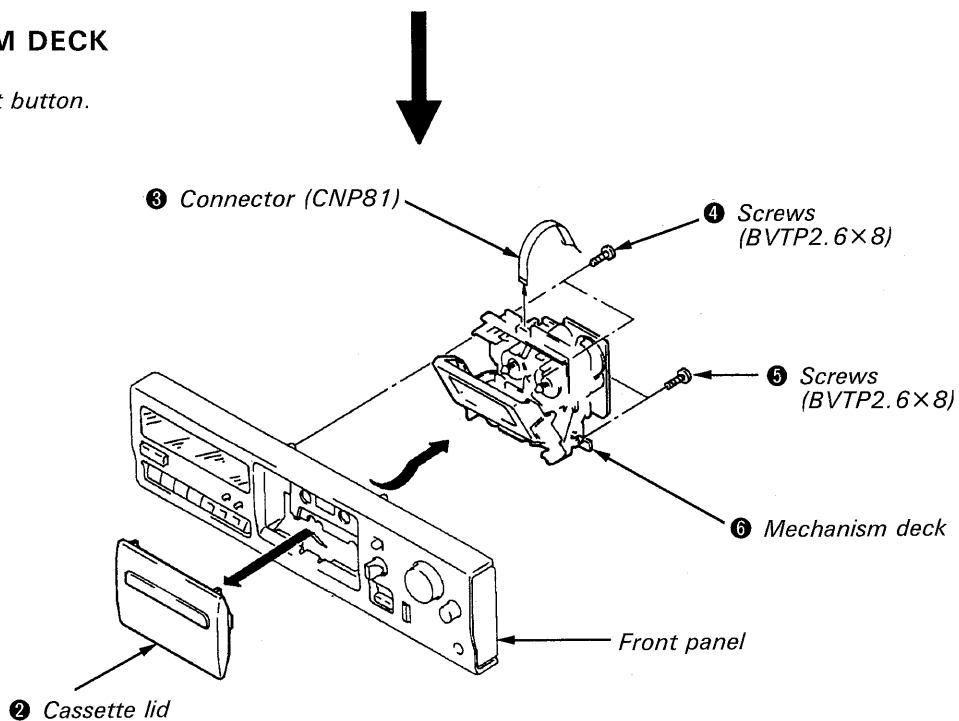

### 2-3. HEAD

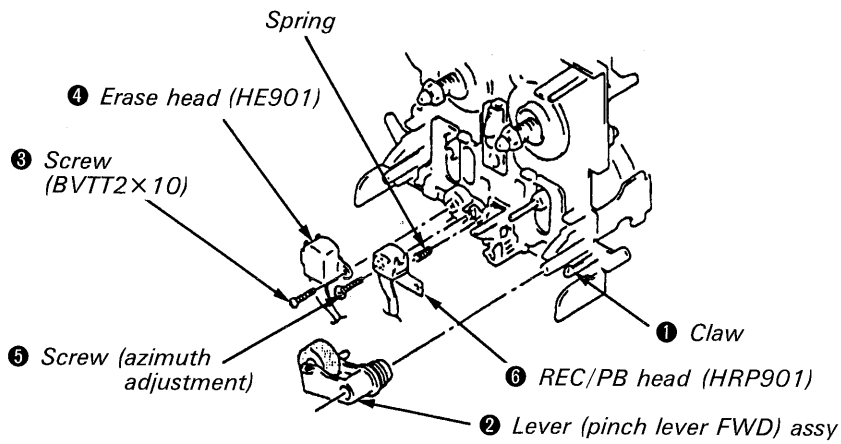

### 2-4. FITTING BASE BLOCK

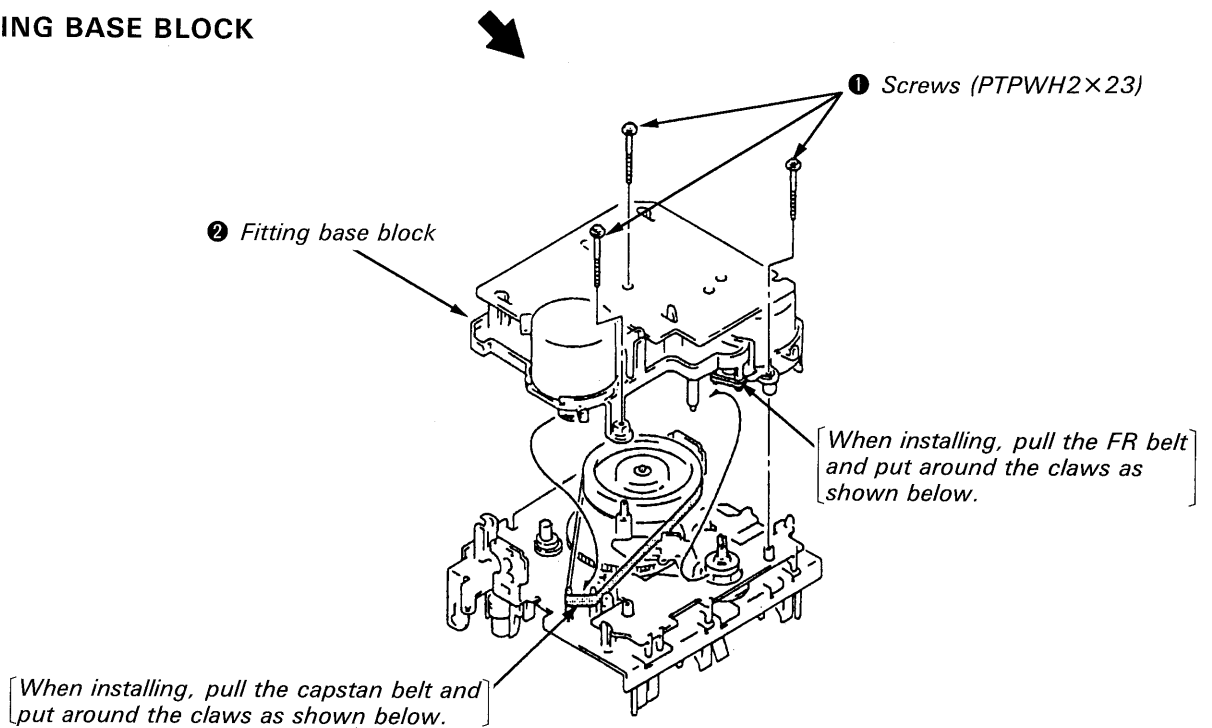

### 2-5. MOTOR

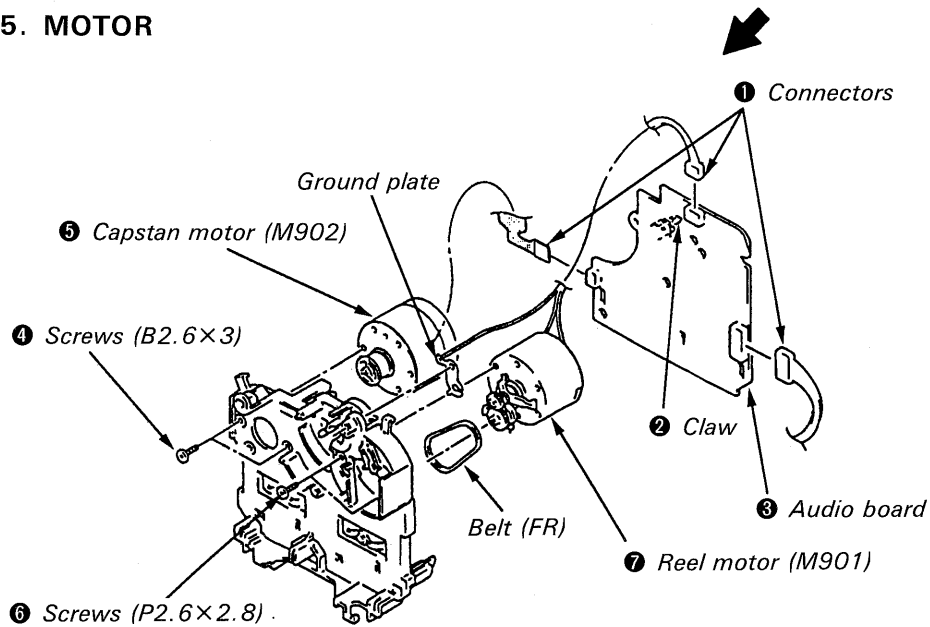

# SECTION 3 ADJUSTMENT

## 3-1. MECHANICAL ADJUSTMENTS

### PRECAUTION

1. Clean the following parts with a denatured alcohol-moistened swab:
 

record/playback/erase head	pinch roller
rubber belts	capstan
idlers	
2. Demagnetize the record/playback head with a head demagnetizer.
3. Do not use a magnetized screwdriver for the adjustment.
4. After the adjustments, apply suitable locking compound to the parts adjusted.
5. The adjustments should be performed with the rated power supply voltage unless otherwise noted.

### Torque Measurement

Torque	Torque	Meter reading
Forward	CQ-102C	30 to 65g•cm (0.42 to 0.9 oz•inch)
Forward back tension	CQ-102C	1 to 6g•cm (0.014 to 0.08 oz•inch)
FF/REW	CQ-201B	70 to 120g•cm (0.98 to 1.67 oz•inch)

## 3-2. ELECTRICAL ADJUSTMENTS

### PRECAUTION

1. The adjustment should be performed in the publication.  
(Be sure to make playback adjustment at first.)
2. The adjustments and measurement should be performed for both L-CH and R-CH.
  - Position of switches and control knobs  
DOLBY NR switch : OFF  
MPX FILTER switch : OFF  
BALANCE control : mechanical mid
  - Standard record position:  
Deliver the standard input signal level to input jack and set the REC LEVEL control to obtain the standard output signal level as follows.

— Record Mode —

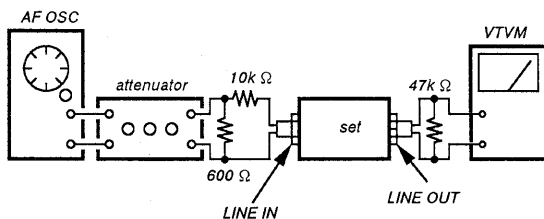

### Standard Input Level

Input terminal	LINE IN
source impedance	10k Ω
input signal level	0.5V ( - 3.8dB)

### Standard Output Level

Output terminal	LINE OUT
load impedance	47k Ω
output signal level	0.5V ( - 3.8dB)

### Test Tape

Tape	Contents	Use
P-4-A100	10kHz, - 10dB	Azimuth Adjustment
P-4-L300	315Hz, 0dB	PB Level Adjustment
WS-48B	3kHz, 0dB	Tape Speed Adjustment

0dB=0.775V

### Test Mode

1. Insert a short-circuit plug into TP801 (2P) and turn ON the power switch. (Earth pin ⑨ of IC801 and turn ON the power switch.)  
At first, all the fluorescent tubes light up, then the system returns to normal display. (However, "0000" is not displayed on the counter.)
2. To release the test mode, remove the short plug and turn off the power switch.
3. Remove the short plug after completion of adjustment.

### Record/Playback Head Azimuth Adjustment

#### Procedure :

1. Playback Mode

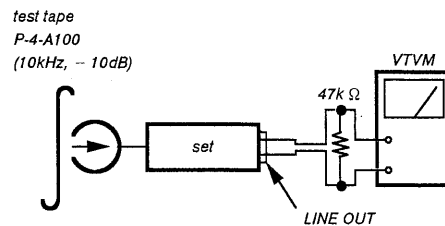

2. Turn the adjustment screw for the maximum output levels. If these levels do not match, turn the adjustment screw until both of output levels match together within 1dB.

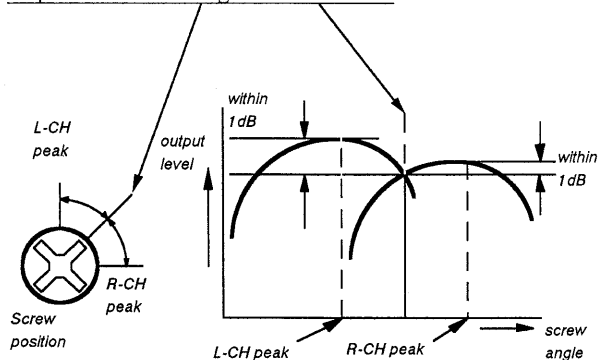

### 3. Playback Mode

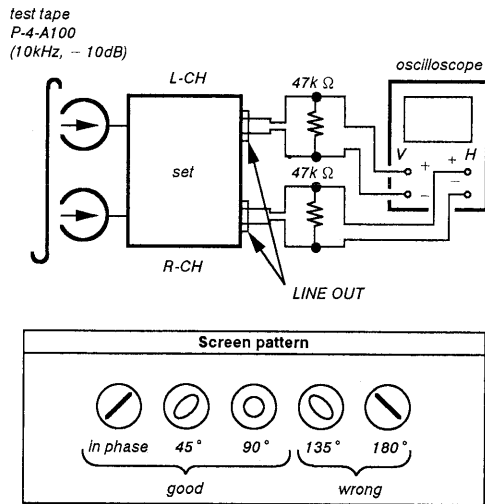

4. After the adjustment, lock the adjustment screws with suitable locking compound.

**Adjustment Location :** – record/playback head –

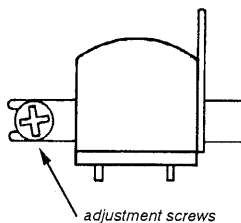

### Tape Speed Adjustment

**Procedure :**

– Playback Mode –

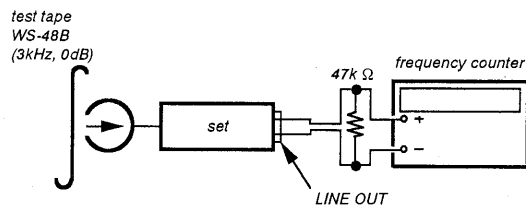

1. Adjust RV71 so that the frequency counter reading becomes  $3,000 \pm 10\text{Hz}$ .
2. If, the frequency counter reading does not become  $3000 \pm 10\text{Hz}$ . Turn RV72 and back to 1st. step again.

**Note:**

- Turn RV72 to clockwise – Tape speed becomes fast.
- Turn RV72 to counter clockwise – Tape speed becomes slow.

Frequency difference between the beginning and the end of the tape should be within 3%.

**Adjustment Location :** AUDIO board

### Playback Level Adjustment

**Procedure :**

– Playback Mode –

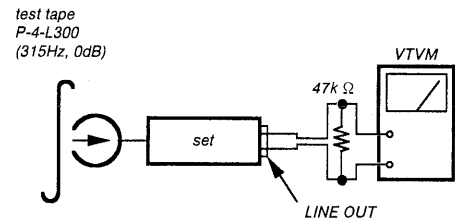

Adjust RV11(L-CH) and RV21(R-CH) so the VTVM reading becomes the adjustment limits below.

**Adjustment Value :**

LINE OUT level :  $-7.7 \pm 0.5\text{dB}$  (0.301 to 0.338V)

Level difference between channels : within 0.5dB

Confirm the LINE OUT level does not change in playback mode while changing the mode from playback to stop several times.

**Adjustment Location :** AUDIO board

### Bias Consumption Current Adjustment (TC-K315 only)

This adjustment should be performed when replacing the head assy or the bias oscillating transformer (T81, T91).

**Procedure :**

– Record Mode –

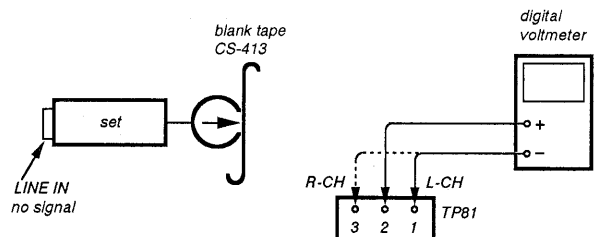

1. Connect the digital voltmeter to test point TP81.
2. Set RV81 (L-CH) and RV91 (R-CH) to mechanical center.
3. Set to record mode.
4. Adjust T81 (L-CH) and T91 (R-CH) so that the digital voltmeter reading becomes minimum.

**Adjustment Location :** AUDIO board

## Record Bias Adjustment

### Setting :

REC LEVEL control : standard record position (Refer to page 6.)

### Procedure :

1. Record Mode

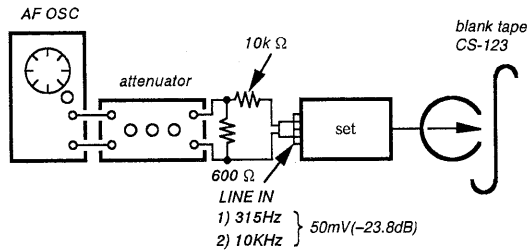

2. Playback Mode

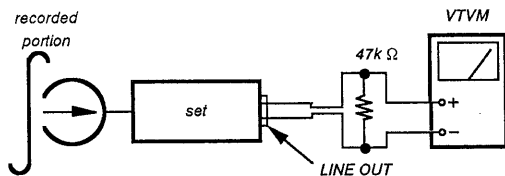

Confirm that the 10kHz playback output is  $0 \pm 0.5\text{dB}$  relative to the 315Hz output. If necessary, adjust semi-fixed resistor as shown below and repeat the steps given above.

TC-K215 : RV12 (L-CH), RV22 (R-CH)

TC-K315 : RV81 (L-CH), RV91 (R-CH)

Adjustment Location : AUDIO board

## Record Level Adjustment

### Setting :

REC LEVEL control : standard record position (Refer to page 6.)

### Procedure :

1. Record Mode

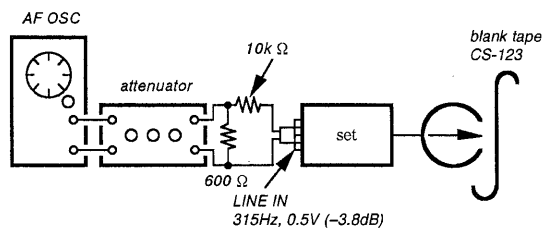

2. Playback Mode

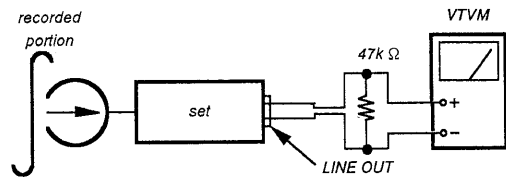

Confirm playback the tape recorded become adjustment level as follows.

If necessary, adjust RV111(L-CH), RV211(R-CH) and repeat the steps 1 and 2.

### Adjustment Value :

LINE OUT level :  $-3.8 \pm 0.5\text{dB}$  (0.47 to 0.53V)

Adjustment Location : SYSTEM CONTROL

### — Adjustment Parts Location Diagrams —

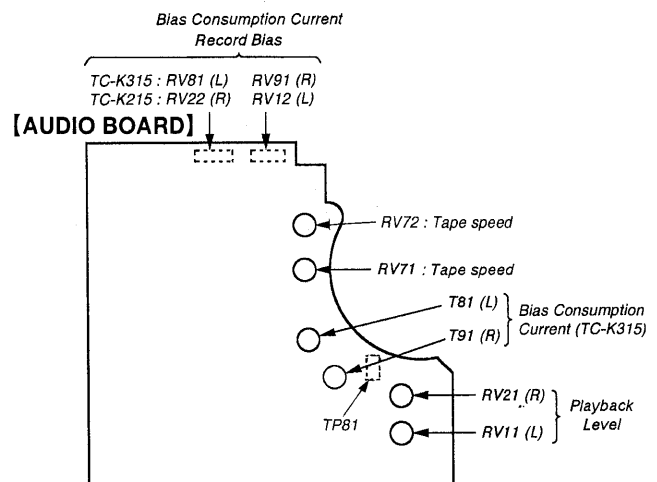
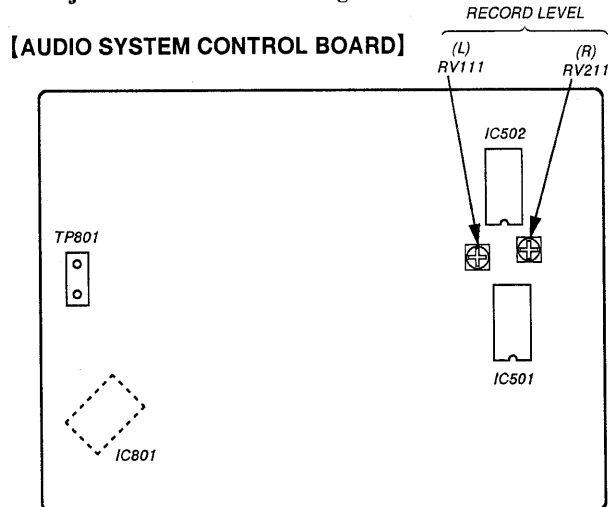



## SECTION 4 DIAGRAMS

### 4-1. IC PIN FUNCTION

#### IC801 CXP82316-014Q

Pin No.	Pin name	I/O	Description
1	STOP SW	I	Mechanism stop switch input terminal.
2	SIRCS	I	SIRCS signal in terminal.
3	NC	—	Not used.
4	—	—	
5	—	—	
6	MPX KEY	I	MPX Key ON/OFF switch input terminal. OFF = 0V
7	MPX ON/OFF	O	MPX Filter ON/OFF control terminal. OFF = L
8	CAL ON/OFF	O	Calibration ON/OFF control terminal.
9	REC CAL0	I	REC calibration terminal.
10	REC CAL1	I	REC calibration terminal.
11	GP CAL0	I	GP calibration terminal.
12	GP CAL1	I	GP calibration terminal.
13	—	—	
14	LINE MUTE	O	Line mute ON/OFF. 0V =Mute
15	REC/PB	O	Recording/Playback selector for dolby IC select.
16	REC MUTE	O	REC out mute terminal.
17	REEL —	O	Reel motor — control terminal.
18	REEL +	O	Reel motor + control terminal.
19	BIAS	O	Bias ON/OFF.
20	RELAY	O	Relay selector, terminal
21	CAL KEY	I	Calibration ON/OFF switch input terminal. ON = 0V
22	KEY X	I	Key switch input terminal.
23	KEY Y	I	Key switch input terminal.
24	METER L	I	Meter level Lch.
25	METER R	I	Meter level Rch.
26	DOLBY	I	Dolby OFF/B/C select terminal.
27	HALF	I	Half pawl input terminal.
28	AMS	I	AMS signal input terminal.
29	S • REEL	I	Suplly pulse input terminal.
30	RESET	I	Reset terminal. Reset = 0V
31	XO	O	System clock input terminal.
32	XI	I	System clock output terminal.
33	GND	—	Power supply (GND)
34	BIAS CAL0	O	Bias calibration terminal.
35	BIAS CAL1	O	Bias calibration terminal.
36	BIAS CAL2	O	Bias calibration terminal.
37	BIAS CAL3	O	Bias calibration terminal.
38	CAP • M ON/OFF	O	Capstan motor. ON/OFF control.
39	NC	—	Not used.
40	OSC ON/OFF	O	OSC ON/OFF control.

Pin No.	Pin name	I/O	Description
41	OSC H/L	O	OSC H/L control.
42	NC	–	Not used.
43	NC	–	Not used.
44	NC	–	Not used.
45	NC	–	Not used.
46	S1	O	FL Segment.
47	S2	O	FL Segment.
48	S3	O	FL Segment.
49	S4	O	FL Segment.
50	S5	O	FL Segment.
51	S6	O	FL Segment.
52	S7	O	FL Segment.
53	S8	O	FL Segment.
54	S9	O	FL Segment.
55	S10	O	FL Segment.
56	S11	O	FL Segment.
57	S12	O	FL Segment.
58	S13	O	FL Segment.
59	S14	O	FL Segment.
60	S15	O	FL Segment.
61	S16	O	FL Segment.
62	S18	O	FL Segment.
63	NC	–	Not used.
64	NC	–	Not used.
65	NC	–	Not used.
66	G5	O	FL Grid.
67	G4	O	FL Grid.
68	G3	O	FL Grid.
69	G2	O	FL Grid.
70	G1	O	FL Grid.
71	– 20V	–	– 20V.
72	+5V	–	Power supply (+5V)
73	+5V	–	Power supply (+5V)
74	METAL	I	Metal tape selector terminal. “H” : Metal
75	CrO <sub>2</sub>	I	CrO <sub>2</sub> tape select terminal. “H” : CrO <sub>2</sub>
76	POWER IN	I	0V = Power OFF
77	POWER OUT	O	Power ON/OFF. ON = 0V
78	NC	–	Not used.
79	TEST	I	Test mode selector. 5V = Normal, 0V = Test mode
80	VER	I	Version selector. “H” : Reverse “L” : 1 way

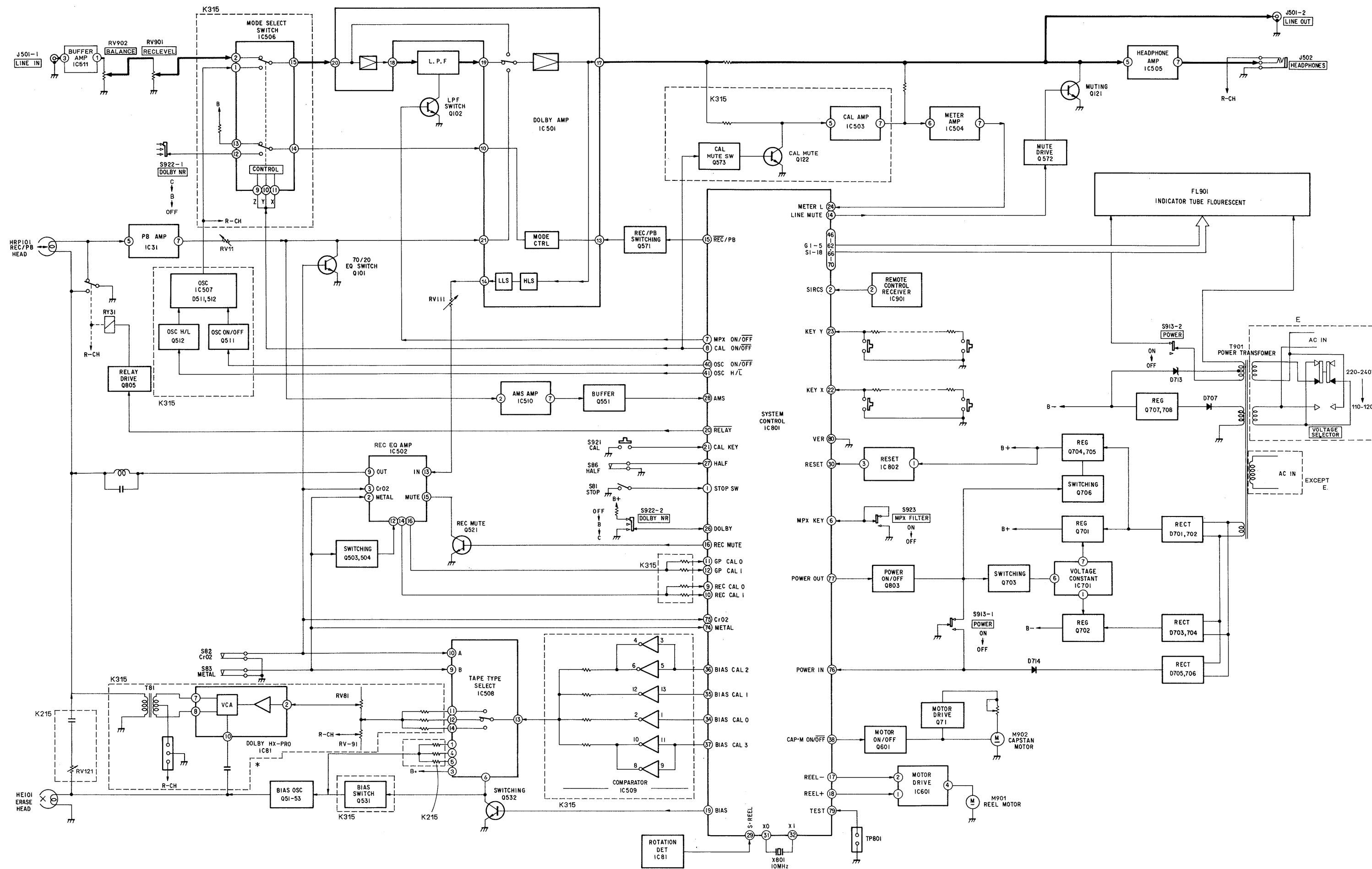

4-3. CIRCUIT BOARDS LOCATION

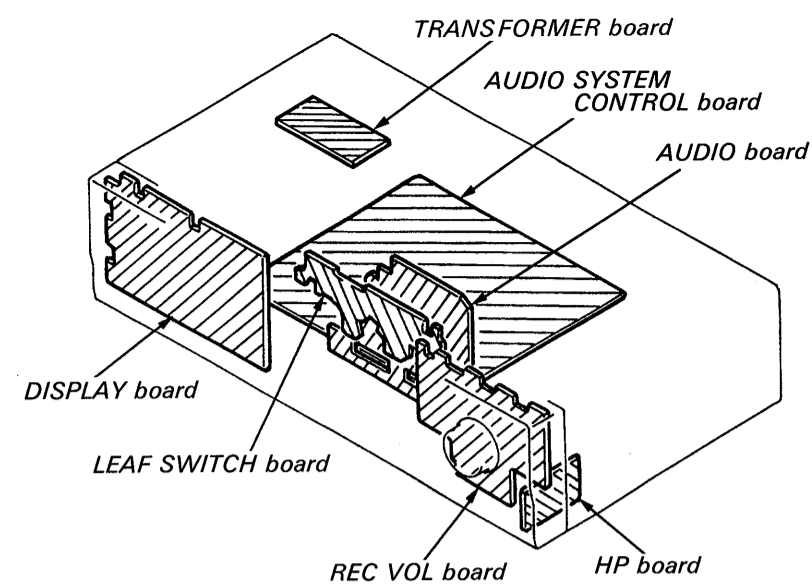

4-4. SEMICONDUCTOR LEAD LAYOUTS

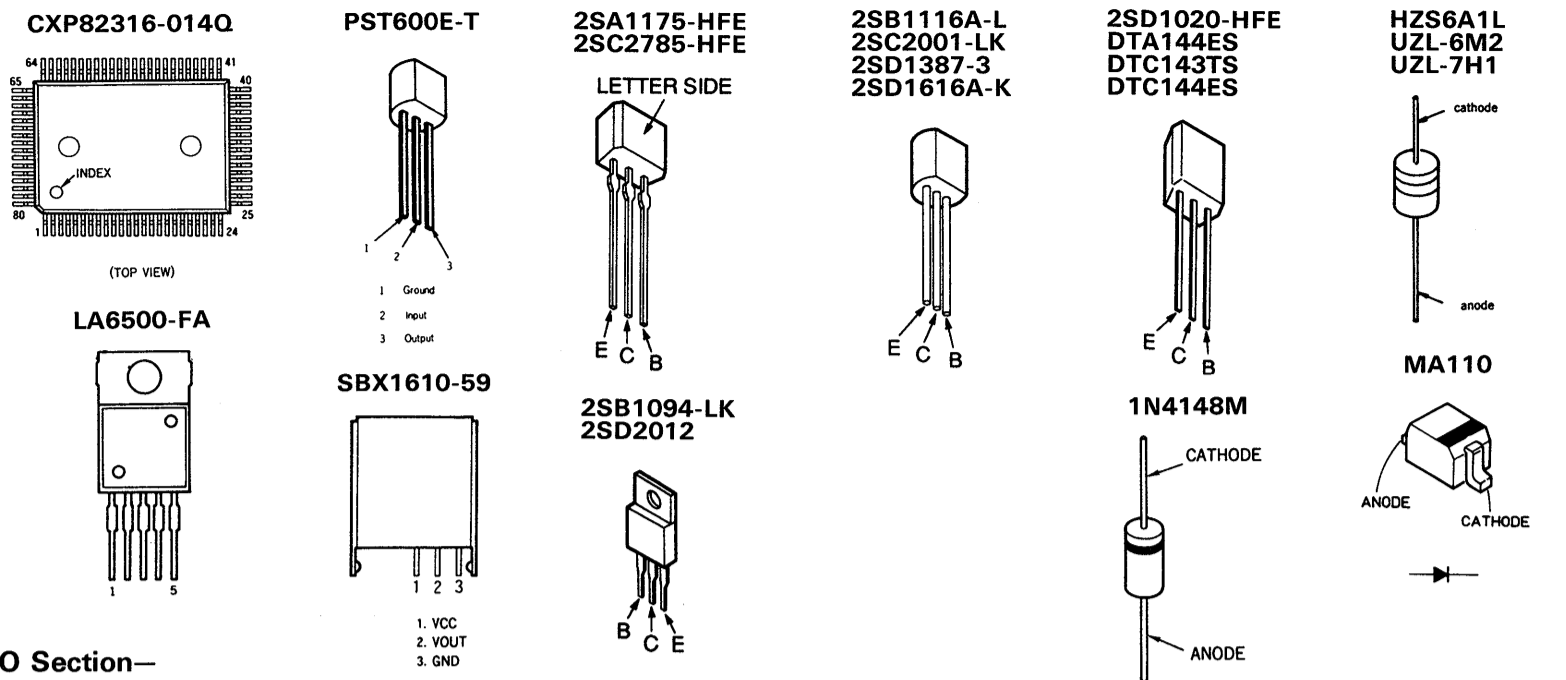

Note:  
 ○ : parts extracted from the component side.  
 ● : Through hole.  
 ◐ : Pattern on the side which is seen.  
 ◑ : Pattern of the rear side.

4-5. PRINTED WIRING BOARDS —AUDIO Section—

● Semiconductor Location

Ref. No.	Location
D31 (K215)	I - 7
D31 (K315)	C - 8
IC31 (K215)	I - 8
IC31 (K315)	C - 8
IC81 (LEAF SW BOARD)	H - 14
IC81 (BOARD)	B - 9
IC901	C - 18
Q51 (K215)	H - 9
Q51 (K315)	B - 8
Q52 (K215)	H - 9
Q52 (K315)	B - 8
Q53 (K215)	H - 9
Q53 (K315)	B - 8
Q71 (K215)	I - 10
Q71 (K315)	C - 10

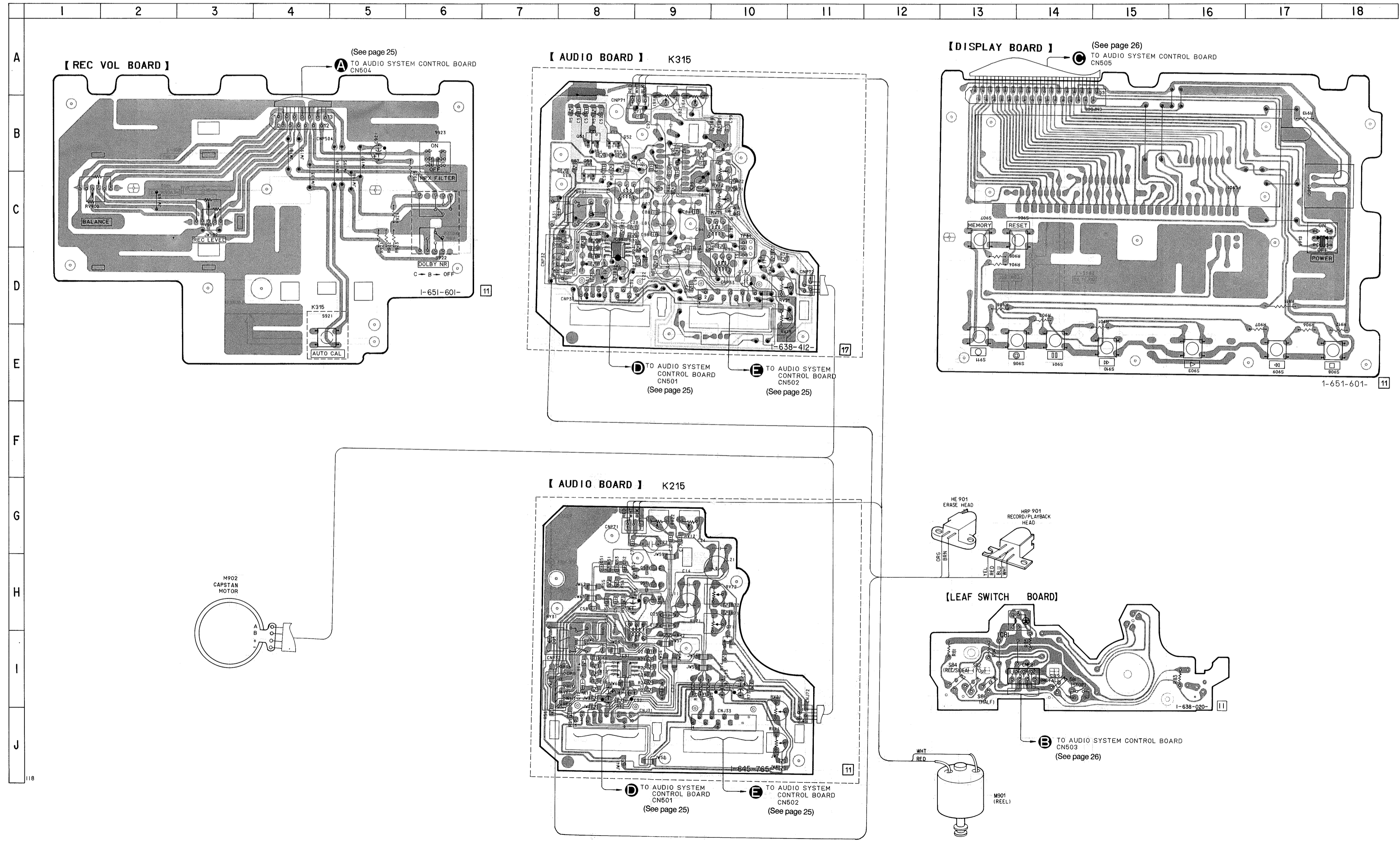

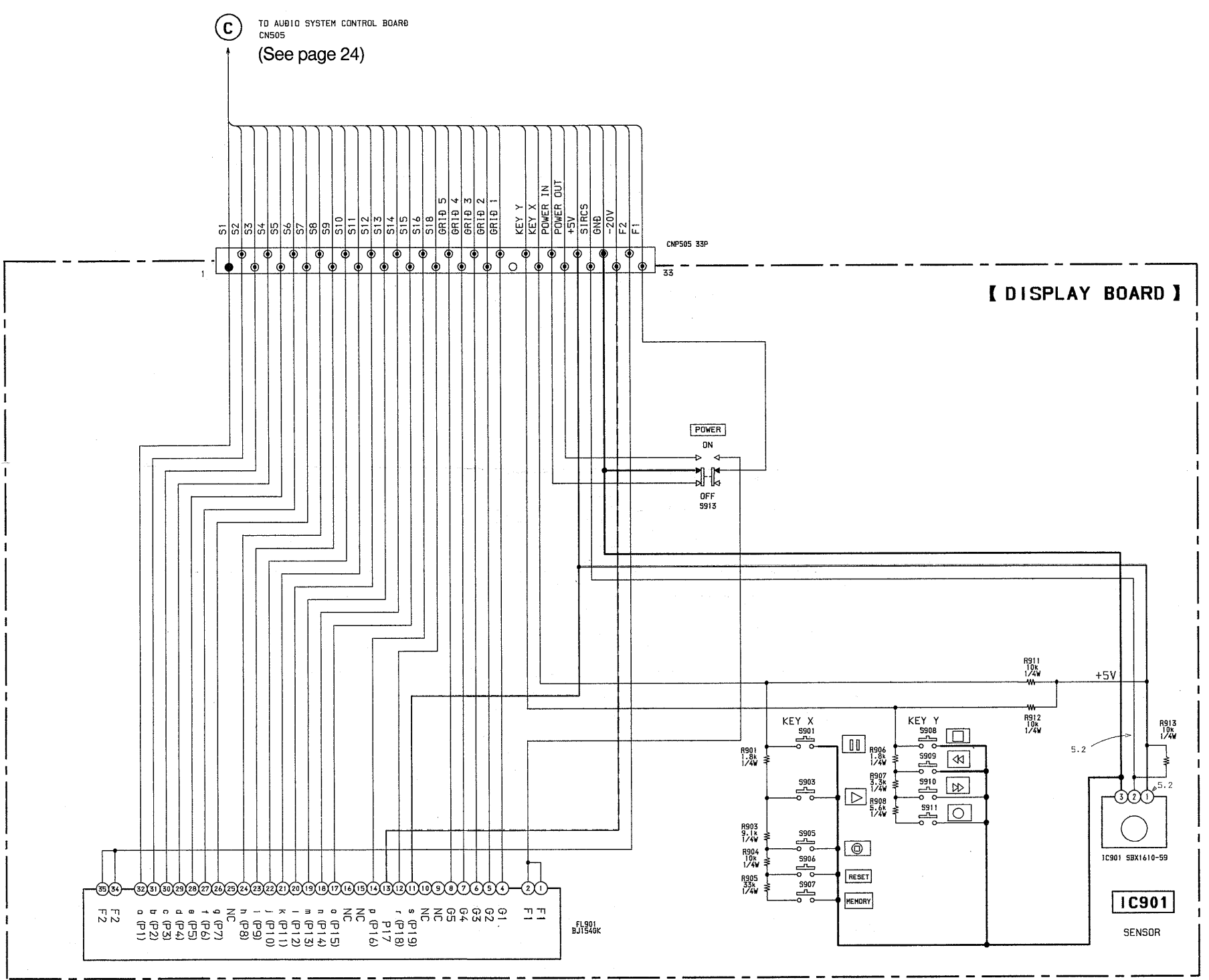
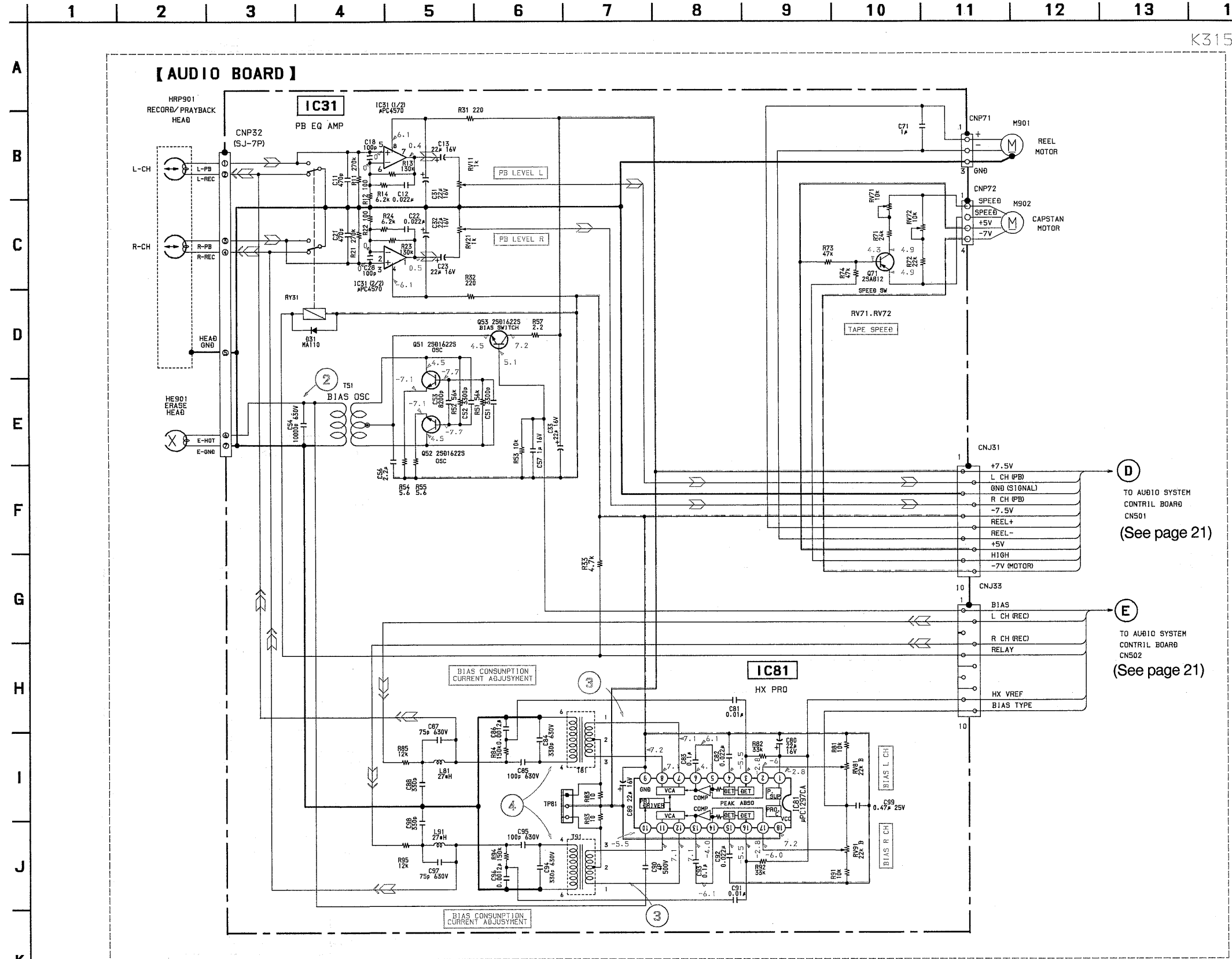

Waveforms

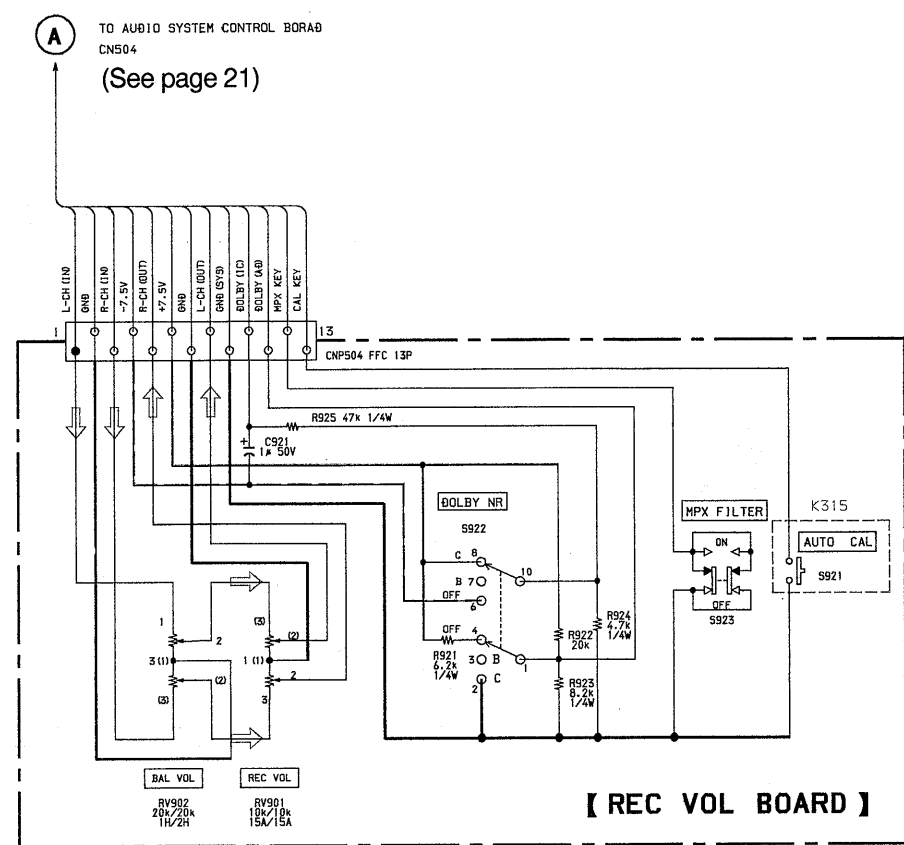
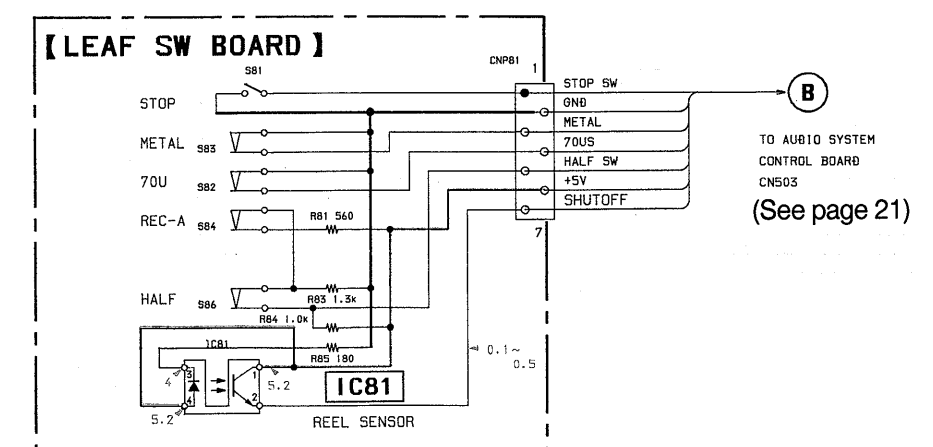
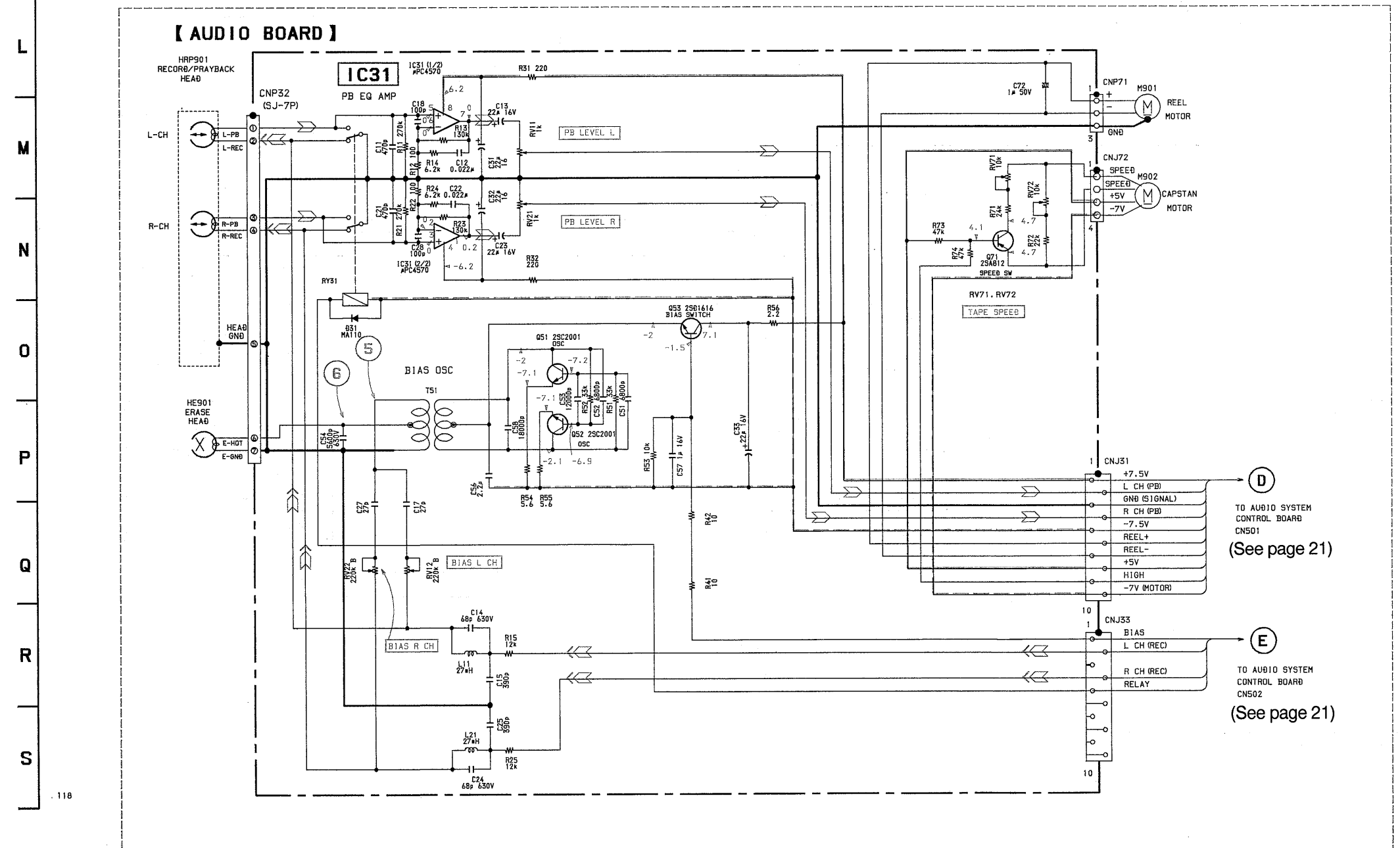
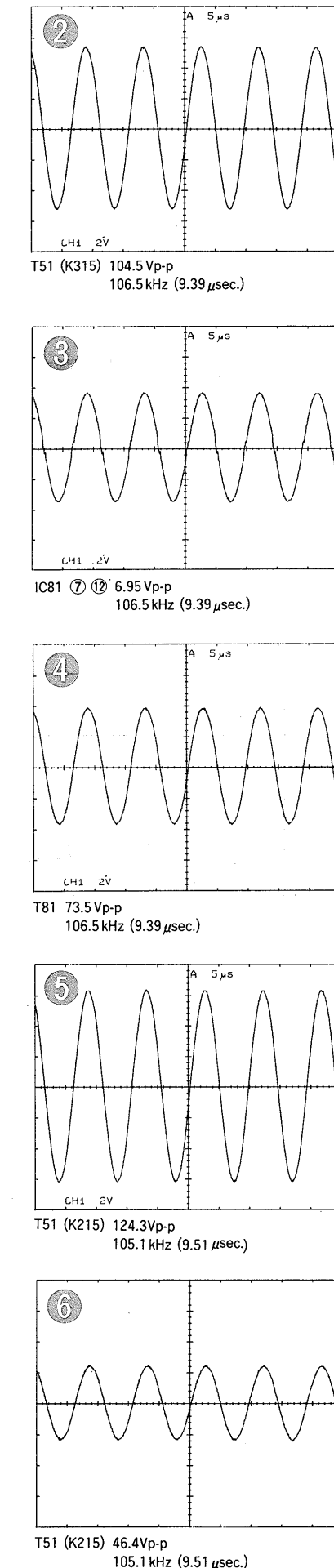

**Note:**

- All capacitors are in μF unless otherwise noted. pF: μF 50WV or less are not indicated except for electrolytics and tantalums.
- All resistors are in Ω and 1/4W or less unless otherwise specified.
- △ : internal component.
- : B+ Line
- : B- Line
- ▭ : adjustment for repair.
- Voltage and waveforms are dc with respect to ground under no-signal (detuned) conditions.
- Volts are taken with a VOM (Input Impedance 10MΩ). Voltage variations may be noted due to normal production tolerances.
- Waveforms are taken with an oscilloscope. Voltage variations may be noted due to normal production tolerances.
- Circled numbers refer to waveforms.
- ◁ : LINE ▷ : PB ▷▷ : REC

4-7. SCHEMATIC DIAGRAM —AUDIO SYSTEM CONTROL Section—

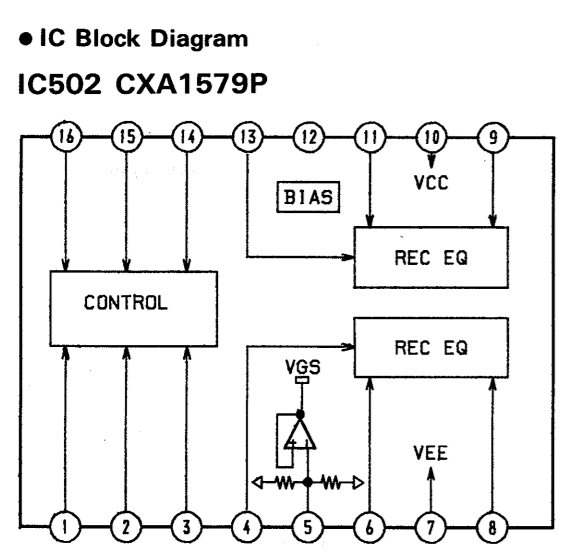
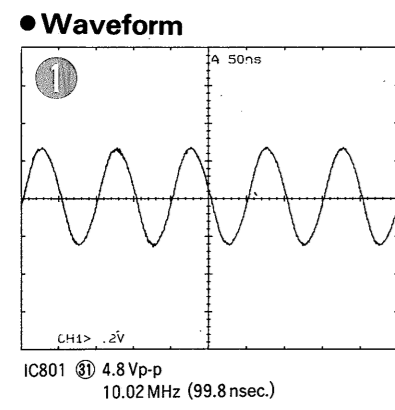
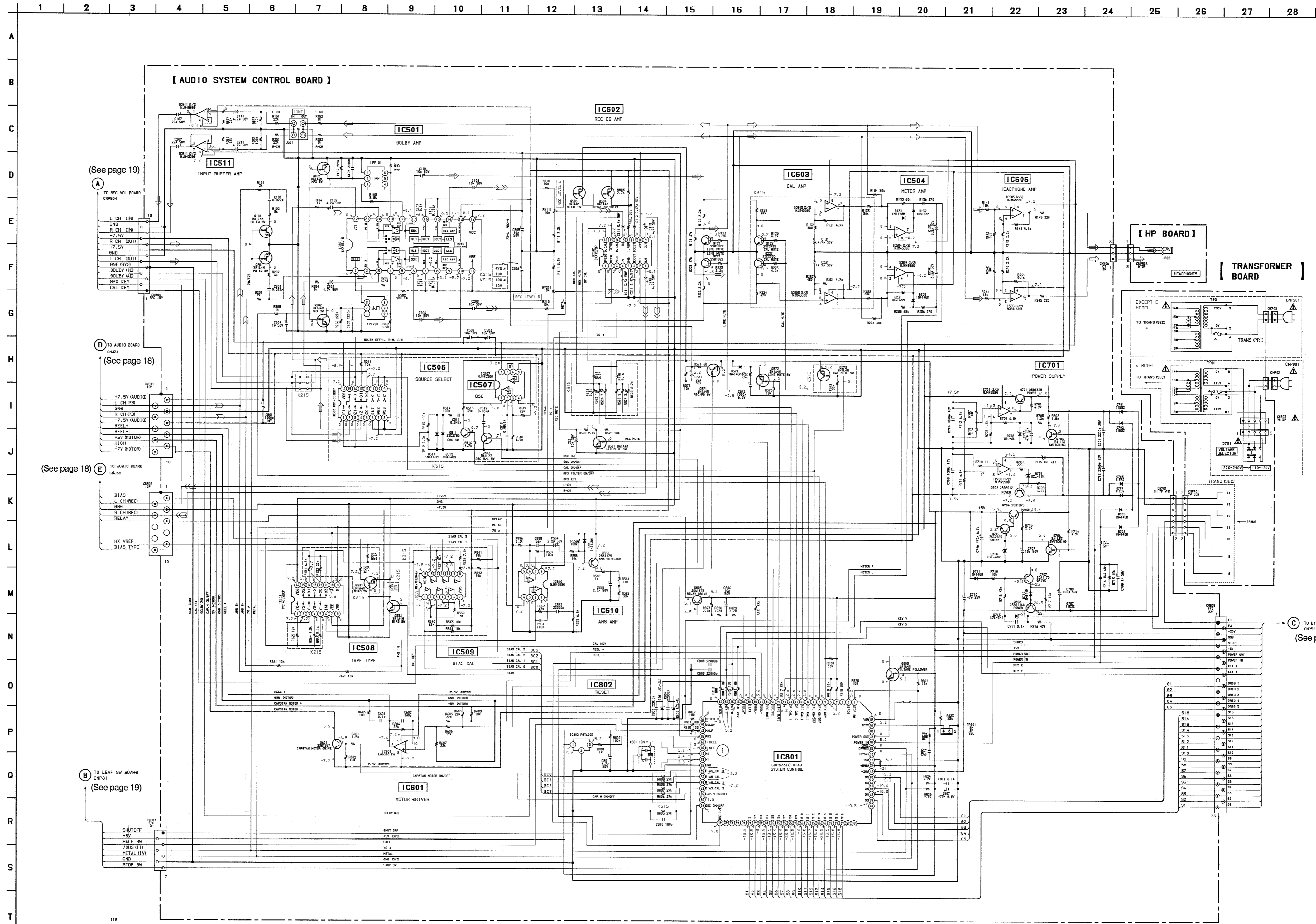

- Note:**
- All capacitors are in  $\mu\text{F}$  unless otherwise noted. pF:  $\mu\text{F}$ F 50WV or less are not indicated except for electrolytics and tantalums.
  - All resistors are in  $\Omega$  and  $\frac{1}{4}\text{W}$  or less unless otherwise specified.
  - $\Delta$ : internal component.
- Note:** The components identified by mark  $\Delta$  or dotted line with mark  $\Delta$  are critical for safety. Replace only with part number specified.
- : B+ Line
  - ◻ : B- Line
  - ◻ : adjustment for repair.
  - : Voltage and waveforms are dc with respect to ground under no-signal (detuned) conditions.
  - : Voltages are taken with a VOM (Input Impedance 10M $\Omega$ ). Voltage variations may be noted due to normal production tolerances.
  - : Waveforms are taken with an oscilloscope. Voltage variations may be noted due to normal production tolerances.
  - : Circled numbers refer to waveforms.
  - ◁ : LINE ▷ : PB
  - ◁▷ : REC

4-8. PRINTED WIRING BOARDS —AUDIO SYSTEM CONTROL Section— ● See page 14 for Circuit Boards Location. ● See page 14-15 for Semiconductor Lead Layouts.

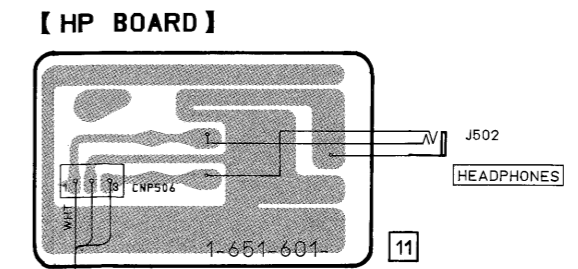
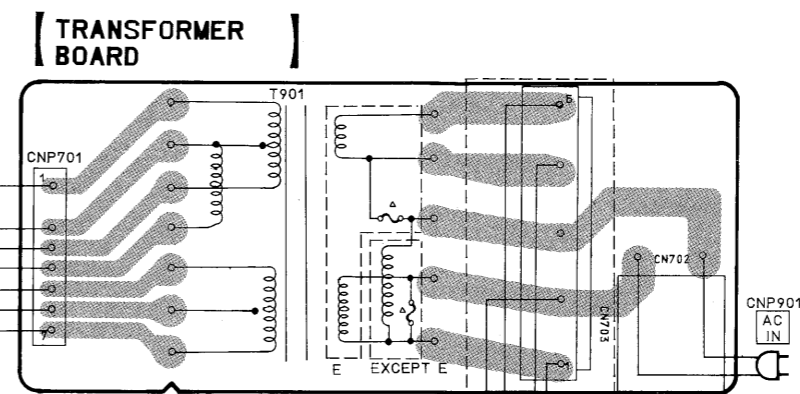
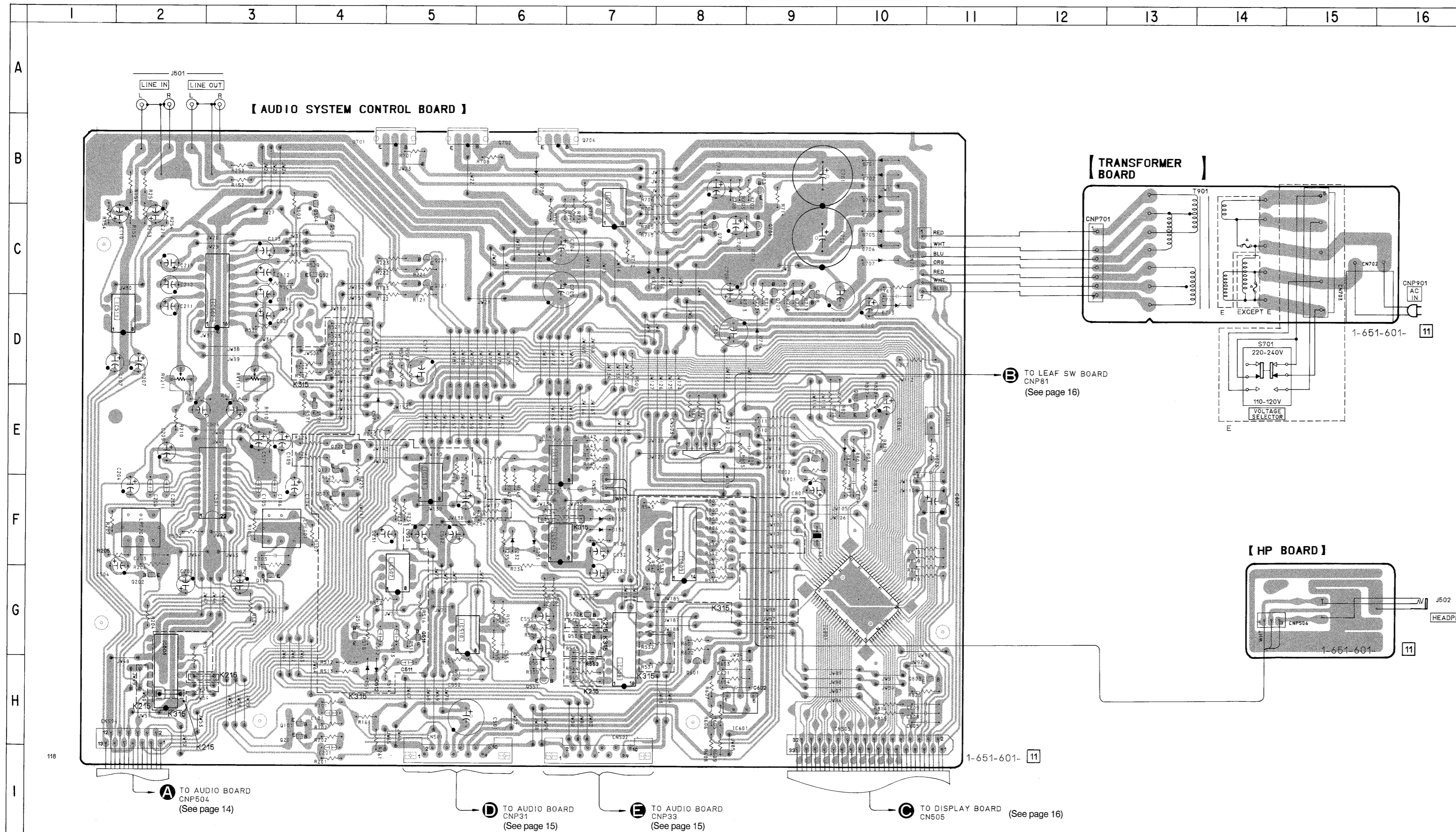

● Semiconductor Location

Ref. No.	Location	Ref. No.	Location
D131	F - 7	IC511	D - 2
D132	F - 7	IC601	H - 8
D231	F - 6	IC701	C - 7
D232	F - 6	IC801	G - 10
D511	H - 4	IC802	E - 9
D512	H - 4		
D551	H - 6	Q101	H - 4
D571	E - 4	Q102	G - 2
D701	B - 10	Q121	C - 5
D702	B - 10	Q122	E - 4
D703	C - 10	Q201	H - 4
D704	B - 10	Q202	G - 2
D705	C - 10	Q221	C - 5
D706	C - 10	Q222	E - 4
D707	C - 10	Q503	C - 4
D708	B - 8	Q504	C - 4
D709	B - 6	Q511	G - 5
D710	C - 9	Q512	G - 4
D711	C - 8	Q521	C - 4
D712	C - 9	Q531	G - 7
D713	D - 10	Q532	G - 7
D714	D - 9	Q551	H - 6
D715	C - 7	Q571	E - 4
D801	E - 10	Q572	D - 5
D802	E - 10	Q573	F - 4
		Q601	H - 8
		Q701	B - 5
IC501	F - 3	Q702	B - 5
IC502	C - 3	Q703	B - 9
IC503	F - 5	Q704	B - 6
IC504	F - 6	Q705	C - 8
IC505	E - 6	Q706	C - 9
IC506	H - 2	Q707	C - 9
IC507	G - 5	Q708	C - 9
IC508	G - 7	Q803	H - 11
IC509	F - 8	Q805	E - 10
IC510	G - 5		

Note:  
 ● — : parts extracted from the component side.  
 ● ● : Through hole.  
 ● : Pattern on the side which is seen.





## 5-2. FRONT PANEL SECTION

- B: DISPLAY board
- C: REC VOL board
- D: HP board

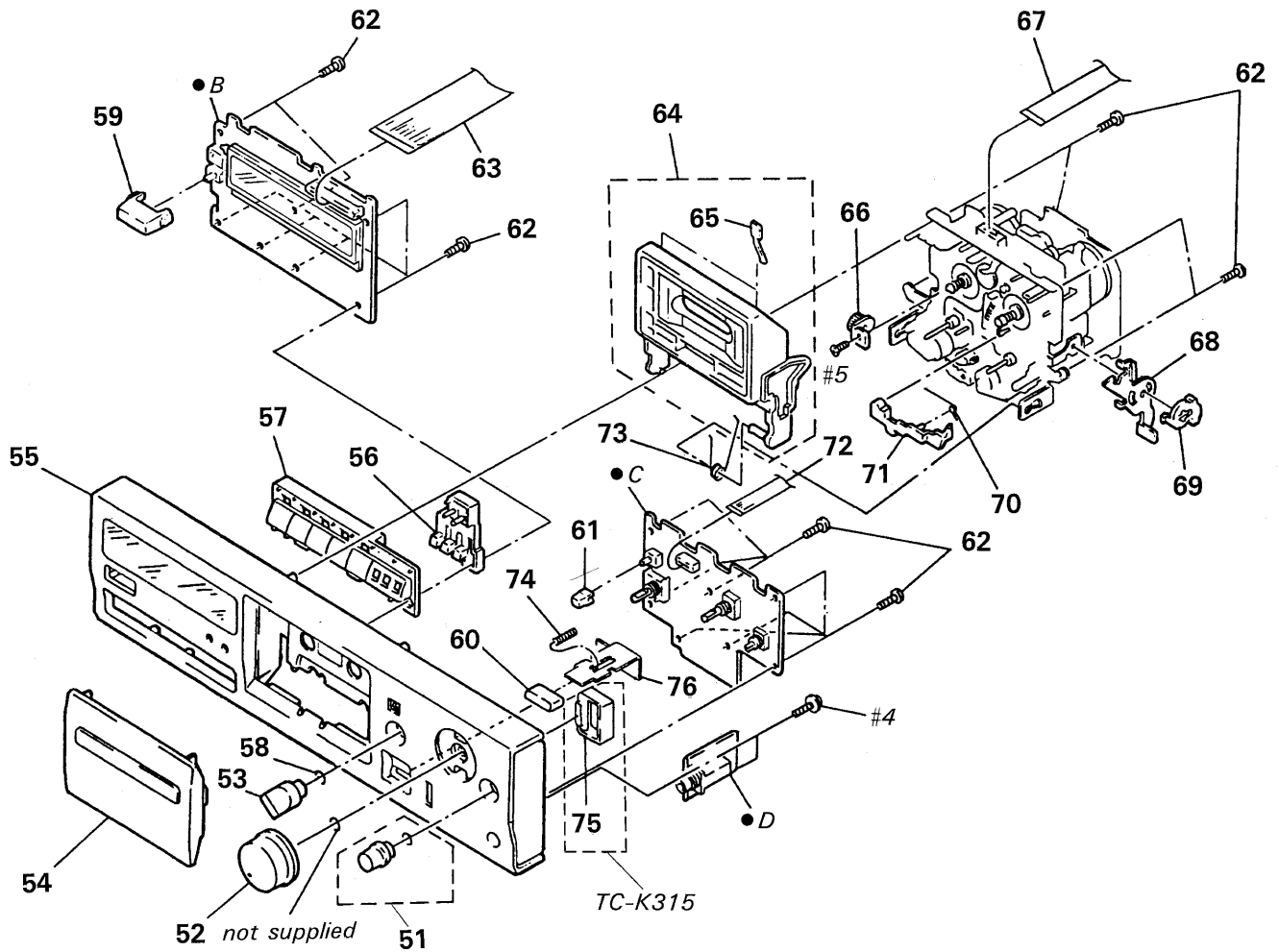

Ref.No.	Part No.	Description	Remark
51	X-3368-033-1	KNOB (RB) ASSY (BALANCE)	
52	3-389-516-01	KNOB (REC) (REC LEVEL)	
53	4-908-097-21	KNOB (DOLBY NR)	
54	X-3367-877-1	LID ASSY, CASSETTE (TC-K315)	
54	X-3368-168-1	LID ASSY, CASSETTE (TC-K215)	
55	X-3367-876-1	PANEL ASSY, FRONT (TC-K315)	
55	X-3367-878-1	PANEL ASSY, FRONT (TC-K215)	
56	3-386-248-11	BUTTON (RE) (PAUSE/REC MUTE/REC)	
57	3-386-247-11	BUTTON (FW) (STOP/REWIND/PLAY/FAST-FORWARD)	
58	3-350-440-11	SPRING, RING	
59	3-354-932-01	BUTTON (POWER)	
60	3-387-830-11	BUTTON (EJECT)	
61	3-380-952-21	BUTTON (MPX FILTER)	
62	4-951-620-01	SCREW (2.6X8), +BVTP	
63	1-751-736-11	WIRE (FLAT TYPE) (33 CORE)	

Ref.No.	Part No.	Description	Remark
64	A-2004-357-A	HOLDER (R) ASSY, CASSETTE (TC-K315)	
64	A-4325-164-A	HOLDER (R) ASSY, CASSETTE (TC-K215)	
65	3-308-823-11	DETENT, CASSETTE	
66	3-354-963-01	DAMPER	
67	1-696-965-11	WIRE (FLAT TYPE) (7 CORE)	
*68	3-354-954-01	LEVER (LOCK LEVER R)	
69	3-354-957-01	JOINT (LOCK LEVER)	
70	3-354-962-01	SPRING (EJ SAFTY SPRING R)	
71	3-354-956-01	LEVER (EJ SAFTY LEVER R)	
72	1-534-517-00	WIRE (FLAT TYPE) (13 CORE)	
73	3-354-960-01	SPRING (LOADING R), TORSION	
74	3-359-906-11	SPRING, COMPRESSION	
75	3-387-834-31	BUTTON (MBC) (AUTO CAL) (TC-K315)	
76	3-387-833-11	SLIDER (EJECT)	

**5-3. MECHANISM SECTION-1**  
**(TCM-190VB12CS : TC-K315)**  
**(TCM-190VB22CS : TC-K215)**

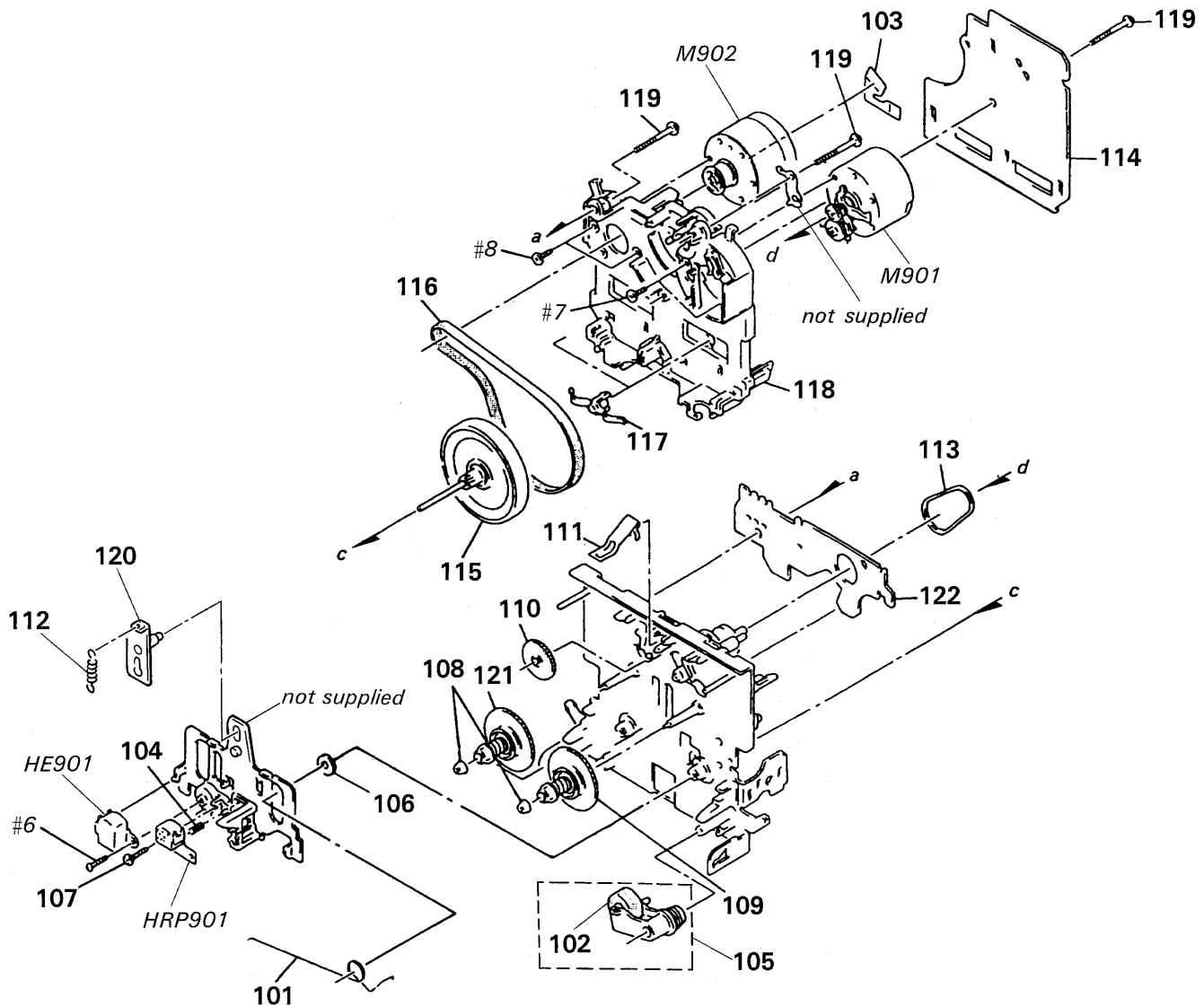

Ref.No.	Part No.	Description	Remark	Ref.No.	Part No.	Description	Remark
101	3-359-455-01	SPRING, TORSION (TC-K215)		* 114	A-2006-890-A	AUDIO BOARD, COMPLETE (TC-K315)	
101	3-907-362-01	SPRING, TORSION (TC-K315)		* 114	A-2007-171-A	AUDIO BOARD, COMPLETE (TC-K215)	
102	3-355-808-21	PINCH ROLLER		115	X-3367-629-1	FLYWHEEL (FWD) ASSY	
103	1-638-983-11	MOTOR FLEXIBLE BOARD		116	3-359-467-01	BELT (1 WAY FLAT BELT)	
104	3-343-484-01	SPRING, COMPRESSION		117	3-575-321-00	RETAINER, THRUST, CAPSTAN	
105	X-3366-047-1	LEVER (PINCH F) ASSY		118	3-359-436-11	BASE (THRUST RETAINER), FITTING	
106	3-356-713-01	WASHER		119	3-359-414-01	SCREW (+PTPWH 2X23)	
107	3-378-262-01	SCREW (AZIMUTH)		* 120	X-3362-589-2	SLIDER (LIMITER) ASSY	
108	3-362-308-01	CAP (REEL) (TC-K215)		121	X-3366-971-1	TABLE ASSY (B), REEL	
108	3-913-841-01	CAP (REEL) (TC-K315)		* 122	1-638-020-11	LEAF SW BOARD	
109	X-3366-970-1	TABLE ASSY, REEL		HE901	1-543-673-11	HEAD, MAGNETIC (ERASE)	
110	3-359-424-01	GEAR (REV GEAR)		HRP901	1-543-919-11	HEAD, MAGNETIC (RECORD/PLAYBACK)	
111	3-359-430-01	SPRING (CASSETTE RETAINER), LEAF		M901	X-3363-501-1	MOTOR ASSY, REEL	
112	3-363-868-01	SPRING (HEAD CHASSIS), TENSION		M902	X-3365-377-1	MOTOR ASSY, CAPSTAN	
113	3-359-466-01	BELT (FR), SQUARE					

**5-4. MECHANISM SECTION-2**  
 (TCM-190VB12CS : TC-K315)  
 (TCM-190VB22CS : TC-K215)

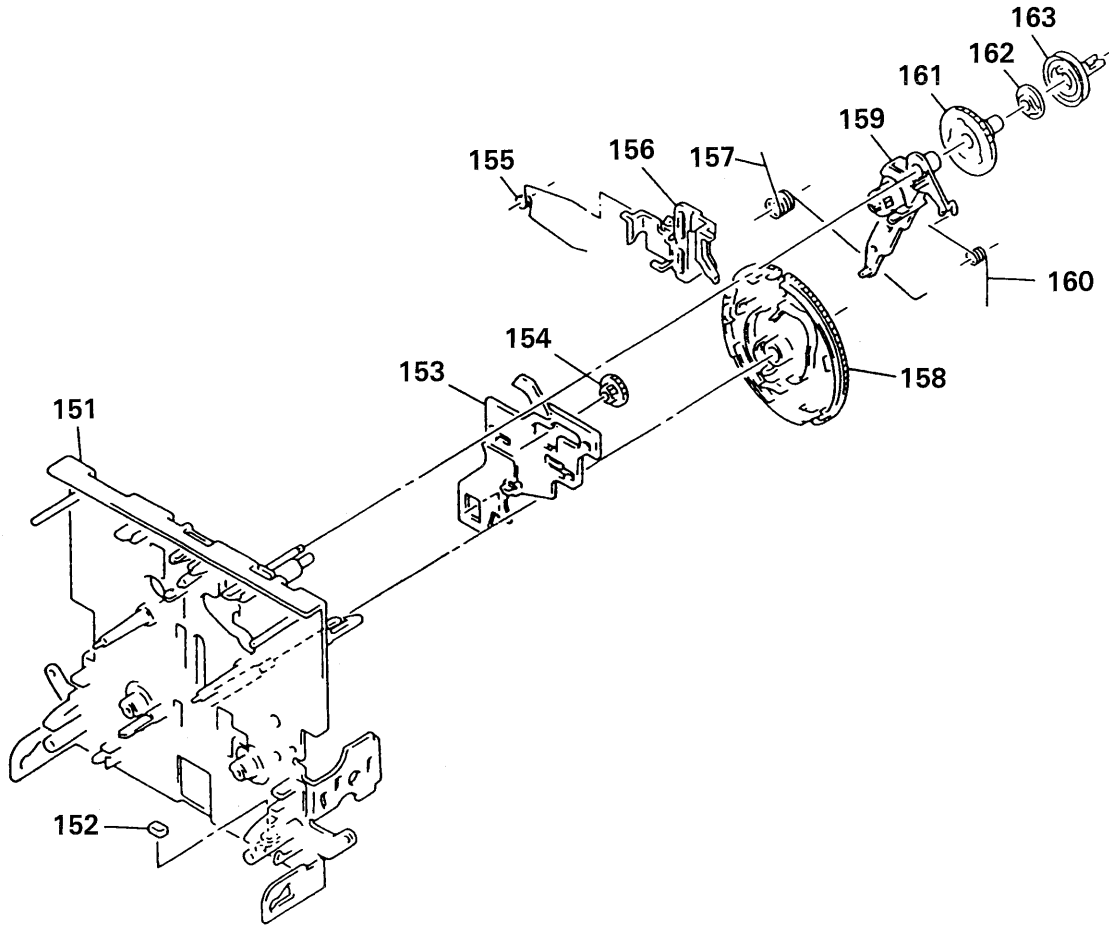

Ref.No.	Part No.	Description	Remark
151	X-3359-416-1	CHASSIS (ONE) ASSY, MECHANICAL	
152	3-359-469-01	SPACER	
* 153	3-359-415-01	SLIDER (TRIGGER SLIDER)	
154	3-359-448-01	GEAR (TRIGGER)	
155	3-359-454-01	SPRING, TORSION	
156	3-359-429-01	SLIDER (BRAKE PLATE)	
157	3-359-456-01	SPRING (TRIGGER SPRING), TORSION	

Ref.No.	Part No.	Description	Remark
158	3-359-420-01	GEAR (CAM GEAR)	
159	X-3366-569-1	ARM ASSY, FR	
160	3-359-453-01	SPRING (FR ARM), TORSION	
161	3-359-419-11	GEAR (FR GEAR)	
162	3-359-421-01	CLUTCH (REEL DISK) (TC-K215)	
162	3-359-421-11	CLUTCH (REEL DISK) (TC-K315)	
163	3-359-418-11	PULLEY (FR PULLEY)	

# SECTION 6 ELECTRICAL PARTS LIST

## AUDIO

**NOTE:**

● Due to standardization, replacements in the parts list may be different from the parts specified in the diagrams or the components used on the set.

● -XX and -X mean standardized parts, so they may have some difference from the original one.

● **RESISTORS**

All resistors are in ohms.  
**METAL:** Metal-film resistor.  
**METAL OXIDE:** Metal oxide-film resistor.  
**F:** nonflammable

● Items marked "\*" are not stocked since they are seldom required for routine service. Some delay should be anticipated when ordering these items.

● **SEMICONDUCTORS**

In each case, u :  $\mu$ , for example:  
 uA... :  $\mu$ A..., uPA... :  $\mu$ PA..., uPB... :  $\mu$ PB...,  
 uPC... :  $\mu$ PC..., uPD... :  $\mu$ PD...

● **CAPACITORS**

uF :  $\mu$ F

● **COILS**

uH :  $\mu$ H

● **Abbreviations**

**G:** German  
**EE:** East European  
**AUS:** Australian

The components identified by mark  $\triangle$  or dotted line with mark  $\triangle$  are critical for safety. Replace only with part number specified.

When indicating parts by reference number, please include the board.

Ref.No.	Part No.	Description	Remark
*	A-2007-171-A	AUDIO BOARD, COMPLETE (K215) *****	
		< CAPACITOR >	
C11	1-163-133-00	CERAMIC CHIP 470PF	5% 50V
C12	1-136-157-00	FILM 0.022uF	5% 50V
C13	1-124-234-00	ELECT 22uF	20% 16V
C14	1-136-272-00	FILM 68PF	5% 630V
C15	1-164-080-11	CERAMIC 390PF	10% 50V
C17	1-163-103-00	CERAMIC CHIP 27PF	5% 50V
C18	1-163-117-00	CERAMIC CHIP 100PF	5% 50V
C21	1-163-133-00	CERAMIC CHIP 470PF	5% 50V
C22	1-136-157-00	FILM 0.022uF	5% 50V
C23	1-124-234-00	ELECT 22uF	20% 16V
C24	1-136-272-00	FILM 68PF	5% 630V
C25	1-164-080-11	CERAMIC 390PF	10% 50V
C27	1-163-103-00	CERAMIC CHIP 27PF	5% 50V
C28	1-163-117-00	CERAMIC CHIP 100PF	5% 50V
C31	1-124-234-00	ELECT 22uF	20% 16V
C32	1-124-234-00	ELECT 22uF	20% 16V
C33	1-124-234-00	ELECT 22uF	20% 16V
C51	1-163-019-00	CERAMIC CHIP 0.0068uF	10% 50V
C52	1-163-019-00	CERAMIC CHIP 0.0068uF	10% 50V
C53	1-163-022-00	CERAMIC CHIP 0.012uF	10% 50V
C54	1-136-560-11	FILM 0.0056uF	5% 630V
C56	1-164-505-11	CERAMIC CHIP 2.2uF	16V
C57	1-164-346-11	CERAMIC CHIP 1uF	16V
C58	1-163-024-00	CERAMIC CHIP 0.018uF	10% 50V
C72	1-124-499-11	ELECT, NONPOLAR 1uF	20% 50V
		< CONNECTOR >	
*CNJ31	1-580-782-11	CONNECTOR, BOARD TO BOARD	
*CNJ33	1-580-782-11	CONNECTOR, BOARD TO BOARD	
*CNJ72	1-580-411-11	SOCKET, CONNECTOR 4P	
*CNP32	1-580-781-11	PIN, CONNECTOR (PC BOARD) 7P	
*CNP71	1-564-719-11	PIN, CONNECTOR (SMALL TYPE) 3P	

Ref.No.	Part No.	Description	Remark
		< DIODE >	
D31	8-719-404-46	DIODE MA110	
		< IC >	
IC31	8-759-106-02	IC UPC4570G2	
		< JUMPER RESISTOR >	
JW1	1-216-296-91	METAL GLAZE 0	5% 1/8W
JW2	1-216-295-00	METAL CHIP 0	5% 1/10W
JW3	1-216-295-00	METAL CHIP 0	5% 1/10W
JW4	1-216-295-00	METAL CHIP 0	5% 1/10W
JW6	1-216-295-00	METAL CHIP 0	5% 1/10W
JW7	1-216-295-00	METAL CHIP 0	5% 1/10W
JW52	1-216-296-91	METAL GLAZE 0	5% 1/8W
JW53	1-216-296-91	METAL GLAZE 0	5% 1/8W
JW54	1-216-296-91	METAL GLAZE 0	5% 1/8W
JW55	1-216-296-91	METAL GLAZE 0	5% 1/8W
JW56	1-216-296-91	METAL GLAZE 0	5% 1/8W
JW57	1-216-296-91	METAL GLAZE 0	5% 1/8W
JW58	1-216-296-91	METAL GLAZE 0	5% 1/8W
JW59	1-216-296-91	METAL GLAZE 0	5% 1/8W
JW60	1-216-296-91	METAL GLAZE 0	5% 1/8W
JW61	1-216-296-91	METAL GLAZE 0	5% 1/8W
JW62	1-216-296-91	METAL GLAZE 0	5% 1/8W
JW63	1-216-296-91	METAL GLAZE 0	5% 1/8W
		< COIL >	
L11	1-410-780-11	INDUCTOR	27mH
L21	1-410-780-11	INDUCTOR	27mH
		< TRANSISTOR >	
Q51	8-729-142-46	TRANSISTOR	2SC2001-LK
Q52	8-729-142-46	TRANSISTOR	2SC2001-LK
Q53	8-729-111-29	TRANSISTOR	2SD1616A-K
Q71	8-729-216-22	TRANSISTOR	2SA1162-G

# AUDIO

Ref.No.	Part No.	Description	Remark
< RESISTOR >			
R11	1-216-107-00	METAL CHIP	270K 5% 1/10W
R12	1-216-025-00	METAL CHIP	100 5% 1/10W
R13	1-216-100-00	METAL GLAZE	130K 5% 1/10W
R14	1-216-068-00	METAL CHIP	6.2K 5% 1/10W
R15	1-249-430-11	CARBON	12K 5% 1/4W
R21	1-216-107-00	METAL CHIP	270K 5% 1/10W
R22	1-216-025-00	METAL CHIP	100 5% 1/10W
R23	1-216-100-00	METAL GLAZE	130K 5% 1/10W
R24	1-216-068-00	METAL CHIP	6.2K 5% 1/10W
R25	1-249-430-11	CARBON	12K 5% 1/4W
R31	1-216-033-00	METAL CHIP	220 5% 1/10W
R32	1-216-033-00	METAL CHIP	220 5% 1/10W
R41	1-249-393-11	CARBON	10 5% 1/4W
R42	1-249-393-11	CARBON	10 5% 1/4W
R51	1-216-085-00	METAL CHIP	33K 5% 1/10W
R52	1-216-085-00	METAL CHIP	33K 5% 1/10W
R53	1-216-073-00	METAL CHIP	10K 5% 1/10W
R54	1-216-309-00	METAL CHIP	5.6 5% 1/10W
R55	1-216-309-00	METAL CHIP	5.6 5% 1/10W
R56	1-216-298-00	METAL CHIP	2.2 5% 1/10W
R71	1-216-082-00	METAL GLAZE	24K 5% 1/10W
R72	1-216-081-00	METAL CHIP	22K 5% 1/10W
R73	1-216-089-91	METAL GLAZE	47K 5% 1/10W
R74	1-216-089-91	METAL GLAZE	47K 5% 1/10W
< VARIABLE RESISTOR >			
RV11	1-241-761-11	RES, ADJ, CARBON 1K	
RV12	1-238-551-11	RES, ADJ, CARBON 220K	
RV21	1-241-761-11	RES, ADJ, CARBON 1K	
RV22	1-238-551-11	RES, ADJ, CARBON 220K	
RV71	1-241-630-11	RES, ADJ, CARBON 10K	
RV72	1-241-630-11	RES, ADJ, CARBON 10K	
< RELAY >			
RY31	1-515-913-11	RELAY	
< TRANSFORMER >			
T51	1-426-650-11	TRANSFORMER, BIAS OSCILLATION	

\*\*\*\*\*

Ref.No.	Part No.	Description	Remark
*	A-2006-890-A	AUDIO BOARD, COMPLETE (K315)	
*****			
< CAPACITOR >			
C11	1-163-133-00	CERAMIC CHIP	470PF 5% 50V
C12	1-136-157-00	FILM	0.022uF 5% 50V
C13	1-124-234-00	ELECT	22uF 20% 16V
C18	1-163-117-00	CERAMIC CHIP	100PF 5% 50V
C21	1-163-133-00	CERAMIC CHIP	470PF 5% 50V
C22	1-136-157-00	FILM	0.022uF 5% 50V
C23	1-124-234-00	ELECT	22uF 20% 16V
C28	1-163-117-00	CERAMIC CHIP	100PF 5% 50V
C31	1-124-234-00	ELECT	22uF 20% 16V
C32	1-124-234-00	ELECT	22uF 20% 16V
C33	1-124-234-00	ELECT	22uF 20% 16V
C51	1-164-182-11	CERAMIC CHIP	0.0033uF 10% 50V
C52	1-164-182-11	CERAMIC CHIP	0.0033uF 10% 50V
C53	1-163-020-00	CERAMIC CHIP	0.0082uF 10% 50V
C54	1-136-601-11	FILM	0.01uF 5% 630V
C56	1-164-505-11	CERAMIC CHIP	2.2uF 16V
C57	1-164-346-11	CERAMIC CHIP	1uF 16V
C71	1-164-346-11	CERAMIC CHIP	1uF 16V
C80	1-124-234-00	ELECT	22uF 20% 16V
C81	1-164-232-11	CERAMIC CHIP	0.01uF 50V
C82	1-136-157-00	FILM	0.022uF 5% 50V
C83	1-164-004-11	CERAMIC CHIP	0.1uF 10% 25V
C84	1-136-439-11	FILM	330PF 5% 630V
C85	1-136-433-11	FILM	100PF 5% 630V
C86	1-163-143-00	CERAMIC CHIP	0.0012uF 5% 50V
C87	1-136-273-91	FILM	75PF 5% 630V
C88	1-163-003-11	CERAMIC CHIP	330PF 10% 50V
C89	1-124-234-00	ELECT	22uF 20% 16V
C90	1-107-584-91	CERAMIC	4PF 0.25PF 500V
C91	1-164-232-11	CERAMIC CHIP	0.01uF 50V
C92	1-136-157-00	FILM	0.022uF 5% 50V
C93	1-164-004-11	CERAMIC CHIP	0.1uF 10% 25V
C94	1-136-439-11	FILM	330PF 5% 630V
C95	1-136-433-11	FILM	100PF 5% 630V
C96	1-163-143-00	CERAMIC CHIP	0.0012uF 5% 50V
C97	1-136-273-91	FILM	75PF 5% 630V
C98	1-163-003-11	CERAMIC CHIP	330PF 10% 50V
C99	1-164-005-11	CERAMIC CHIP	0.47uF 25V
< CONNECTOR >			
*CNP31	1-580-782-11	CONNECTOR, BOARD TO BOARD	
*CNP32	1-580-781-11	PIN, CONNECTOR (PC BOARD) 7P	
*CNP33	1-580-782-11	CONNECTOR, BOARD TO BOARD	
*CNP71	1-564-719-11	PIN, CONNECTOR (SMALL TYPE) 3P	
*CNP72	1-580-411-11	SOCKET, CONNECTOR 4P	

**AUDIO****AUDIO SYSTEM CONTROL****DISPLAY****HP****REC VOL****TRANSFORMER**

Ref.No.	Part No.	Description	Remark
< DIODE >			
D31	8-719-404-46	DIODE MA110	
< IC >			
IC31	8-759-106-02	IC UPC4570G2	
IC81	8-759-106-56	IC UPC1297CA	
< COIL >			
L81	1-410-780-11	INDUCTOR 27mH	
L91	1-410-780-11	INDUCTOR 27mH	
< TRANSISTOR >			
Q51	8-729-808-01	TRANSISTOR 2SD1622-S	
Q52	8-729-808-01	TRANSISTOR 2SD1622-S	
Q53	8-729-808-01	TRANSISTOR 2SD1622-S	
Q71	8-729-120-10	TRANSISTOR 2SA812-M5M6	
< RESISTOR >			
R11	1-216-107-00	METAL CHIP 270K 5% 1/10W	
R12	1-216-025-00	METAL CHIP 100 5% 1/10W	
R13	1-216-100-00	METAL GLAZE 130K 5% 1/10W	
R14	1-216-068-00	METAL CHIP 6.2K 5% 1/10W	
R21	1-216-107-00	METAL CHIP 270K 5% 1/10W	
R22	1-216-025-00	METAL CHIP 100 5% 1/10W	
R23	1-216-100-00	METAL GLAZE 130K 5% 1/10W	
R24	1-216-068-00	METAL CHIP 6.2K 5% 1/10W	
R31	1-216-033-00	METAL CHIP 220 5% 1/10W	
R32	1-216-033-00	METAL CHIP 220 5% 1/10W	
R33	1-216-065-00	METAL CHIP 4.7K 5% 1/10W	
R51	1-216-091-00	METAL CHIP 56K 5% 1/10W	
R52	1-216-091-00	METAL CHIP 56K 5% 1/10W	
R53	1-216-073-00	METAL CHIP 10K 5% 1/10W	
R54	1-216-309-00	METAL CHIP 5.6 5% 1/10W	
R55	1-216-309-00	METAL CHIP 5.6 5% 1/10W	
R57	1-216-298-00	METAL CHIP 2.2 5% 1/10W	
R71	1-216-082-00	METAL GLAZE 24K 5% 1/10W	
R72	1-216-081-00	METAL CHIP 22K 5% 1/10W	
R73	1-216-089-91	METAL GLAZE 47K 5% 1/10W	
R74	1-216-089-91	METAL GLAZE 47K 5% 1/10W	
R81	1-216-073-00	METAL CHIP 10K 5% 1/10W	
R82	1-216-085-00	METAL CHIP 33K 5% 1/10W	
R83	1-216-001-00	METAL CHIP 10 5% 1/10W	
R84	1-216-101-00	METAL CHIP 150K 5% 1/10W	
R85	1-216-075-00	METAL CHIP 12K 5% 1/10W	
R91	1-216-073-00	METAL CHIP 10K 5% 1/10W	
R92	1-216-085-00	METAL CHIP 33K 5% 1/10W	
R93	1-216-001-00	METAL CHIP 10 5% 1/10W	
R94	1-216-101-00	METAL CHIP 150K 5% 1/10W	
R95	1-216-075-00	METAL CHIP 12K 5% 1/10W	

Ref.No.	Part No.	Description	Remark
< VARIABLE RESISTOR >			
RV11	1-241-761-11	RES, ADJ, CARBON 1K	
RV21	1-241-761-11	RES, ADJ, CARBON 1K	
RV71	1-241-630-11	RES, ADJ, CARBON 10K	
RV72	1-241-630-11	RES, ADJ, CARBON 10K	
RV81	1-241-786-11	RES, ADJ, CARBON 22K	
RV91	1-241-786-11	RES, ADJ, CARBON 22K	
< RELAY >			
RY31	1-515-913-11	RELAY	
< TRANSFORMER >			
T51	1-433-383-11	TRANSFORMER, BIAS OSCILLATION	
T81	1-433-398-11	TRANSFORMER, BIAS OSCILLATOR	
T91	1-433-398-11	TRANSFORMER, BIAS OSCILLATOR	
< TEST PIN >			
*TP81	1-568-449-11	HOUSING, CONNECTOR(PC BOARD)3P	
*****			
*	A-2007-178-A	AUDIO SYSTEM CONTROL BOARD, COMPLETE (K215)	
*	A-2007-179-A	AUDIO SYSTEM CONTROL BOARD, COMPLETE (K315:E)	
*	A-2007-181-A	AUDIO SYSTEM CONTROL BOARD, COMPLETE (K315:AEP, G, AUS)	
*****			
DISPLAY BOARD			
*****			
HP BOARD			
*****			
REC VOL BOARD			
*****			
TRANSFORMER BOARD			
*****			
*	3-377-337-11	HOLDER (FL)	
< CAPACITOR >			
C101	1-136-157-00	FILM 0.022uF 5% 50V	
C102	1-124-927-11	ELECT 4.7uF 20% 100V	
C103	1-161-375-00	CERAMIC 0.0022uF 20% 50V	
C104	1-124-907-11	ELECT 10uF 20% 50V	
C105	1-136-165-00	FILM 0.1uF 5% 50V	
C106	1-136-163-00	FILM 0.068uF 5% 50V	
C107	1-124-916-11	ELECT 22uF 20% 63V	
C109	1-124-907-11	ELECT 10uF 20% 50V	
C110	1-124-927-11	ELECT 4.7uF 20% 100V	
C111	1-126-962-11	ELECT 3.3uF 20% 50V	
C112	1-124-902-00	ELECT 0.47uF 20% 50V	
C113	1-124-927-11	ELECT 4.7uF 20% 100V	

**AUDIO SYSTEM CONTROL**

**DISPLAY**

**HP**

**REC VOL**

**TRANSFORMER**

Ref.No.	Part No.	Description	Remark		
C131	1-124-927-11	ELECT	4.7uF	20%	100V (K315)
C132	1-126-962-11	ELECT	3.3uF	20%	50V
C201	1-136-157-00	FILM	0.022uF	5%	50V
C202	1-124-927-11	ELECT	4.7uF	20%	100V
C203	1-161-375-00	CERAMIC	0.0022uF	20%	50V
C204	1-124-907-11	ELECT	10uF	20%	50V
C205	1-136-165-00	FILM	0.1uF	5%	50V
C206	1-136-163-00	FILM	0.068uF	5%	50V
C207	1-124-916-11	ELECT	22uF	20%	63V
C209	1-124-907-11	ELECT	10uF	20%	50V
C210	1-124-927-11	ELECT	4.7uF	20%	100V
C211	1-126-962-11	ELECT	3.3uF	20%	50V
C212	1-124-902-00	ELECT	0.47uF	20%	50V
C213	1-124-927-11	ELECT	4.7uF	20%	100V
C231	1-124-927-11	ELECT	4.7uF	20%	100V (K315)
C232	1-126-962-11	ELECT	3.3uF	20%	50V
C501	1-124-360-00	ELECT	1000uF	20%	16V
C502	1-124-907-11	ELECT	10uF	20%	50V
C503	1-124-907-11	ELECT	10uF	20%	50V
C504	1-124-903-11	ELECT	1uF	20%	50V
C505	1-124-907-11	ELECT	10uF	20%	50V
C506	1-124-472-11	ELECT	470uF	20%	10V (K215)
C506	1-124-443-00	ELECT	100uF	20%	10V (K315)
C511	1-136-161-00	FILM	0.047uF	5%	50V (K315)
C512	1-136-164-00	FILM	0.082uF	5%	50V (K315)
C513	1-137-367-11	FILM	0.0033uF	5%	50V (K315)
C521	1-124-907-11	ELECT	10uF	20%	50V
C551	1-162-282-31	CERAMIC	100PF	10%	50V
C552	1-161-494-00	CERAMIC	0.022uF		25V
C553	1-162-217-31	CERAMIC	56PF	5%	50V
C554	1-124-925-11	ELECT	2.2uF	20%	100V
C555	1-124-925-11	ELECT	2.2uF	20%	100V
C571	1-124-916-11	ELECT	22uF	20%	63V
C572	1-126-916-11	ELECT	1000uF	20%	6.3V
C601	1-164-159-11	CERAMIC	0.1uF		50V
C602	1-162-288-31	CERAMIC	330PF	10%	50V
C701	1-124-563-11	ELECT	2200uF	20%	25V
C702	1-124-563-11	ELECT	2200uF	20%	25V
C703	1-124-477-11	ELECT	47uF	20%	25V
C704	1-124-473-11	ELECT	1000uF	20%	10V
C705	1-124-473-11	ELECT	1000uF	20%	10V
C706	1-124-472-11	ELECT	470uF	20%	10V
C707	1-124-907-11	ELECT	10uF	20%	50V
C708	1-124-903-11	ELECT	1uF	20%	50V
C709	1-124-122-11	ELECT	100uF	20%	50V
C710	1-124-477-11	ELECT	47uF	20%	25V
C711	1-164-159-11	CERAMIC	0.1uF		50V
C801	1-124-927-11	ELECT	4.7uF	20%	100V

Ref.No.	Part No.	Description	Remark		
C803	1-161-494-00	CERAMIC	0.022uF		25V
C804	1-161-494-00	CERAMIC	0.022uF		25V
C805	1-164-159-11	CERAMIC	0.1uF		50V
C806	1-124-907-11	ELECT	10uF	20%	50V
C807	1-124-472-11	ELECT	470uF	20%	10V
C808	1-161-494-00	CERAMIC	0.022uF		25V
C809	1-161-494-00	CERAMIC	0.022uF		25V
C810	1-162-282-31	CERAMIC	100PF	10%	50V
C811	1-164-159-11	CERAMIC	0.1uF		50V
C921	1-124-903-11	ELECT	1uF	20%	50V
< CONNECTOR >					
*CN501	1-691-916-11	CONNECTOR, BOARD TO BOARD			
*CN502	1-691-916-11	CONNECTOR, BOARD TO BOARD			
CN503	1-568-826-11	CONNECTOR, FFC/FPC 7P			
CN504	1-750-418-11	CONNECTOR, FFC/FPC 13P			
CN505	1-750-438-11	CONNECTOR, FFC/FPC 33P			
CN506	1-506-468-11	PIN, CONNECTOR 3P			
CN701	1-564-510-11	PLUG, CONNECTOR 7P			
*CN702	1-580-230-31	PIN, CONNECTOR (PC BOARD) 2P			
*CN703	1-573-565-11	PIN, CONNECTOR 5P (K315:E)			
< CONNECTOR >					
CNP504	1-750-418-11	CONNECTOR, FFC/FPC 13P			
CNP505	1-750-438-11	CONNECTOR, FFC/FPC 33P			
< DIODE >					
D131	8-719-987-63	DIODE	1N4148M		
D132	8-719-987-63	DIODE	1N4148M		
D231	8-719-987-63	DIODE	1N4148M		
D232	8-719-987-63	DIODE	1N4148M		
D511	8-719-987-63	DIODE	1N4148M	(K315)	
D512	8-719-987-63	DIODE	1N4148M	(K315)	
D551	8-719-987-63	DIODE	1N4148M		
D571	8-719-987-63	DIODE	1N4148M		
D701	8-719-024-99	DIODE	11ES2-NTA2B		
D702	8-719-024-99	DIODE	11ES2-NTA2B		
D703	8-719-024-99	DIODE	11ES2-NTA2B		
D704	8-719-024-99	DIODE	11ES2-NTA2B		
D705	8-719-987-63	DIODE	1N4148M		
D706	8-719-987-63	DIODE	1N4148M		
D707	8-719-024-99	DIODE	11ES2-NTA2B		
D708	8-719-933-33	DIODE	HZS6A1L		
D709	8-719-001-51	DIODE	UZL-11H1		
D710	8-719-000-60	DIODE	UZL-6M2		
D711	8-719-987-63	DIODE	1N4148M		
D712	8-719-987-63	DIODE	1N4148M		
D713	8-719-000-93	DIODE	UZL-7H1		
D714	8-719-987-63	DIODE	1N4148M		

## TRANSFORMER

Ref.No.	Part No.	Description	Remark	Ref.No.	Part No.	Description	Remark
D715	8-719-933-33	DIODE HZS6A1L		Q532	8-729-900-80	TRANSISTOR DTC114ES	
D801	8-719-933-33	DIODE HZS6A1L		Q551	8-729-119-76	TRANSISTOR 2SA1175-HFE	
D802	8-719-933-33	DIODE HZS6A1L		Q571	8-729-900-61	TRANSISTOR DTA114ES	
< FILTER >				Q572	8-729-900-61	TRANSISTOR DTA114ES	
FL901	1-517-173-11	INDICATOR TUBE, FLUORESCENT		Q573	8-729-900-65	TRANSISTOR DTA144ES (K315)	
< IC >				Q601	8-729-801-93	TRANSISTOR 2SD1387	
IC501	8-752-060-46	IC CXA1561S		Q701	8-729-141-83	TRANSISTOR 2SB1094-LK	
IC502	8-752-055-62	IC CXA1579P		Q702	8-729-209-15	TRANSISTOR 2SD2012	
IC503	8-759-145-58	IC UPC4558C (K315)		Q703	8-729-900-74	TRANSISTOR DTC143TS	
IC504	8-759-145-58	IC UPC4558C		Q704	8-729-141-83	TRANSISTOR 2SB1094-LK	
IC505	8-759-145-58	IC UPC4558C		Q705	8-729-119-78	TRANSISTOR 2SC2785-HFE	
IC506	8-759-140-53	IC UPD4053BC (K315)		Q706	8-729-900-74	TRANSISTOR DTC143TS	
IC507	8-759-145-58	IC UPC4558C (K315)		Q707	8-729-119-76	TRANSISTOR 2SA1175-HFE	
IC508	8-759-000-48	IC MC14052BCP		Q708	8-729-140-04	TRANSISTOR 2SB1116A-L	
IC509	8-759-916-14	IC SN74HC04AN (K315)		Q803	8-729-900-80	TRANSISTOR DTC114ES	
IC510	8-759-145-58	IC UPC4558C		Q805	8-729-119-76	TRANSISTOR 2SA1175-HFE	
IC511	8-759-145-58	IC UPC4558C		< RESISTOR >			
IC601	8-759-803-42	IC LA6500-FA		R101	1-247-838-00	CARBON 2K 5% 1/4W	
IC701	8-759-145-58	IC UPC4558C		R102	1-247-842-11	CARBON 3K 5% 1/4W	
IC801	8-752-842-10	IC CXP82316-014Q		R104	1-249-417-11	CARBON 1K 5% 1/4W	
IC802	8-759-165-82	IC PST600E-T		R105	1-249-423-11	CARBON 3.3K 5% 1/4W	
IC901	8-741-100-48	IC SBX1610-59		R106	1-247-887-00	CARBON 220K 5% 1/4W	
< JACK >				R107	1-249-428-11	CARBON 8.2K 5% 1/4W	
J501	1-565-258-11	JACK, PIN 4P (LINE)		R110	1-249-429-11	CARBON 10K 5% 1/4W	
J502	1-568-519-41	JACK, LARGE TYPE (HEADPHONES)		R111	1-249-423-11	CARBON 3.3K 5% 1/4W	
< FILTER >				R121	1-249-437-11	CARBON 47K 5% 1/4W	
LPF101	1-231-388-00	FILTER, LOW PASS		R122	1-249-421-11	CARBON 2.2K 5% 1/4W	
LPF201	1-231-388-00	FILTER, LOW PASS		R123	1-249-421-11	CARBON 2.2K 5% 1/4W	
< TRANSISTOR >				R124	1-249-437-11	CARBON 47K 5% 1/4W (K315)	
Q101	8-729-900-89	TRANSISTOR DTC144ES		R125	1-249-425-11	CARBON 4.7K 5% 1/4W (K315)	
Q102	8-729-900-80	TRANSISTOR DTC114ES		R131	1-249-425-11	CARBON 4.7K 5% 1/4W (K315)	
Q121	8-729-142-25	TRANSISTOR 2SD1020-HFE		R132	1-247-822-11	CARBON 430 5% 1/4W (K315)	
Q122	8-729-119-78	TRANSISTOR 2SC2785-HFE (K315)		R133	1-247-866-11	CARBON 30K 5% 1/4W (K315)	
Q201	8-729-900-89	TRANSISTOR DTC144ES		R134	1-247-866-11	CARBON 30K 5% 1/4W	
Q202	8-729-900-80	TRANSISTOR DTC114ES		R135	1-249-439-11	CARBON 68K 5% 1/4W	
Q221	8-729-142-25	TRANSISTOR 2SD1020-HFE		R136	1-249-410-11	CARBON 270 5% 1/4W	
Q222	8-729-119-78	TRANSISTOR 2SC2785-HFE (K315)		R141	1-249-432-11	CARBON 18K 5% 1/4W	
Q503	8-729-900-61	TRANSISTOR DTA114ES		R142	1-249-432-11	CARBON 18K 5% 1/4W	
Q504	8-729-900-80	TRANSISTOR DTC114ES		R143	1-249-421-11	CARBON 2.2K 5% 1/4W	
Q511	8-729-119-78	TRANSISTOR 2SC2785-HFE (K315)		R144	1-247-854-11	CARBON 9.1K 5% 1/4W	
Q512	8-729-900-74	TRANSISTOR DTC143TS (K315)		R145	1-249-409-11	CARBON 220 5% 1/4W	
Q521	8-729-900-80	TRANSISTOR DTC114ES		R151	1-249-433-11	CARBON 22K 5% 1/4W	
Q531	8-729-900-61	TRANSISTOR DTA114ES (K315)		R152	1-249-417-11	CARBON 1K 5% 1/4W	
				R153	1-249-441-11	CARBON 100K 5% 1/4W	
				R154	1-249-433-11	CARBON 22K 5% 1/4W	
				R161	1-249-429-11	CARBON 10K 5% 1/4W	
				R201	1-247-838-00	CARBON 2K 5% 1/4W	



**AUDIO SYSTEM CONTROL**

**DISPLAY**

**HP**

**REC VOL**

**TRANSFORMER**

Ref.No.	Part No.	Description	Remark		
R202	1-247-842-11	CARBON	3K	5%	1/4W
R204	1-249-417-11	CARBON	1K	5%	1/4W
R205	1-249-423-11	CARBON	3.3K	5%	1/4W
R206	1-247-887-00	CARBON	220K	5%	1/4W
R207	1-249-428-11	CARBON	8.2K	5%	1/4W
R210	1-249-429-11	CARBON	10K	5%	1/4W
R211	1-249-423-11	CARBON	3.3K	5%	1/4W
R221	1-249-437-11	CARBON	47K	5%	1/4W
R222	1-249-421-11	CARBON	2.2K	5%	1/4W
R223	1-249-421-11	CARBON	2.2K	5%	1/4W
R224	1-249-437-11	CARBON	47K	5%	1/4W (K315)
R225	1-249-425-11	CARBON	4.7K	5%	1/4W (K315)
R231	1-249-425-11	CARBON	4.7K	5%	1/4W (K315)
R232	1-247-822-11	CARBON	430	5%	1/4W (K315)
R233	1-247-866-11	CARBON	30K	5%	1/4W (K315)
R234	1-247-866-11	CARBON	30K	5%	1/4W
R235	1-249-439-11	CARBON	68K	5%	1/4W
R236	1-249-410-11	CARBON	270	5%	1/4W
R241	1-249-432-11	CARBON	18K	5%	1/4W
R242	1-249-432-11	CARBON	18K	5%	1/4W
R243	1-249-421-11	CARBON	2.2K	5%	1/4W
R244	1-247-854-11	CARBON	9.1K	5%	1/4W
R245	1-249-409-11	CARBON	220	5%	1/4W
R251	1-249-433-11	CARBON	22K	5%	1/4W
R252	1-249-417-11	CARBON	1K	5%	1/4W
R253	1-249-441-11	CARBON	100K	5%	1/4W
R254	1-249-433-11	CARBON	22K	5%	1/4W
R261	1-249-429-11	CARBON	10K	5%	1/4W
R502	1-215-452-00	METAL	20K	1%	1/6W
R503	1-249-422-11	CARBON	2.7K	5%	1/4W
R504	1-215-455-00	METAL	27K	1%	1/6W
R505	1-249-417-11	CARBON	1K	5%	1/4W
R511	1-249-429-11	CARBON	10K	5%	1/4W (K315)
R512	1-249-421-11	CARBON	2.2K	5%	1/4W (K315)
R513	1-249-441-11	CARBON	100K	5%	1/4W (K315)
R514	1-249-441-11	CARBON	100K	5%	1/4W (K315)
R515	1-249-436-11	CARBON	39K	5%	1/4W (K315)
R516	1-249-425-11	CARBON	4.7K	5%	1/4W (K315)
R517	1-249-433-11	CARBON	22K	5%	1/4W (K315)
R518	1-249-425-11	CARBON	4.7K	5%	1/4W (K315)
R521	1-249-426-11	CARBON	5.6K	5%	1/4W (K315)
R522	1-249-426-11	CARBON	5.6K	5%	1/4W (K315)
R523	1-247-858-11	CARBON	13K	5%	1/4W (K315)
R524	1-247-852-11	CARBON	7.5K	5%	1/4W (K315)
R525	1-247-854-11	CARBON	9.1K	5%	1/4W (K315)
R526	1-247-854-11	CARBON	9.1K	5%	1/4W (K315)
R527	1-249-426-11	CARBON	5.6K	5%	1/4W (K315)
R528	1-249-422-11	CARBON	2.7K	5%	1/4W (K315)
R529	1-249-429-11	CARBON	10K	5%	1/4W

Ref.No.	Part No.	Description	Remark		
R530	1-249-421-11	CARBON	2.2K	5%	1/4W
R531	1-249-427-11	CARBON	6.8K	5%	1/4W (K315)
R532	1-249-433-11	CARBON	22K	5%	1/4W (K315)
R535	1-249-419-11	CARBON	1.5K	5%	1/4W (K315)
R536	1-249-421-11	CARBON	2.2K	5%	1/4W (K315)
R537	1-247-866-11	CARBON	30K	5%	1/4W (K315)
R538	1-247-852-11	CARBON	7.5K	5%	1/4W (K315)
R539	1-249-431-11	CARBON	15K	5%	1/4W (K315)
R540	1-247-874-11	CARBON	62K	5%	1/4W (K315)
R541	1-249-429-11	CARBON	10K	5%	1/4W (K315)
R542	1-249-429-11	CARBON	10K	5%	1/4W (K315)
R543	1-249-429-11	CARBON	10K	5%	1/4W (K315)
R544	1-249-429-11	CARBON	10K	5%	1/4W (K315)
R553	1-249-437-11	CARBON	47K	5%	1/4W
R555	1-249-427-11	CARBON	6.8K	5%	1/4W
R556	1-249-423-11	CARBON	3.3K	5%	1/4W
R557	1-249-441-11	CARBON	100K	5%	1/4W
R558	1-249-429-11	CARBON	10K	5%	1/4W
R559	1-249-441-11	CARBON	100K	5%	1/4W
R560	1-249-417-11	CARBON	1K	5%	1/4W
R561	1-249-432-11	CARBON	18K	5%	1/4W
R562	1-249-436-11	CARBON	39K	5%	1/4W
R563	1-247-848-11	CARBON	5.1K	5%	1/4W (K215)
R564	1-247-834-11	CARBON	1.3K	5%	1/4W (K215)
R565	1-249-430-11	CARBON	12K	5%	1/4W (K215)
R567	1-249-433-11	CARBON	22K	5%	1/4W (K215)
R571	1-249-403-11	CARBON	68	5%	1/4W
R572	1-249-429-11	CARBON	10K	5%	1/4W
R573	1-249-429-11	CARBON	10K	5%	1/4W
R574	1-249-435-11	CARBON	33K	5%	1/4W (K315)
R575	1-247-807-31	CARBON	100	5%	1/4W
R601	1-249-419-11	CARBON	1.5K	5%	1/4W
R602	1-249-429-11	CARBON	10K	5%	1/4W
R603	1-247-807-31	CARBON	100	5%	1/4W
R604	1-249-433-11	CARBON	22K	5%	1/4W
R605	1-249-433-11	CARBON	22K	5%	1/4W
R606	1-249-430-11	CARBON	12K	5%	1/4W
R607	1-249-433-11	CARBON	22K	5%	1/4W
R608	1-247-862-11	CARBON	20K	5%	1/4W
R609	1-249-429-11	CARBON	10K	5%	1/4W
R701	1-249-425-11	CARBON	4.7K	5%	1/4W
R702	1-249-419-11	CARBON	1.5K	5%	1/4W
R703	1-249-418-11	CARBON	1.2K	5%	1/4W
R704	1-249-427-11	CARBON	6.8K	5%	1/4W
R705	1-249-419-11	CARBON	1.5K	5%	1/4W
R706	1-249-419-11	CARBON	1.5K	5%	1/4W
R707	1-249-429-11	CARBON	10K	5%	1/4W
R708	1-249-425-11	CARBON	4.7K	5%	1/4W

# AUDIO SYSTEM CONTROL

# DISPLAY

# HP

# REC VOL

## TRANSFORMER

## LEAF SW

Ref.No.	Part No.	Description	Remark		
R709	1-249-409-11	CARBON	220	5%	1/4W
R710	1-249-417-11	CARBON	1K	5%	1/4W
R711	1-249-427-11	CARBON	6.8K	5%	1/4W
R712	1-249-427-11	CARBON	6.8K	5%	1/4W
R713	1-249-429-11	CARBON	10K	5%	1/4W
R714	1-249-425-11	CARBON	4.7K	5%	1/4W
R715	1-249-421-11	CARBON	2.2K	5%	1/4W
R716	1-249-437-11	CARBON	47K	5%	1/4W
R717	1-249-429-11	CARBON	10K	5%	1/4W
R718	1-247-870-11	CARBON	43K	5%	1/4W
R719	1-249-429-11	CARBON	10K	5%	1/4W
R723	1-249-417-11	CARBON	1K	5%	1/4W
R801	1-249-417-11	CARBON	1K	5%	1/4W
R802	1-249-441-11	CARBON	100K	5%	1/4W
R805	1-249-434-11	CARBON	27K	5%	1/4W
R806	1-249-434-11	CARBON	27K	5%	1/4W (K315)
R807	1-249-434-11	CARBON	27K	5%	1/4W (K315)
R808	1-249-434-11	CARBON	27K	5%	1/4W (K315)
R809	1-249-434-11	CARBON	27K	5%	1/4W (K315)
R810	1-247-807-31	CARBON	100	5%	1/4W
R811	1-247-807-31	CARBON	100	5%	1/4W
R812	1-247-807-31	CARBON	100	5%	1/4W
R813	1-247-807-31	CARBON	100	5%	1/4W
R814	1-247-807-31	CARBON	100	5%	1/4W
R815	1-247-807-31	CARBON	100	5%	1/4W
R816	1-247-807-31	CARBON	100	5%	1/4W
R817	1-249-435-11	CARBON	33K	5%	1/4W
R818	1-249-435-11	CARBON	33K	5%	1/4W
R819	1-249-435-11	CARBON	33K	5%	1/4W
R820	1-247-807-31	CARBON	100	5%	1/4W
R821	1-249-435-11	CARBON	33K	5%	1/4W
R822	1-249-429-11	CARBON	10K	5%	1/4W
R823	1-249-435-11	CARBON	33K	5%	1/4W
R824	1-249-421-11	CARBON	2.2K	5%	1/4W
R825	1-249-441-11	CARBON	100K	5%	1/4W
R826	1-249-421-11	CARBON	2.2K	5%	1/4W
R827	1-249-422-11	CARBON	2.7K	5%	1/4W
R828	1-249-422-11	CARBON	2.7K	5%	1/4W
R829	1-249-422-11	CARBON	2.7K	5%	1/4W
R830	1-249-435-11	CARBON	33K	5%	1/4W
R901	1-249-420-11	CARBON	1.8K	5%	1/4W
R903	1-247-854-11	CARBON	9.1K	5%	1/4W
R904	1-249-429-11	CARBON	10K	5%	1/4W
R905	1-249-435-11	CARBON	33K	5%	1/4W
R906	1-249-420-11	CARBON	1.8K	5%	1/4W
R907	1-249-423-11	CARBON	3.3K	5%	1/4W
R908	1-249-426-11	CARBON	5.6K	5%	1/4W
R911	1-249-429-11	CARBON	10K	5%	1/4W

Ref.No.	Part No.	Description	Remark		
R912	1-249-429-11	CARBON	10K	5%	1/4W
R913	1-249-429-11	CARBON	10K	5%	1/4W
R921	1-247-850-11	CARBON	6.2K	5%	1/4W
R922	1-247-862-11	CARBON	20K	5%	1/4W
R923	1-249-428-11	CARBON	8.2K	5%	1/4W
R924	1-249-425-11	CARBON	4.7K	5%	1/4W
R925	1-249-437-11	CARBON	47K	5%	1/4W

### < VARIABLE RESISTOR >

RV111	1-241-630-11	RES, ADJ, CARBON 10K
RV211	1-241-630-11	RES, ADJ, CARBON 10K
RV901	1-223-604-11	RES, VAR, CARBON 10K/10K (REC LEVEL)
RV902	1-223-605-11	RES, VAR, CARBON 20K/20K (BALANCE)

### < SWITCH >

S901	1-554-303-21	SWITCH, TACTILE (PAUSE ■■)
S903	1-554-303-21	SWITCH, TACTILE (>)
S905	1-554-303-21	SWITCH, TACTILE (REC MUTE ⊙)
S906	1-554-303-21	SWITCH, TACTILE (RESET)
S907	1-554-303-21	SWITCH, TACTILE (MEMORY)
S908	1-554-303-21	SWITCH, TACTILE (■)
S909	1-554-303-21	SWITCH, TACTILE (◀)
S910	1-554-303-21	SWITCH, TACTILE (▶▶)
S911	1-554-303-21	SWITCH, TACTILE (REC ●)
S913	1-692-409-11	SWITCH, PUSH (1 KEY) (POWER)
S921	1-554-303-21	SWITCH, TACTILE (AUTO CAL) (K315)
S922	1-692-408-11	SWITCH, ROTARY (DOLBY NR)
S923	1-554-118-00	SWITCH, PUSH (1 KEY) (MPX FILTER)

### < TRANSFORMER >

△T901	1-426-651-11	TRANSFORMER, POWER (TC-K215/TC-K315:AEP, G, AUS, EE)
△T901	1-426-652-11	TRANSFORMER, POWER (TC-K315:E)

### < TEST PIN >

* TP801	1-564-505-11	PLUG, CONNECTOR 2P
---------	--------------	--------------------

### < VIBRATOR >

X801	1-579-175-11	VIBRATOR, CERAMIC (10MHz)
------	--------------	---------------------------

\*\*\*\*\*

* 1-638-020-11	LEAF SW BOARD
----------------	---------------

\*\*\*\*\*

### < CONNECTOR >

* CNP81	1-568-850-11	SOCKET, CONNECTOR 7P
---------	--------------	----------------------

The components identified by mark △ or dotted line with mark △ are critical for safety. Replace only with part number specified.

**LEAF SW**

Ref.No.	Part No.	Description	Remark
		< IC >	
IC81	8-749-924-10	IC PHOTO REFLECTOR NJL5165K-B(H1)	
		< RESISTOR >	
R81	1-249-414-11	CARBON 560 5% 1/4W	
R83	1-247-834-11	CARBON 1.3K 5% 1/4W	
R84	1-249-417-11	CARBON 1K 5% 1/4W	
R85	1-249-408-11	CARBON 180 5% 1/4W	
		< SWITCH >	
S81	1-571-958-11	SWITCH, PUSH (1 KEY) (STOP)	
S82	1-571-281-21	SWITCH, LEAF (70uS)	
S83	1-571-281-21	SWITCH, LEAF (METAL)	
S84	1-571-281-21	SWITCH, LEAF (REC-A)	
S86	1-571-281-21	SWITCH, LEAF (HALF)	

\*\*\*\*\*

MISCELLANEOUS  
\*\*\*\*\*

△12	1-569-007-11	ADAPTER, CONVERSION 2P (TC-K315:E)
63	1-751-736-11	WIRE (FLAT TYPE) (33 CORE)
67	1-696-965-11	WIRE (FLAT TYPE) (7 CORE)
72	1-534-517-00	WIRE (FLAT TYPE) (13 CORE)
103	1-638-983-11	MOTOR FLEXIBLE BOARD

△CNP901	1-575-651-21	CORD, POWER (TC-K315:AEP, G, EE)
△CNP901	1-696-027-11	CORD, POWER (TC-K315:E)
△CNP901	1-696-586-11	CORD, POWER (TC-K215)
△CNP901	1-696-845-11	CORD, POWER (TC-K315:AUS)
HE901	1-543-673-11	HEAD, MAGNETIC (ERASE)

HRP901	1-543-919-11	HEAD, MAGNETIC (RECORD/PLAYBACK)
M901	X-3363-501-1	MOTOR ASSY, REEL
M902	X-3365-377-1	MOTOR ASSY, CAPSTAN
△S701	1-570-046-21	SWITCH, VOLTAGE CHANGE (TC-K315:E)

\*\*\*\*\*

ACCESSORIES & PACKING MATERIALS  
\*\*\*\*\*

	1-551-734-11	CORD, CONNECTION
	3-758-577-11	MANUAL, INSTRUCTION (ENGLISH, FRENCH, SPANISH) (TC-K315:AEP, E)
	3-758-577-41	MANUAL, INSTRUCTION (GERMAN, DUTCH, SWEDISH, ITALIAN) (TC-K315:AEP)
	3-758-577-51	MANUAL, INSTRUCTION (GERMAN) (TC-K315:G)
	3-758-577-61	MANUAL, INSTRUCTION (ENGLISH) (TC-K215/TC-K315:AUS, EE)
*	3-907-887-01	CUSHION
*	3-912-543-21	INDIVIDUAL CARTON (TC-K315:AUS)
*	3-912-543-31	INDIVIDUAL CARTON (TC-K315:AEP, G, E, EE)
*	3-912-543-41	INDIVIDUAL CARTON (TC-K215)

Ref.No.	Part No.	Description	Remark
		***** <b>HARDWARE LIST</b> *****	
#1	7-682-548-09	SCREW +BVTT 3X8 (S)	
#2	7-685-646-79	SCREW +BVTP 3X8 TYPE2 N-S (TC-K315:E)	
#3	7-621-849-00	SCREW (BV/RING)	
#4	7-685-134-19	SCREW (+ PTPWH) (2.6X8)	
#5	7-621-773-95	SCREW +BVTT 2.6X6 (S)	
#6	7-621-772-58	SCREW (+B2X10)	
#7	7-627-556-08	SCREW +P 2.6X2.8	
#8	7-621-775-00	SCREW +B 2.6X3	

The components identified by mark △ or dotted line with mark △ are critical for safety. Replace only with part number specified.

# TC-K215/K315

## SONY. SERVICE MANUAL

*AEP Model*  
TC-K215/K315

*UK Model*  
TC-K215

*E Model*

*Australian Model*  
TC-K315

## SUPPLEMENT-1

File this Supplement with the service manual.

**Subject : TC-K215 (AEP Model),  
TC-K215 (German Model) Addition**

- TC-K215 (AEP model) and TC-K215 (German model) are similar to the earlier TC-K215 (UK model).
- Refer to TC-K215 (UK model) service manual for information not contained this service manual.

Page	TC-K215 (UK Model)	TC-K215 (AEP Model) TC-K215 (German Model)																		
28	<table><thead><tr><th>Ref. No.</th><th>Part No.</th><th>Description</th></tr></thead><tbody><tr><td>△ CNP901</td><td>1-696-586-11</td><td>CORD, POWER</td></tr><tr><td>* 8</td><td>3-910-526-31</td><td>PANEL, BACK</td></tr></tbody></table>	Ref. No.	Part No.	Description	△ CNP901	1-696-586-11	CORD, POWER	* 8	3-910-526-31	PANEL, BACK	<table><thead><tr><th>Ref. No.</th><th>Part No.</th><th>Description</th></tr></thead><tbody><tr><td>△ CNP901</td><td>1-575-651-21</td><td>CORD, POWER</td></tr><tr><td>* 8</td><td>3-910-526-41</td><td>PANEL, BACK</td></tr></tbody></table>	Ref. No.	Part No.	Description	△ CNP901	1-575-651-21	CORD, POWER	* 8	3-910-526-41	PANEL, BACK
Ref. No.	Part No.	Description																		
△ CNP901	1-696-586-11	CORD, POWER																		
* 8	3-910-526-31	PANEL, BACK																		
Ref. No.	Part No.	Description																		
△ CNP901	1-575-651-21	CORD, POWER																		
* 8	3-910-526-41	PANEL, BACK																		
39	<table><tbody><tr><td>3-758-577-61</td><td>MANUAL, INSTRUCTION</td></tr></tbody></table>	3-758-577-61	MANUAL, INSTRUCTION	<table><tbody><tr><td>3-758-577-12</td><td>MANUAL, INSTRUCTION (ENGLISH, FRENCH, SPANISH, PORTOGUESE) (AEP Model)</td></tr><tr><td>3-758-577-42</td><td>MANUAL, INSTRUCTION (GERMAN, DUTCH, SWEDISH, ITALIAN) (AEP Model)</td></tr><tr><td>3-758-577-52</td><td>MANUAL, INSTRUCTION (German) (German Model)</td></tr></tbody></table>	3-758-577-12	MANUAL, INSTRUCTION (ENGLISH, FRENCH, SPANISH, PORTOGUESE) (AEP Model)	3-758-577-42	MANUAL, INSTRUCTION (GERMAN, DUTCH, SWEDISH, ITALIAN) (AEP Model)	3-758-577-52	MANUAL, INSTRUCTION (German) (German Model)										
3-758-577-61	MANUAL, INSTRUCTION																			
3-758-577-12	MANUAL, INSTRUCTION (ENGLISH, FRENCH, SPANISH, PORTOGUESE) (AEP Model)																			
3-758-577-42	MANUAL, INSTRUCTION (GERMAN, DUTCH, SWEDISH, ITALIAN) (AEP Model)																			
3-758-577-52	MANUAL, INSTRUCTION (German) (German Model)																			

The components identified by mark △ or dotted line with mark △ are critical for safety.  
Replace only with part number specified.