

TC-K222ESA/K890ES

SERVICE MANUAL

US Model
Canadian Model
Germany Model
TC-K890ES

E Model
TC-K222ESA/K890ES



Photo : TC-K890 ES

Dolby noise reduction and HX Pro headroom extension manufactured under license from Dolby Laboratories Licensing Corporation. HX Pro originated by Bang & Olufsen. "DOLBY", the double-D symbol  and "HX PRO" are trademarks of Dolby Laboratories Licensing Corporation.

SPECIFICATIONS

Recording system	4-track 2-channel stereo
Fast winding time	Approx. 90 sec. (with Sony C-60 cassette)
Bias	AC bias
Heads	Erasing head × 1 (S&F head) Recording head × 1 (LA head) Playback head × 1 (LA head)
Motors	Capstan motor × 1 (direct - drive linear torque BSL motor) Reel motor × 1 (DC motor)
Wow and flutter	± 0.04% W.Peak (IEC) 0.024% W.RMS (NAB) ± 0.065% W.Peak (DIN)
Signal-to-noise ratio (at peak level)	

Cassette (Dolby NR OFF)	Type IV (Sony Metal-S/Select)	Type II (Sony UX-S)	Type I (Sony HF-S)
	61 dB	59 dB	57 dB

Measured at peak level weighted without NR. The S/N is improved by about 15 dB at 500 Hz and by about 20 dB about 1 kHz with Dolby-C NR on, and by 5 dB at 1 kHz and by 10 dB about 5 kHz with Dolby-B NR on.

Harmonic distortion	0.4% (with Sony Type I, 160 nWb/m, 315 Hz, 3rd H.D.) 1.3% (with Sony Type IV, 250 nWb/m, 315 Hz, 3rd H.D.)
---------------------	---

Frequency response (DOLBY NR OFF)

Type IV cassette (Sony Metal-S/Select)	20 - 22,000 Hz (±3 dB, IEC) 20 - 16,000 Hz [±3 dB, (-4 dB recording)]
Type II cassette (Sony UX-S)	20 - 20,000 Hz (±3 dB, IEC)
Type I cassette (Sony HF-S)	20 - 17,000 Hz (±3 dB, IEC)

Inputs

Line inputs (phono jacks)	Sensitivity	0.16 V
	Input impedance	47 k ohms
CD DIRECT INPUT	Input impedance	47 k ohms

Model Name Using Similar Mechanism	TC-K222ESG
Tape Transport Mechanism Type	TCM-200D10

Outputs

Line outputs (phono jacks)	Rated output level	0.5 V at a load impedance of 47 k ohms
	Load impedance	Over 10 k ohms
Headphones (stereo phone jack)	Output level	0 - 3 mW at a load impedance of 32 ohms

General

Power requirements

US, Canadian model:
120 V AC, 60Hz
Germany model:
220 - 230 V AC (or 240 V AC adjustable by Sony personal),
50/60Hz

E model:
120, 220 or 240 V AC adjustable,
50/60Hz

Power consumption

23 W

Dimensions

Approx. 470 × 135 × 350 mm (w/h/d)
(18⁵/₈ × 5³/₈ × 13⁷/₈ inches)
including projecting parts and controls
Approx. 8.1 kg (17 lbs 14 oz)

Weight

Supplied accessories

Audio connecting cords (2)
Screws (4)
Wireless remote commander RM-J701 (1)*
Sony SUM-3 (NS) batteries (2)*

*Not supplied with model for Canada and European countries.

Design and specifications are subject to change without notice.

Note

This appliance conforms with EEC Directive 87/308/EEC regarding interference suppression.

STEREO CASSETTE DECK
SONY[®]

TC-K222ESA is successor model for TC-K222ESL.

TC-K890ES is successor model for TC-K870ES.

This service manual described only the difference for these new models. Please refer TC-K222ESL/K870ES service manual (9-956-281-11) for detail informations.

Notice of main change

1. The circuit description and electrical adjustment is difference due to change of output levels.
2. Cabinet and cabinet appearance.

SCHEMATIC DIAGRAM DIFFERENCE DESCRIPTION

Ref. No.	TC-K222ESL Description	TC-K222ESA/ K890ES Description
R118/ 218	CARBON 5.1K 5% 1/4W	CARBON 3.3K 5% 1/4W
R119/ 219	CARBON 2.7K 5% 1/4W	CARBON 3.3K 5% 1/4W
R137/ 237	CARBON 9.1K 5% 1/4W	CARBON 6.8K 5% 1/4W
R310/ 410	CARBON 430 5% 1/4W	CARBON 750 5% 1/4W
R312/ 412	CARBON 2.7K 5% 1/4W	CARBON 3.3K 5% 1/4W
R313/ 413	CARBON 5.1K 5% 1/4W	CARBON 3.3K 5% 1/4W
RV102/ 202	ADJ, CARBON 47K (CAL METER)	ADJ, CARBON 22K (CAL METER)

SECTION 1 DIAGRAMS

SCHEMATIC DIAGRAM

 : Difference position

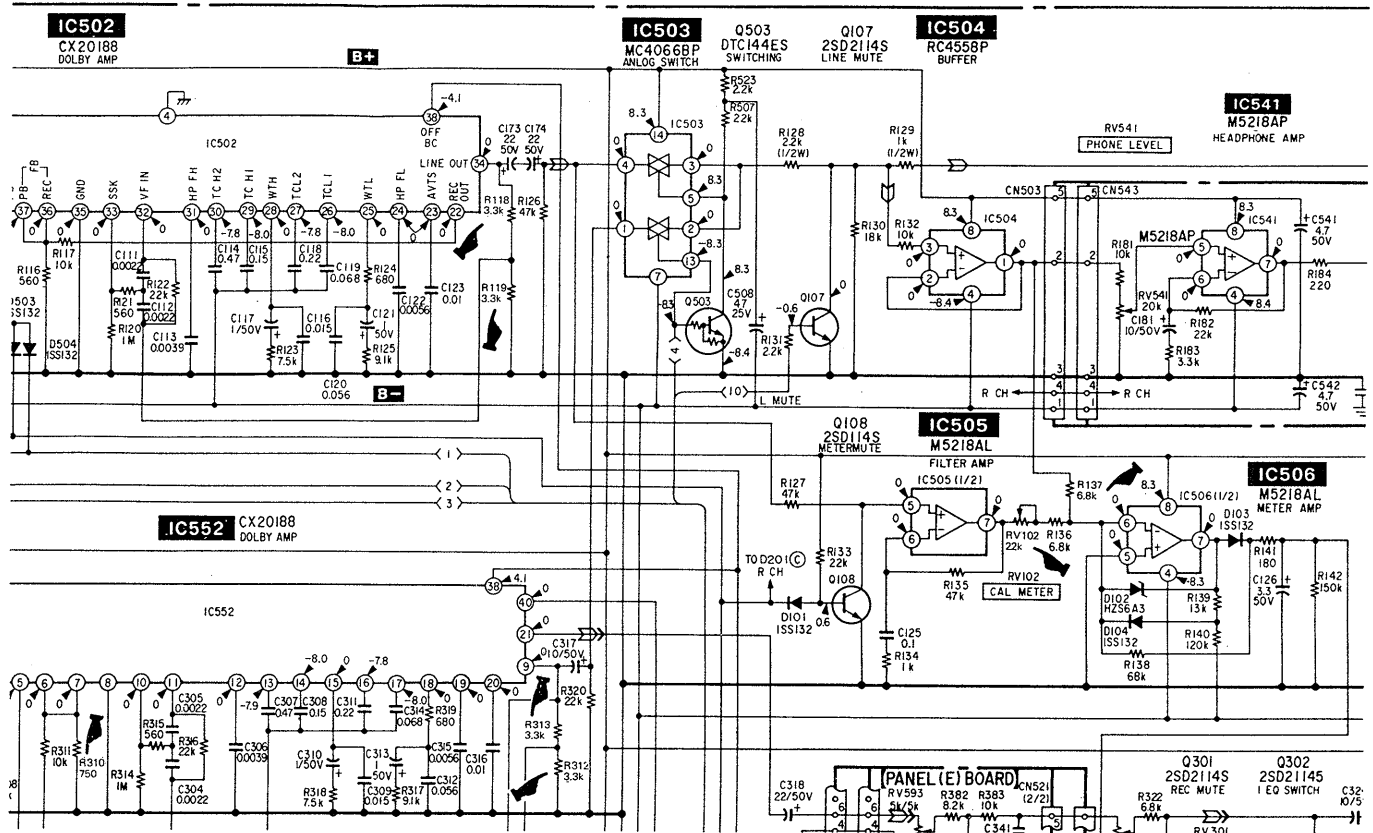

SECTION 2 ELECTRICAL ADJUSTMENTS

• Refer to page 6 for Adjustment Location.

1. Adjust the following in the order of listing. (Adjust the recording system after completion of adjusting the playback system, in general.)
2. Adjustments and measurements should be performed for each channel unless otherwise noted.
3. For simultaneous recording/playback, input a signal into the line and set the equipment to recording state to change the monitor to the tape, immediately playback the recorded signal and issue it from the line output.

• **Switch position**

DOLBY NR OFF
 MPX FILTER OFF
 TIMER OFF
 MONITOR TAPE
 HX PRO OFF
 CALIBRATION OFF
 CD DIRECT OFF
 BIAS CENTER CLICK
 REC LEVEL CENTER CLICK
 BALANCE CENTER CLICK

• **Specified recording position**

Adjust knobs REC LEVEL (RV591) and BALANCE (RV592) so that the following specified input/output signal level are obtained.

Recording state

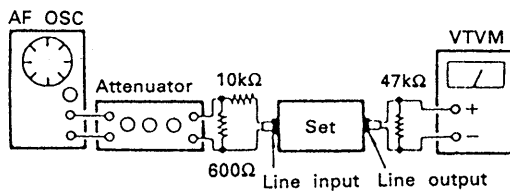

Specified input level

Input terminal	LINE IN
Signal source impedance	10kΩ
Input signal level	0.25V (-10dB)

Specified output level

Output terminal	LINE OUT
Load impedance	47kΩ
Output signal level	0.44V (-5dB)

Torque Adjustment

1. Set the torque measuring tape CQ-102C and set the equipment to playback state. Adjust RV801 so that the torque meter indicates 40 ± 3 g.cm.
2. After the completion of the adjustments, measure back tension and FF/REW torques and check that the following specifications are satisfied.

Torque	Torque meter	Meter reading
FWD	CQ-102C	37 - 43g·cm
FWD back tension	CQ-102C	8 - 10.5g·cm
FF/REW	CQ-201B	70 - 120g·cm

Tape Speeds/Wow Checking

Procedure:

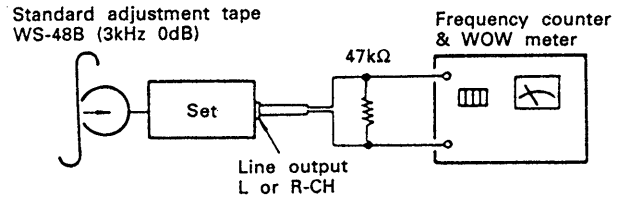

1. Playback the top section of the standard tape and measure its output frequency and WOW value.
2. Turn the standard tape upside down, measure the same values and check differences between both measured values. (Difference between the top and the end of the tape)

Adjustable limits:

TAPE SPEED deviation : 2,990 - 3,010 Hz or less
 TAPE SPEED variation width : 2,990 - 3,010 Hz or less
 WOW (WRMS) : 0.04% or less

MPX Filter Checking

Conditions:

DOLBY NR switch : OFF
 MPX FILTER switch : OFF

Procedure:

1. Mode: Stop state

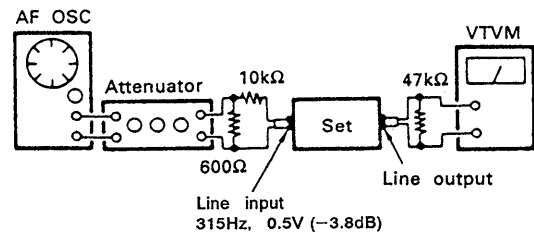

2. Apply the signal of 315Hz, 0.5V (-3.8dB) and set REC LEVEL and BALANCE so that the line output level becomes 0.5V (-3.8dB).
3. Apply the signal of 19kHz, 0.5V (-3.8dB) and measure the line output level.

Adjustable limits:

DOLBY NR switch: B or C
 MPX FILTER switch: Line output level upon ON
 315Hz: Within 0.45 to 0.56V (within -2.8 to -4.8dB)
 19kHz: 0.015V (-33.8dB) or less

Record/Playback Heads Vertical Adjustment

Procedure:

1. Mode: Playback

Standard adjustment tape
P-4-A100
(10kHz, -10dB)

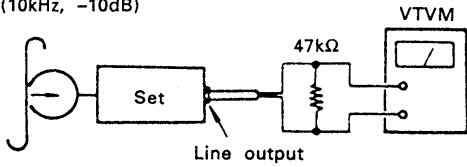

2. Adjust the adjustment screws so that L-CH and R-CH outputs become maximum. If the maximum output points of L-CH and R-CH do not coincide, adjust the screws so that the outputs agree with each other within 1dB from the maximum output value in each channel.

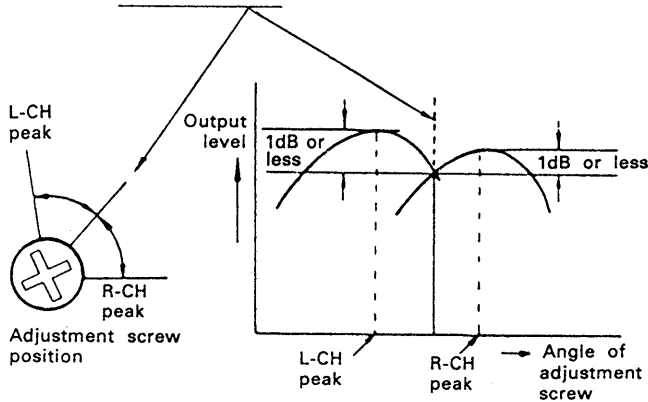

3. Checking of phases

- Playback state -

Standard adjustment tape
P-4-A100
(10kHz, -10dB)

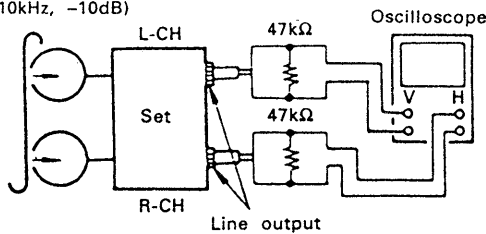

4. Check that the difference between L-CH and R-CH phases is in the same phase - 90°.

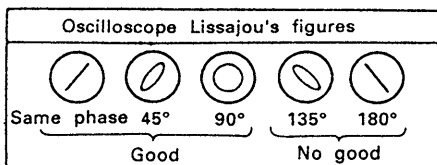

Adjustment Location:

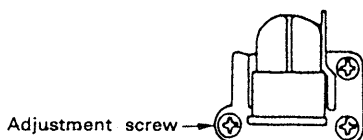

Playback Level Adjustment

Procedure:

1. Playback state

Standard adjustment tape
P-4-L300
(315Hz, 0dB)

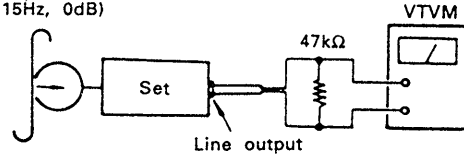

Adjust RV101 (L-CH) and RV201 (R-CH) to satisfy the following specifications.

Adjustable limits:

Line output level: 0.30 to 0.33V

(-7.2 to -8.2dB)

Level difference between channels: 0.5dB or less Check that, by repeating playback and stop, the line output level does not change.

Erase Current Adjustment

Procedure:

1. Mode: record

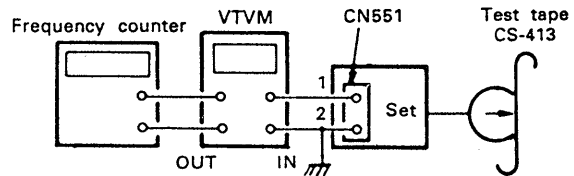

2. Adjust RV553 so that VTVM indicates 110mA (erase current 110mA).
3. Check oscillation frequency at that time.

Adjustable limits:

Erase current: 110 ± 0 mA

Oscillation frequency: 160 ± 6kHz

Bias Consumption Current Adjustment

Precautions:

Be sure to adjust bias consumption currents before adjusting recording bias. After completion of adjusting bias consumption currents, again adjust recording bias.

Condition:

HX PRO switch: ON

Procedure:

1. Set the semi-fixed resistances RV303 (L-CH) and RV403 (R-CH) for the adjustment of recording bias and RV554 at a mechanical center and set the equipment to recording state without signals.
2. Adjust T301 (R-CH) and T401 (L-CH) so that the digital voltmeter indicates a minimum value.

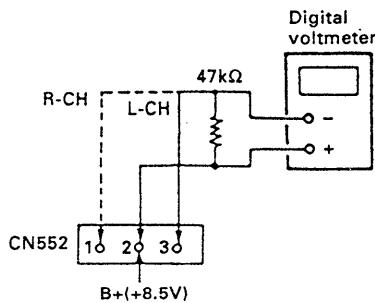

Adjustable limits:

120mV or less
(When measured using CS-413 after completion of adjusting the bias)

Bias and Recording Level (HX PRO ON) Adjustment

Conditions:

REC LEVEL knob: Specified recording position (see Page 3)
HX PRO switch: ON

Procedure:

1. Simultaneous record/playback state

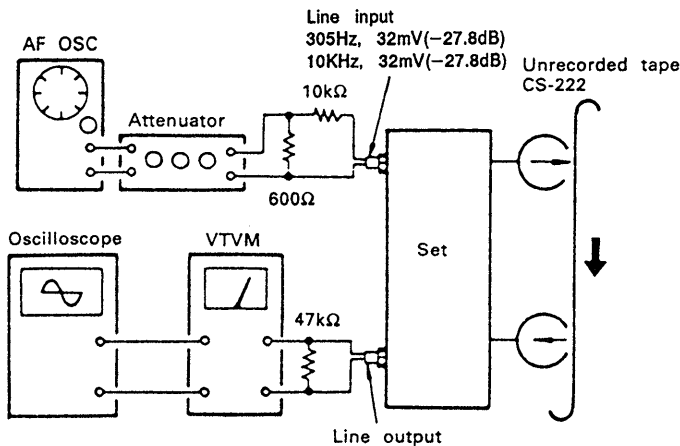

2. In order that the minimum output becomes the specified output level:
 - (1) Adjust RV303 (R-CH) and RV403 (L-CH).
.....Bias adjustment
 - (2) Adjust RV301 (R-CH) and RV403 (L-CH).
.....Recording level adjustment

Adjustable limits:

- (1) Difference of 10kHz level from 315Hz level: $\pm 0.3\text{dB}$ $\pm 3\text{dB}$
- (2) Level of 315Hz: -27.5dB to -28.1dB

Bias Adjustment (HX PRO OFF)

Conditions:

REC LEVEL knob: Specified recording position (see Page 3)
HX PRO switch: OFF

Procedure:

1. Simultaneous record/playback state

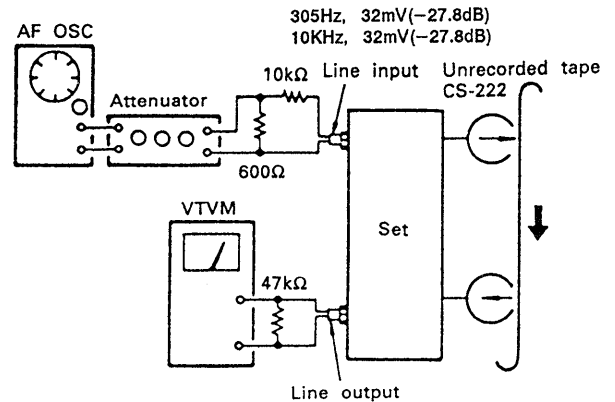

2. Adjust RV302 (L-CH) and RV402 (R-CH) so that the difference between playback outputs of 10kHz and 315Hz becomes $0.2 \pm 0.3\text{dB}$.

METAL bias Adjustment

Conditions:

REC LEVEL knob: Specified recording position (see page 3)
HX PRO switch: OFF

Procedure:

1. Simultaneous record/playback state

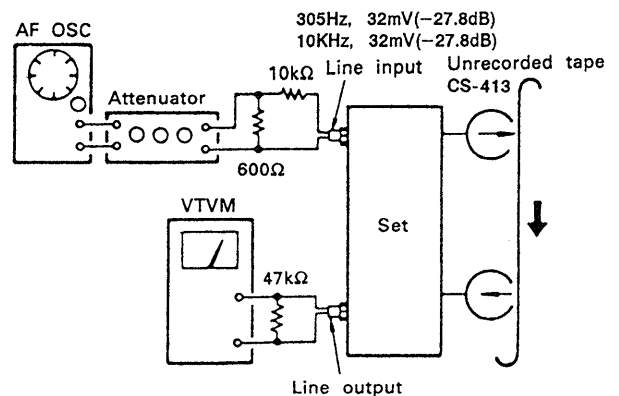

2. Adjust RV554 so that the difference of the playback output of 10kHz R-CH from the playback output of 315Hz becomes $\pm 0.3\text{dB}$.

CALIBRATION and Level Meter Adjustment

Condition:

CALIBRATION switch: ON

Procedure (oscillation output level):

1. Recording state (no line input signals)

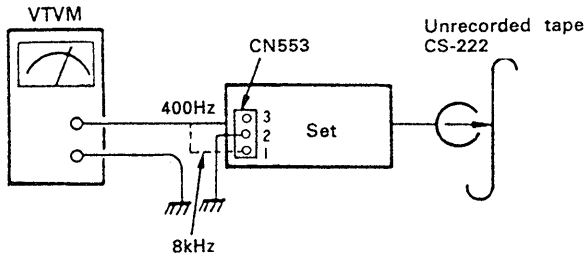

2. Adjust RV551 so that the level of the 400Hz check point becomes 9.5dB - 10.5dB.
3. Adjust RV552 so that the level of the 8kHz check point becomes 9.5dB - 10.5dB.

Procedure (level meter adjustments):

1. Recording state (no line input signals)
2. Set RV202 rather high and gradually decrease the level. Set the knob at a point where the level (a) 1 point higher than 0dB of the LOW FREQ segment (in the lower line) in the CAL level meter goes out.
3. Adjust RV102 so that HIGH FREQ segments (in the upper line) of the CAL level meter light up completely up to the 0dB position.

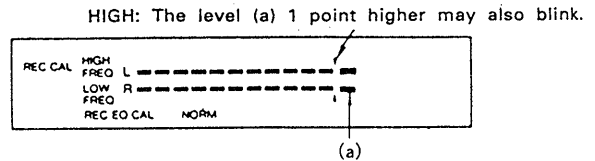

LOW: The level (a) 1 point higher should not blink.

Adjustment Location:

Main (A) PCB - Component side -

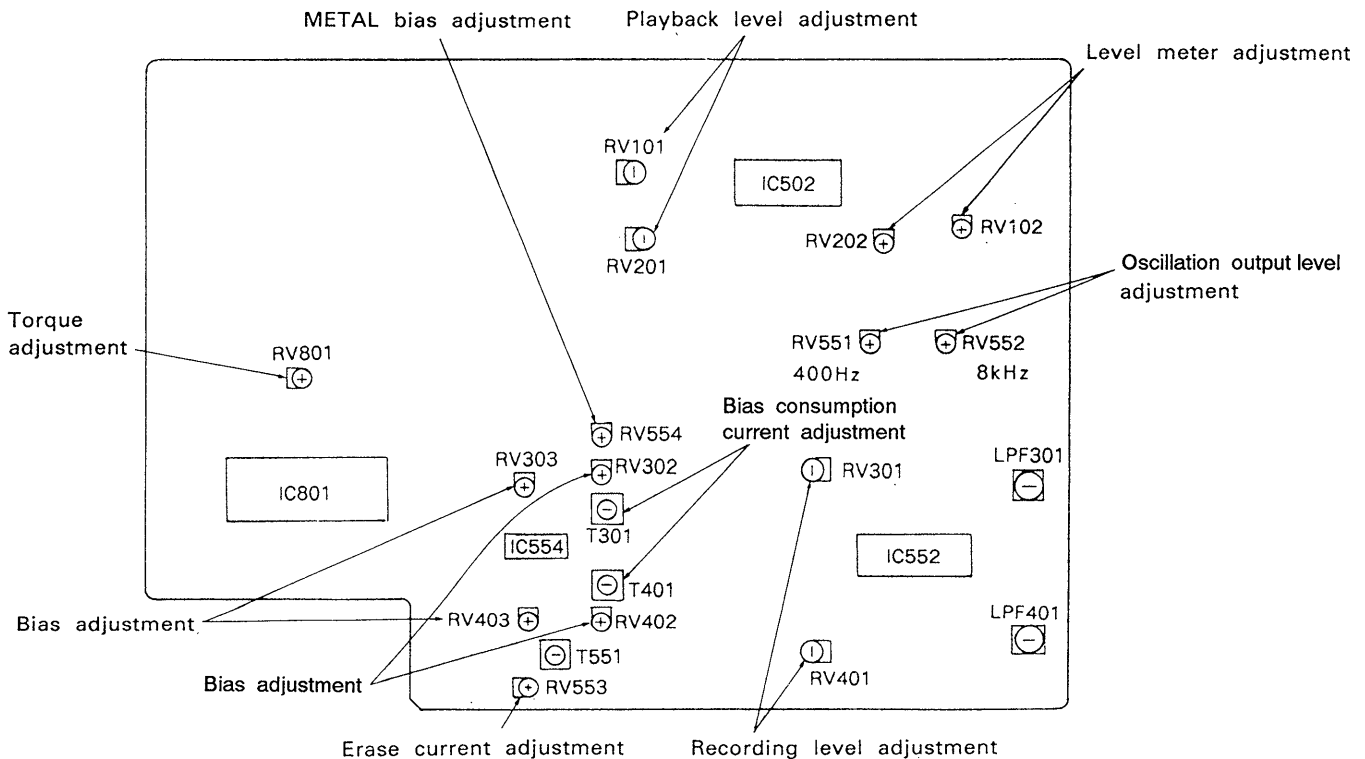

SECTION 3 EXPLODED VIEWS

NOTE:



- -XX,-X mean standardized parts, so they may have some difference from the original one.
- Color indication of Appearance Parts.

Example:

KNOB,BALANCE (WHITE) . . . (RED)

↑	↑
Parts	Cabinet's
Color	Color

- Items marked "*" are not stocked since they are seldom required for routine service. Some delay should be anticipated when ordering these items.
- The mechanical parts with no reference number in the exploded views are not supplied.
- Hardware (# mark) list is given in the last of this parts list.
- Abbreviation
CND : Canadian model
G : Germany model

The components identified by mark  or dotted line with mark  are critical for safety.
Replace only with part number specified.

Les composants identifiés par une marque  sont critiques pour la sécurité.
Ne les remplacer que par une pièce portant le numéro spécifié.

(1) CHASSIS SECTION

- B: Panel (B) board
- C: Panel (C) board
- D: Panel (D) board
- E: Panel (E) board

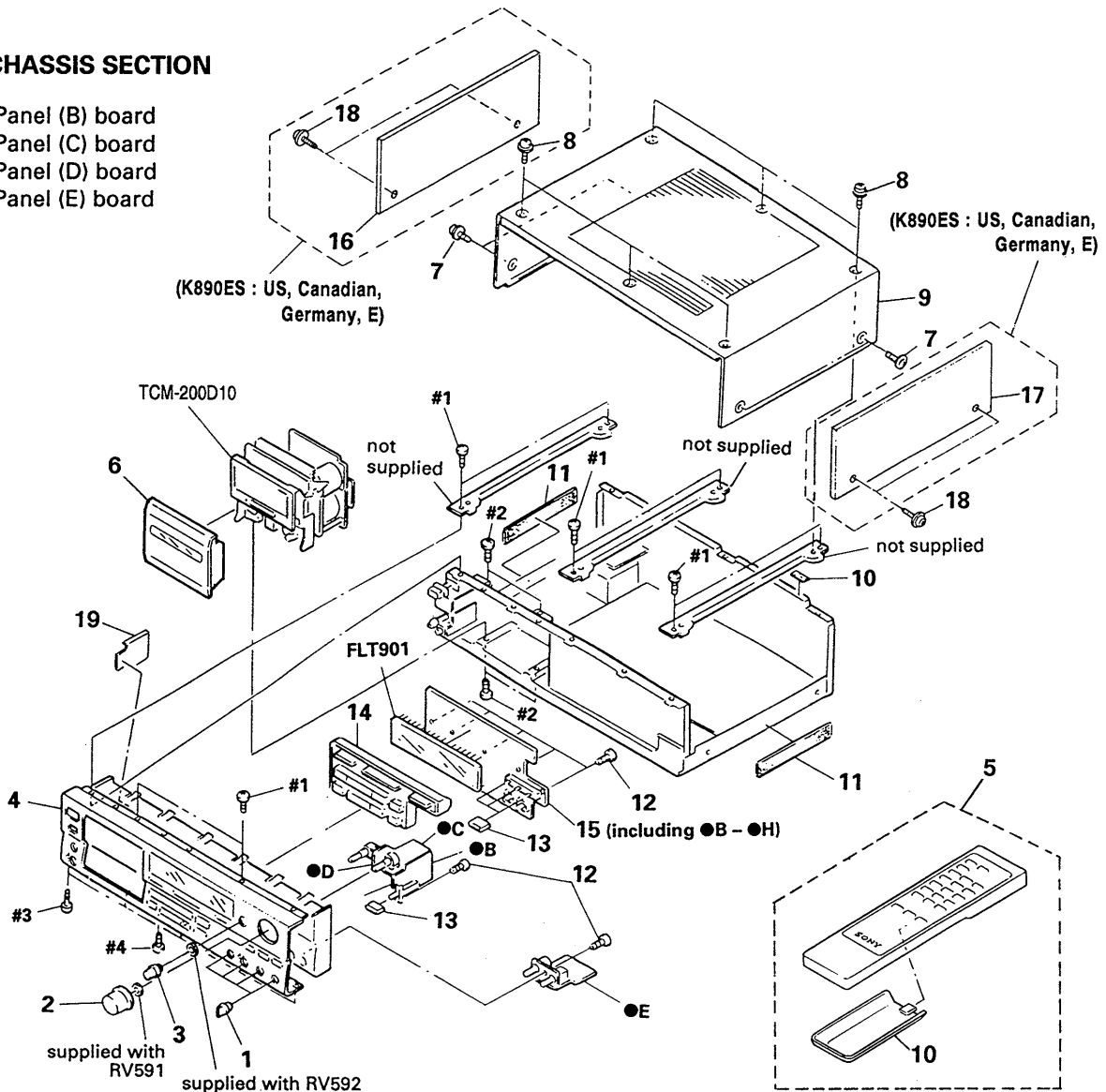

Ref. No.	Part No.	Description	Remark
1	X-3362-818-1	KNOB (DIA. 12) ASSY (B), FLAT... (BLACK) (K890ES:US, CND, E, G/K222ESA)	
1	X-3363-490-1	KNOB (DIA. 12) ASSY (B), FLAT... (GOLD) (K890ES:G)	
2	X-3362-289-1	KNOB (VOL) ASSY... (BLACK) (K890ES:US, CND, E, G/K222ESA)	
2	X-3365-344-1	KNOB (VOL) ASSY... (GOLD) (K890ES:G)	
3	3-364-173-01	KNOB (BAL)... (BLACK) (K890ES:US, CND, E, G/K222ESA)	
3	3-364-173-21	KNOB (BAL)... (GOLD) (K890ES:G)	
4	A-2003-940-A	PANEL ASSY, FRONT (K222ESA)	
4	A-2004-042-A	PANEL ASSY, FRONT (K890ES:US, CND)	
4	A-2004-073-A	PANEL ASSY, FRONT... (BLACK) (K890ES:G)	
4	A-2004-079-A	PANEL ASSY, FRONT (K890ES:E)	
4	A-2004-122-A	PANEL ASSY, FRONT... (GOLD) (K890ES:G)	
5	1-465-314-11	REMOTE COMMANDER (RM-J701)* (K890ES:E/K222ESA)	
6	X-3363-745-1	LID ASSY, CASSETTE (K222ESA)	
6	X-3365-079-1	LID ASSY, CASSETTE... (BLACK) (K890ES:US, CND, E, G)	
6	X-3365-346-1	LID ASSY, CASSETTE... (GOLD) (K890ES:G)	
7	3-704-366-01	SCREW (CASE) (M3X8)	
8	3-704-366-01	SCREW (CASE) (M3X8)... (BLACK) (K890ES:US, CND, E, G/K222ESA)	
8	3-704-366-11	SCREW (CASE) (M3X8)... (GOLD) (K890ES:G)	

Ref. No.	Part No.	Description	Remark
* 9	3-364-366-01	CASE... (BLACK) (K890ES:US, CND, E, G/K222ESA)	
* 9	3-364-366-41	CASE... (GOLD) (K890ES:G)	
10	2-181-754-01	COVER, BATTERY (K890ES:E/K222ESA)	
11	9-911-844-XX	CUSHION (50X20)	
12	4-951-620-01	SCREW (2.6X8), +BVTP	
13	3-364-165-01	BUTTON (14X5)... (BLACK) (K890ES:US, CND, E, G/K222ESA)	
13	3-364-165-11	BUTTON (14X5)... (GOLD) (K890ES:G)	
14	X-3362-290-1	BUTTON (BLOCK) ASSY... (BLACK) (K890ES:US, CND, E, G/K222ESA)	
14	X-3365-345-1	BUTTON (BLOCK) ASSY... (GOLD) (K890ES:G)	
* 15	A-2006-778-A	PANEL BOARD, COMPLETE	
16	X-3340-188-1	PANEL (R) ASSY, SIDE... (BLACK) (K890ES:US, CND, E, G)	
16	X-3363-178-2	PANEL (R) ASSY, SIDE... (GOLD) (K890ES:G)	
17	X-3340-187-1	PANEL (L) ASSY, SIDE... (BLACK) (K890ES:US, CND, E, G)	
17	X-3363-177-2	PANEL (L) ASSY, SIDE... (GOLD) (K890ES:G)	
18	4-933-446-01	SCREW (SIDE PANEL) (K890ES)	
* 19	3-380-705-01	COVER, SAFETY	
FLT901	1-519-560-21	INDICATOR TUBE, FLUORESCENT	

(2) PANEL SECTION

- A: Main (B) board
- F: Panel (F) board
- G: Panel (G) board
- H: Panel (H) board

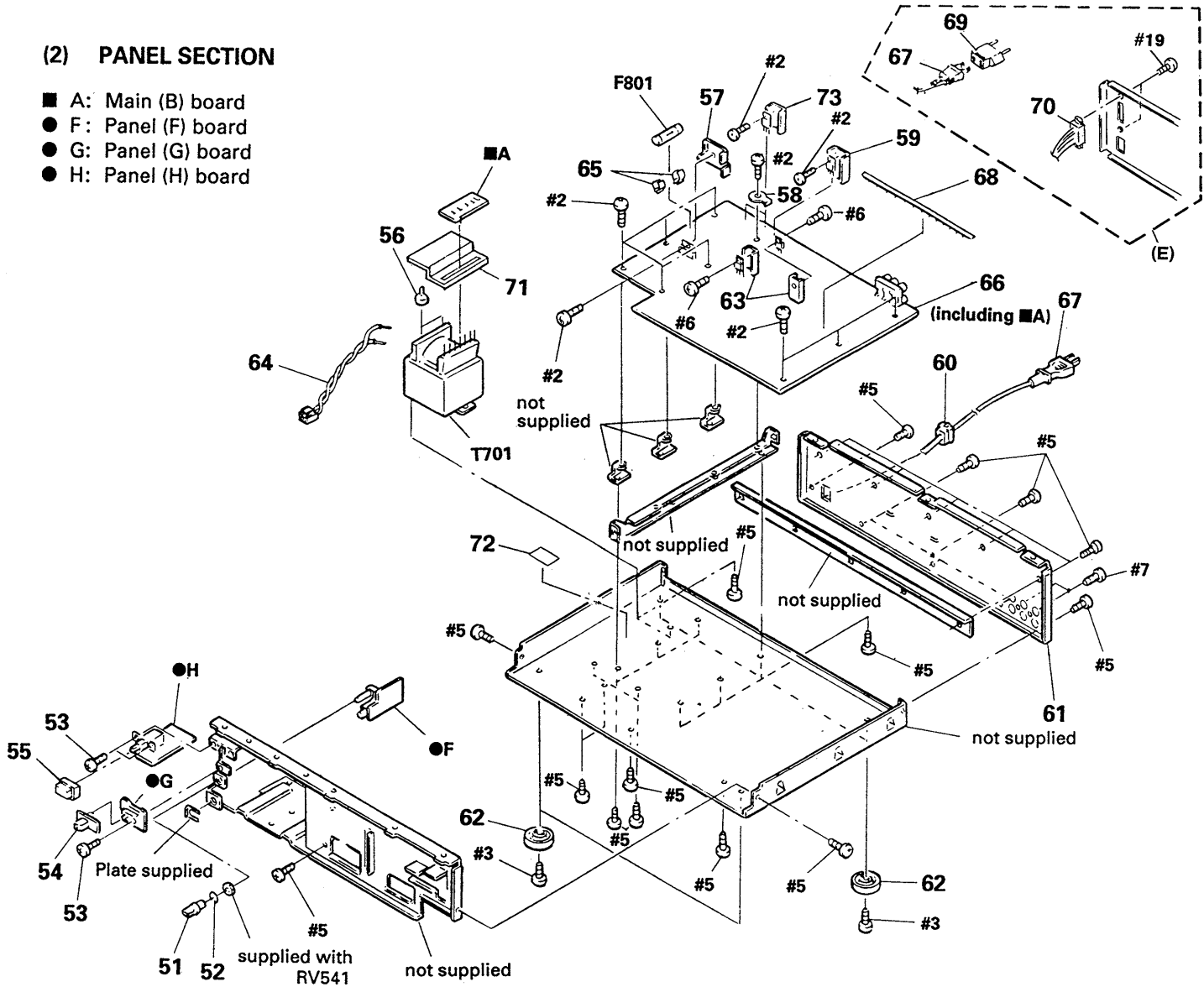

Ref. No.	Part No.	Description	Remark	Ref. No.	Part No.	Description	Remark
51	3-354-931-01	KNOB (DIA. 10)... (BLACK) (K890ES:US, CND, E, G/K222ESA)		62	X-3304-944-1	FOOT ASSY... (BLACK) (K890ES:US, CND, E, G/K222ESA)	
51	3-354-931-31	KNOB (DIA. 10)... (GOLD) (K890ES:G)		62	X-3363-489-1	FOOT ASSY... (GOLD) (K890ES:G)	
52	3-354-981-01	SPRING (SUS), RING... (BLACK) (K890ES:US, CND, E, G/K222ESA)		* 63	4-870-273-00	HEAT SINK (E) (K890ES:G)	
52	3-356-935-01	SPRING... (GOLD) (K890ES:G)		63	4-902-345-01	HEAT SINK (K890ES:US, Canadian, E/K222ESA)	
53	4-951-620-01	SCREW (2. 6X8), +BVTP		* 64	1-590-321-51	LEAD (WITH CONNECTOR)	
54	4-922-518-01	KNOB (TIMER)... (BLACK) (K890ES:US, CND, E, G/K222ESA)		* 65	1-533-213-31	HOLDER, FUSE	
54	4-922-518-62	KNOB (TIMER)... (GOLD) (K890ES:G)		* 66	A-2006-777-A	MAIN BOARD, COMPLETE (K890ES:US, CND, E, G/K222ESA)	
55	3-354-912-01	KNOB, POWER... (BLACK) (K890ES:US, CND, E, G/K222ESA)		* 66	A-2006-779-A	MAIN BOARD, COMPLETE (K890ES:G)	
55	4-917-460-51	KNOB, POWER... (GOLD) (K890ES:G)		△67	1-575-651-11	CORD, POWER (K890ES:G)	
* 56	4-912-962-01	COVER (1P), TERMINAL (K890ES:US, CND, G)		△67	1-575-653-11	CORD, POWER (K890ES:E/K222ESA)	
* 57	3-356-925-01	HEAT SINK		△67	1-575-975-11	CORD, POWER (K890ES:US, CND)	
58	4-870-539-00	PLATE, GROUND		* 68	1-560-242-91	BUS BAR 10P	
* 59	3-309-144-21	HEAT SINK		△69	1-569-007-11	ADAPTER, CONVERSION 2P (K890ES:E/K222ESA)	
* 60	3-703-244-00	BUSHING (2104), CORD (K890ES:US, CND, G)		△70	1-692-155-11	SELECTOR, POWER VOLTAGE (K890ES:E/K222ESA)	
* 60	3-703-571-11	BUSHING (S) (4516), CORD (K890ES:E/K222ESA)		* 71	3-356-961-02	COVER (TRANSFORMER) (K890ES:E/K222ESA)	
* 60	3-703-571-11	BUSHING (S) (4516), CORD (K890ES:E/K222ESA)		* 72	3-703-044-26	LABEL, CAUTION (K890ES:US, CND)	
* 61	3-372-370-11	PANEL, BACK (K890ES:US, CND)		* 73	4-880-403-11	HEAT SINK	
* 61	3-372-370-31	PANEL, BACK... (BLACK) (K890ES:G)		△F801	1-532-285-00	FUSE, TIME-LAG (1. 25A) (K890ES:E, G/K222ESA)	
* 61	3-372-370-41	PANEL, BACK (K222ESA)		△F801	1-532-741-11	FUSE, GLASS TUBE (1. 25A) (K890ES:US, CND)	
* 61	3-372-370-71	PANEL, BACK (K890ES:E)		△T701	1-450-855-11	TRANSFORMER, POWER (K890ES:E/K222ESA)	
* 61	3-372-370-81	PANEL, BACK... (GOLD) (K890ES:G)		△T701	1-450-856-11	TRANSFORMER, POWER (K890ES:G)	
				△T701	1-450-857-11	TRANSFORMER, POWER (K890ES:US, CND)	

(3) MECHANISM SECTION 1 (TCM-200D10)

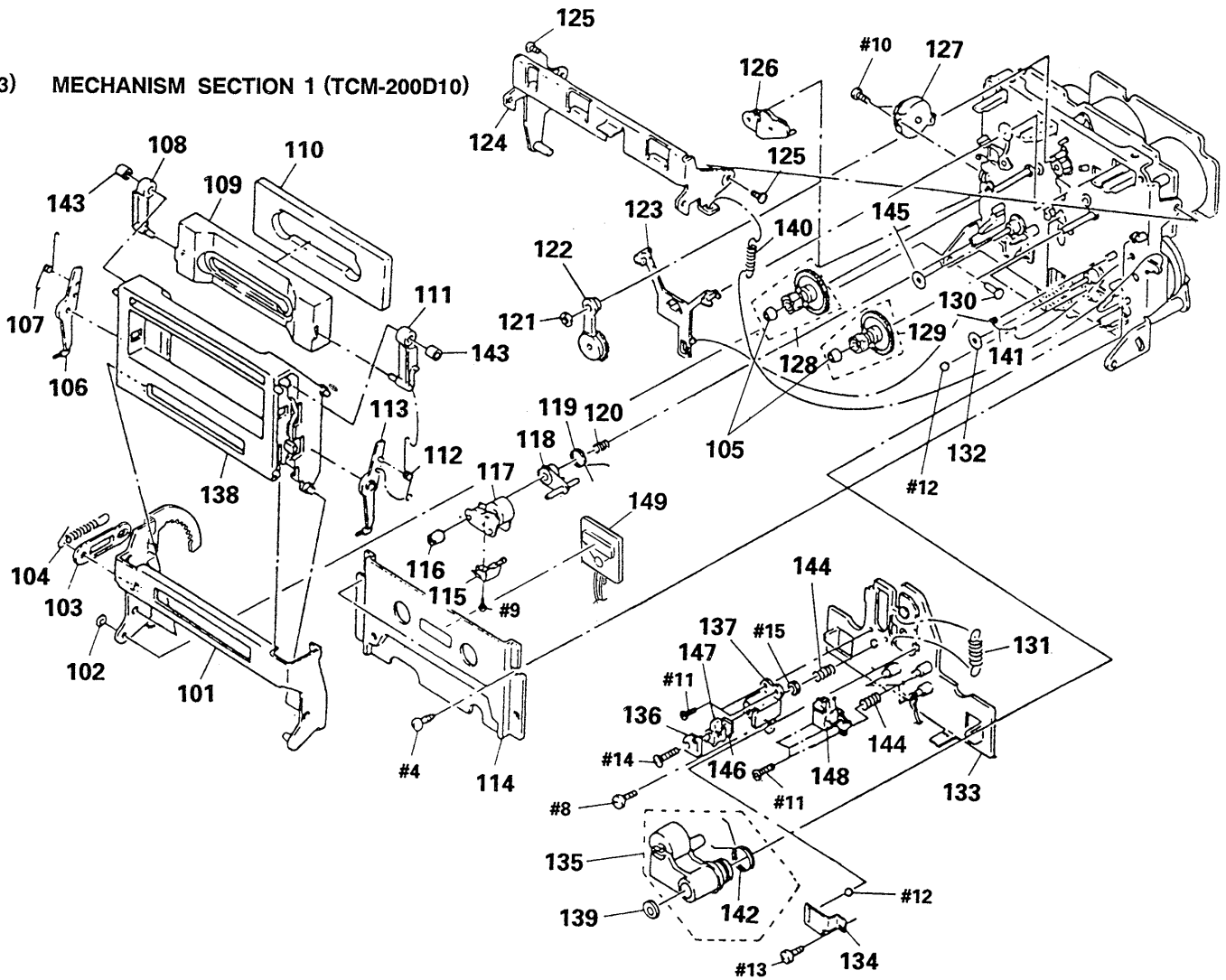

Ref. No.	Part No.	Description	Remark	Ref. No.	Part No.	Description	Remark
101	X-3362-671-1	HOLDER (BG) ASSY, CASSETTE		126	X-3356-623-1	LEVER (BT) ASSY	
102	3-558-708-11	WASHER, STOPPER		127	3-319-224-41	DAMPER, SMALL	
* 103	3-356-717-01	LEVER (JOINT)		128	X-3356-629-1	GEAR (S) ASSY	
104	3-356-626-01	SPRING, TENSION		129	X-3356-627-1	GEAR (T) ASSY	
105	3-362-308-01	CAP (REEL)		130	3-356-710-01	SHAFT (LEFT) (CASSETTE HOLDER)	
106	3-356-932-01	LEVER (LA)		131	3-356-658-01	SPRING (LIMITER H), TENSION	
107	3-356-927-01	SPRING (LEFT), TORSION		132	3-332-763-01	RING, OIL RESERVOIR	
108	3-356-933-01	LEVER (LB)		* 133	X-3362-199-1	SLIDER (HEAD CHASSIS D) ASSY	
109	3-356-928-11	PLATE (A), ORNAMENTAL		134	3-356-656-01	SPRING (HEAD PC BOARD), LEAF	
* 110	3-356-929-01	ABSORBENT, VIBRATION		135	X-3356-620-1	LEVER (PINCH LEVER T) ASSY	
111	3-356-931-01	LEVER (RB)		136	3-318-433-01	SPRING	
112	3-356-926-01	SPRING (RIGHT), TORSION		* 137	3-576-977-00	BRACKET, E. HEAD	
113	3-356-930-01	LEVER (RA)		138	X-3365-065-1	HOLDER (D9) ASSY, CASSETTE	
114	X-3356-613-1	PLATE ASSY, ORNAMENTAL		139	3-669-596-00	WASHER (2.3), STOPPER	
115	3-564-138-00	GUIDE (S), TAPE		140	3-356-625-01	SPRING, TENSION	
116	3-356-652-01	NUT (PINCH LEVER S)		141	3-356-619-01	SPRING (B), TORSION	
117	X-3356-621-1	LEVER (PINCH LEVER S) ASSY		142	3-356-672-01	SPRING (PINCH LEVER T), TORSION	
118	3-356-660-01	LEVER (PS)		143	3-356-946-01	BUSHING	
119	3-356-661-01	SPRING (PINCH LEVER S), TORSION		144	3-564-121-00	SPRING, COMPRESSION	
120	3-356-657-01	SPRING (PS), COMPRESSION		145	3-356-713-01	WASHER	
121	3-669-465-00	WASHER (1.5), STOPPER		* 146	1-608-268-00	PC BOARD, ERASE HEAD	
122	X-3356-641-1	LEVER (FR2) ASSY		147	1-543-836-11	HEAD, MAGNETIC (ERASE)	
123	3-356-614-01	SLIDER (BRAKE)		148	1-543-684-21	HEAD, MAGNETIC (REC/PB) (RPA709-3602A)	
* 124	X-3356-608-1	LEVER (LIFTER) ASSY		149	8-719-980-85	LED SLF325C (CASSETTE LAMP) (GREEN)	
125	3-356-601-11	SCREW, STEP					

(4) MECHANISM SECTION 2 (TCM-200D10)

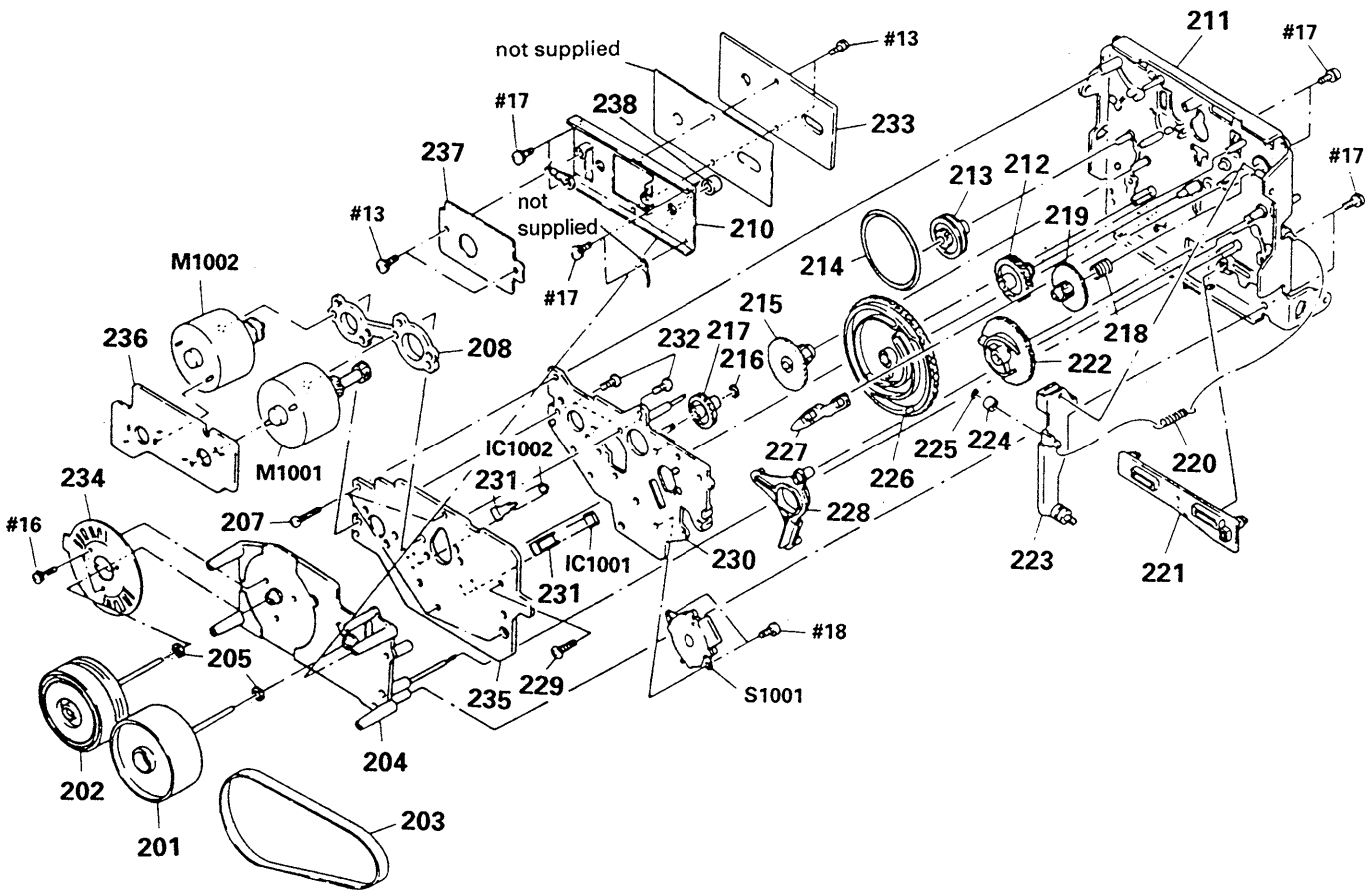

Ref. No.	Part No.	Description	Remark	Ref. No.	Part No.	Description	Remark
201	X-3362-284-1	FLYWHEEL (S2.3) ASSY		* 223	X-3356-606-1	LEVER (LOADING) ASSY	
202	X-3356-619-1	FLYWHEEL (DT) ASSY		224	3-356-630-01	ROLLER (LOADING)	
203	3-364-600-01	BELT (CAPSTAN)		225	3-558-708-21	WASHER, STOPPER	
204	X-3362-281-1	CHASSIS (D2.3) ASSY		226	3-356-654-01	GEAR (MODE CAM C)	
205	3-356-705-31	WASHER (CAPSTAN)		227	3-356-617-01	LEVER (SELECTION)	
207	3-355-801-01	SCREW (BTP 2X18)		228	3-356-613-01	LEVER (MODE)	
* 208	3-356-628-01	SPACER (MOTOR)		229	3-356-707-01	SCREW (+PTPW 2X25)	
* 210	X-3362-282-1	BRACKET (THRUST RETAINER) ASSY		* 230	X-3356-616-1	BRACKET (MOTOR D) ASSY	
211	X-3356-622-1	CHASSIS (C) ASSY, MECHANICAL		231	3-356-631-01	HOLDER (SENSOR)	
212	3-356-703-01	GEAR (COMMUNICATION C)		232	3-363-804-01	SCREW (+P 2.6X6.5)	
213	3-356-607-01	PULLEY (MODE)		233	A-2006-154-A	CAPSTAN C. O. C BOARD, COMPLETE	
214	3-356-603-01	BELT (MODE)		234	1-632-779-11	PC BOARD, FG	
215	3-356-606-01	GEAR (MODE)		* 235	1-632-740-11	MD BOARD	
216	3-669-465-11	WASHER (1.5), STOPPER		* 236	1-632-741-11	REEL MOTOR BOARD	
217	3-356-702-01	GEAR (COMMUNICATION B)		* 237	1-632-746-11	COMPARATOR BOARD	
218	3-356-605-01	SPRING, COMPRESSION		238	3-364-135-01	RETAINER (S), THRUST	
219	3-356-609-01	GEAR (LOADING)		M1001	X-3356-638-1	MOTOR (REEL R) ASSY	
220	3-376-854-01	SPRING, TENSION		M1002	X-3356-604-1	MOTOR (ASSIST) ASSY	
221	3-356-653-01	SLIDER (PAUSE)		S1001	1-466-238-11	ENCODER, ROTARY	
222	3-356-616-01	GEAR (LOADING CAM)					

SECTION 4 ELECTRICAL PARTS LIST

The following parts differ from those in TC-K222ESL/K870ES.

NOTE :

- RESISTORS
All resistors are in ohms
- Items marked "*" are not stocked since they are seldom required for routine service. Some delay should be anticipated when ordering these items.

No.	Part No.	Description	Remarks
	* A-2006-777-A	MAIN BOARD, COMPLETE (K890ES; US, Canadian, E / K222ESA)	
	* A-2006-779-A	MAIN BOARD, COMPLETE (K890ES; Germany) *****	
		< RESISTOR >	
R118	1-247-719-11	CARBON 3.3K 5%	1/4W
R119	1-247-719-11	CARBON 3.3K 5%	1/4W
R137	1-249-427-11	CARBON 6.8K 5%	1/4W
R218	1-247-719-11	CARBON 3.3K 5%	1/4W
R219	1-247-719-11	CARBON 3.3K 5%	1/4W
R237	1-249-427-11	CARBON 6.8K 5%	1/4W
R310	1-247-128-00	CARBON 750 5%	1/4W
R312	1-247-719-11	CARBON 3.3K 5%	1/4W
R313	1-247-719-11	CARBON 3.3K 5%	1/4W
R410	1-247-128-00	CARBON 750 5%	1/4W
R412	1-247-719-11	CARBON 3.3K 5%	1/4W
R413	1-247-719-11	CARBON 3.3K 5%	1/4W
		< VARIABLE RESISTOR >	
RV102	1-238-601-11	ADJ, CARBON 22K (CA METER L)	
RV202	1-238-601-11	ADJ, CARBON 22K (CA METER R)	

	* A-2006-778-A	PANEL BOARD, COMPLETE *****	
		< INDICATOR TUBE >	
FLT901	1-519-560-21	INDICATOR TUBE, FLUORESCENT	

		MISCELLANEOUS *****	
	1-543-684-21	HEAD, MAGNETIC (REC/PB)(RPA709-3602A)	
	1-543-836-11	HEAD, MAGNETIC (ERASE)	
	1-692-155-11	SELECTOR, POWER VOLTAGE (K890ES; E / K222ESA)	
T701	△ 1-450-855-11	TRANSFORMER, POWER (K890ES; E / K222ESA)	
T701	△ 1-450-856-11	TRANSFORMER, POWER (K890ES; Germany)	
T701	△ 1-450-857-11	TRANSFORMER, POWER (K890ES; US, Canadian)	

No.	Part No.	Description	Remarks
		ACCESSORY & PACKING MATERIAL *****	
	* 3-354-919-51	INDIVIDUAL CARTON (K890ES)	
	* 3-366-699-91	INDIVIDUAL CARTON (K222ESA)	
	* 3-754-181-11	MANUAL, INSTRUCTION (ENGLISH/FRENCH/SPANISH/GERMAN) (K222ESA, K890ES; Canadian, Germany, E)	
	* 3-754-181-21	MANUAL, INSTRUCTION (ENGLISH) (K890ES; US)	

		***** HARDWARE LIST *****	
#1	7-682-548-04	SCREW +BVTT 3X8 (S)	
#2	7-682-547-04	SCREW +BVTT 3X6 (S)	
#3	7-682-548-09	SCREW +BVTT 3X8 (S)	
#4	7-685-133-19	SCREW +BTP 2.6X6 TYPE2 N-S	
#5	7-682-547-09	SCREW +BV 3X6, S TIGHT	
#6	7-682-147-15	SCREW, TR (+P 3X6)	
#7	7-621-849-00	SCREW (BV/RING)	
#8	7-621-775-10	SCREW +B 2.6X4	
#9	7-628-253-00	SCREW +PS 2X4	
#10	7-621-255-20	SCREW +BVTT 2X4 (S)	
#11	7-621-772-10	SCREW +B 2X4	
#12	7-671-154-01	STENLESS BALL	
#13	7-685-870-01	SCREW +BVTT 3X5 (S)	
#14	7-621-772-70	SCREW +B 2X14	
#15	7-622-205-05	NUT M2 TYPE2	
#16	7-628-254-10	SCREW +PS 2.6X6	
#17	7-682-648-09	SCREW +PS 3X8	
#18	7-621-255-35	SCREW +BVTT 2X5 (S)	
#19	7-685-646-79	SCREW +BVTP 3X8 TYPE2 N-S (K890ES; E / K222ESA)	

The components identified by mark △ or dotted line with mark △ are critical for safety. Replace only with part number specified.

Les composants identifiés par une marque △ sont critiques pour la sécurité. Ne les remplacer que par une pièce portant le numéro spécifié.

When indicating parts by reference number, please include the board name.