

TC-W490

SERVICE MANUAL

US Model
Canadian Model
AEP Model
UK Model
E Model

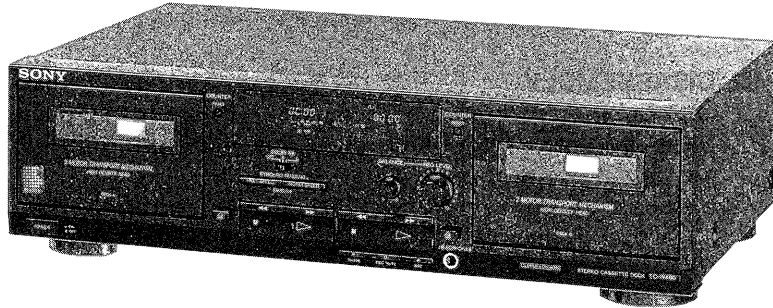

SPECIFICATIONS

Recording system 4-track 2-channel stereo
Fast winding time Approx. 90 sec. (with Sony C-60 cassette)
Bias AC bias
Signal-to-noise ratio (at peak level)

Cassette (Dolby NR OFF)	Type IV (Sony Metal-S)	Type II (Sony UX-S)	Type I (Sony HF-S)
	58 dB	57 dB	55 dB

Measured at peak level weighted without NR. The S/N is improved by about 15 dB at 500 Hz and by about 20 dB about 1 kHz with Dolby-C NR on, and by 5 dB at 1 kHz and by 10 dB about 5 kHz with Dolby-B NR on.

Harmonic distortion 0.4% (with Sony Type I, 160 nWb/m, 315 Hz, 3rd H.D.)
1.8% (with Sony Type IV, 250 nWb/m, 315 Hz, 3rd H.D.)

Frequency response (DOLBY NR OFF)

Type IV cassette (Sony Metal-S)	30 - 18,000 Hz (± 3 dB, IEC) 30 - 13,000 Hz (± 3 dB (-4 dB) recording)
Type II cassette (Sony UX-S)	30 - 17,000 Hz (± 3 dB, IEC)
Type I cassette (Sony HF-S)	30 - 15,000 Hz (± 3 dB, IEC)

Wow and flutter $\pm 0.14\%$ W.Peak (IEC)
0.08% W.RMS (NAB)
 $\pm 0.19\%$ W.Peak (DIN)

Inputs

Line inputs (phono jacks)	Sensitivity	0.16 V
	Input impedance	47 kilohms

Outputs

Line outputs (phono jacks)	Rated output level	0.5 V at a load impedance of 47 kilohms
	Load impedance	Over 10 kilohms
Headphones (stereo phone jack)	Output level	1 mW at a load impedance of 32 ohms

Model Name Using Similar Mechanism	TC-W320/W370	
Tape Transport Mechanism Type	DECK A	TCM-190VA12CS
	DECK B	TCM-190VB12CS

General

Power requirements

US, Canadian Model :
120V AC, 60 Hz
AEP Model :
220-230V AC, (or 240V AC adjustable by Sony personnel), 50/60 Hz
UK Model :
240V AC (or 220V AC adjustable by Sony personnel), 50/60 Hz
E Model :
120, 220 or 240V AC adjustable, 50/60 Hz

Power consumption 23 W
Dimensions

Approx. 430 × 123 × 285 mm (w/h/d)
(17 × 47/8 × 11 1/4 inches) including projecting parts and controls
Approx. 4.5 kg (9 lbs 15 oz)

Weight

Supplied accessories

Audio connecting cords (2)

Design and specifications subject to change without notice.

Note

This appliance conforms with EEC Directive 87/308/EEC regarding interference suppression.

Dolby noise reduction manufactured under license from Dolby Laboratories Licensing Corporation.

"DOLBY" and the double-D symbol  are trademarks of Dolby Laboratories Licensing Corporation.

STEREO CASSETTE DECK
SONY®



TABLE OF CONTENTS

<i>Section</i>	<i>Title</i>	<i>Page</i>
Specifications		1
Safety Check-out		3
1. GENERAL		
1-1. Identifying the Parts		4
2. DISASSEMBLY		
2-1. Front Panel		5
2-2. Mechanism Deck		5
2-3. Capstan Motor, Reel Motor		6
2-4. Head, Pinch Roller		6
3. EXPLANATION OF IC TERMINALS		7
4. ADJUSTMENTS		
4-1. Mechanical Adjustments		9
4-2. Electrical Adjustments		9
5. DIAGRAMS		
5-1. Block Diagram		13
5-2. Printed Wiring Boards		18
5-3. Schematic Diagram (System control section)		23
5-4. Schematic Diagram (audio section)		28
6. EXPLODED VIEWS		
6-1. Chassis Section		33
6-2. Front Panel Section		34
6-3. Mechanism Section 1		35
6-4. Mechanism Section 2		36
7. ELECTRICAL PARTS LIST		35

MODEL IDENTIFICATION
(Specification Label)

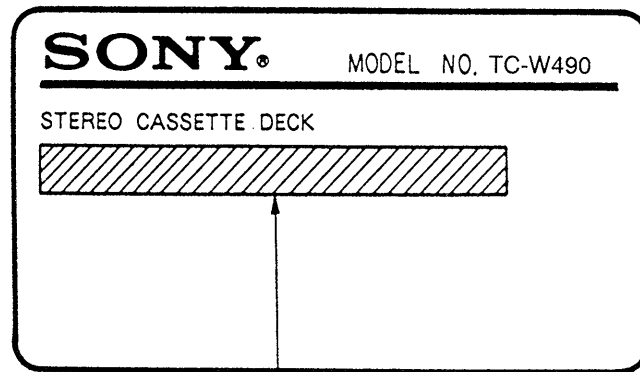

US, Canadian model : AC120V 60Hz 23W
 AEP, Germany model : AC220-230V ~ 50/60Hz
 UK model : AC240V ~ 50/60Hz
 E model : AC120, 220, 240V ~ 50/60Hz 23W

SAFETY CHECK-OUT

After correcting the original service problem, perform the following safety check before releasing the set to the customer:

Check the antenna terminals, metal trim, "metallized" knobs, screws, and all other exposed metal parts for AC leakage. Check leakage as described below.

LEAKAGE TEST

The AC leakage from any exposed metal part to earth ground and from all exposed metal parts to any exposed metal part having a return to chassis, must not exceed 0.5 mA (500 microamperes). Leakage current can be measured by any one of three methods.

1. A commercial leakage tester, such as the Simpson 229 or RCA WT-540A. Follow the manufacturers' instructions to use these instruments.
2. A battery-operated AC milliammeter. The Data Precision 245 digital multimeter is suitable for this job.

3. Measuring the voltage drop across a resistor by means of a VOM or battery-operated AC voltmeter. The "limit" indication is 0.75 V, so analog meters must have an accurate low-voltage scale. The Simpson 250 and Sanwa SH-63Trd are examples of a passive VOM that is suitable. Nearly all battery operated digital multimeters that have a 2V AC range are suitable. (See Fig. A)

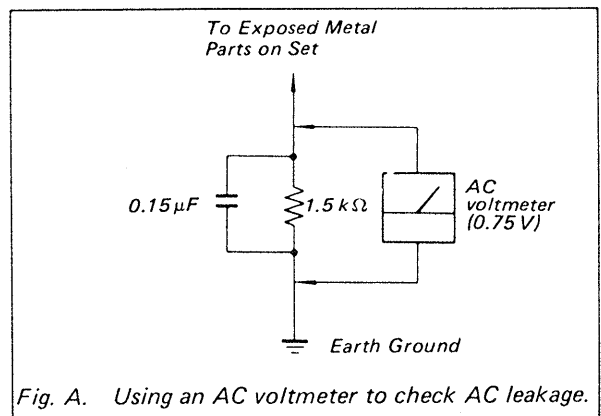





Fig. A. Using an AC voltmeter to check AC leakage.

SAFETY-RELATED COMPONENT WARNING!!

COMPONENTS IDENTIFIED BY MARK  OR DOTTED LINE WITH MARK  ON THE SCHEMATIC DIAGRAMS AND IN THE PARTS LIST ARE CRITICAL TO SAFE OPERATION. REPLACE THESE COMPONENTS WITH SONY PARTS WHOSE PART NUMBERS APPEAR AS SHOWN IN THIS MANUAL OR IN SUPPLEMENTS PUBLISHED BY SONY.

ATTENTION AU COMPOSANT AYANT RAPPORT À LA SÉCURITÉ!

LES COMPOSANTS IDENTIFIÉS PAR UNE MARQUE  SUR LES DIAGRAMMES SCHÉMATIQUES ET LA LISTE DES PIÈCES SONT CRITIQUES POUR LA SÉCURITÉ DE FONCTIONNEMENT. NE REMPLACER CES COMPOSANTS QUE PAR DES PIÈCES SONY DONT LES NUMÉROS SONT DONNÉS DANS CE MANUEL OU DANS LES SUPPLÉMENTS PUBLIÉS PAR SONY.

SECTION 1 GENERAL

This section is extracted from instruction manual.

1-1. IDENTIFYING THE PARTS

Front Panel

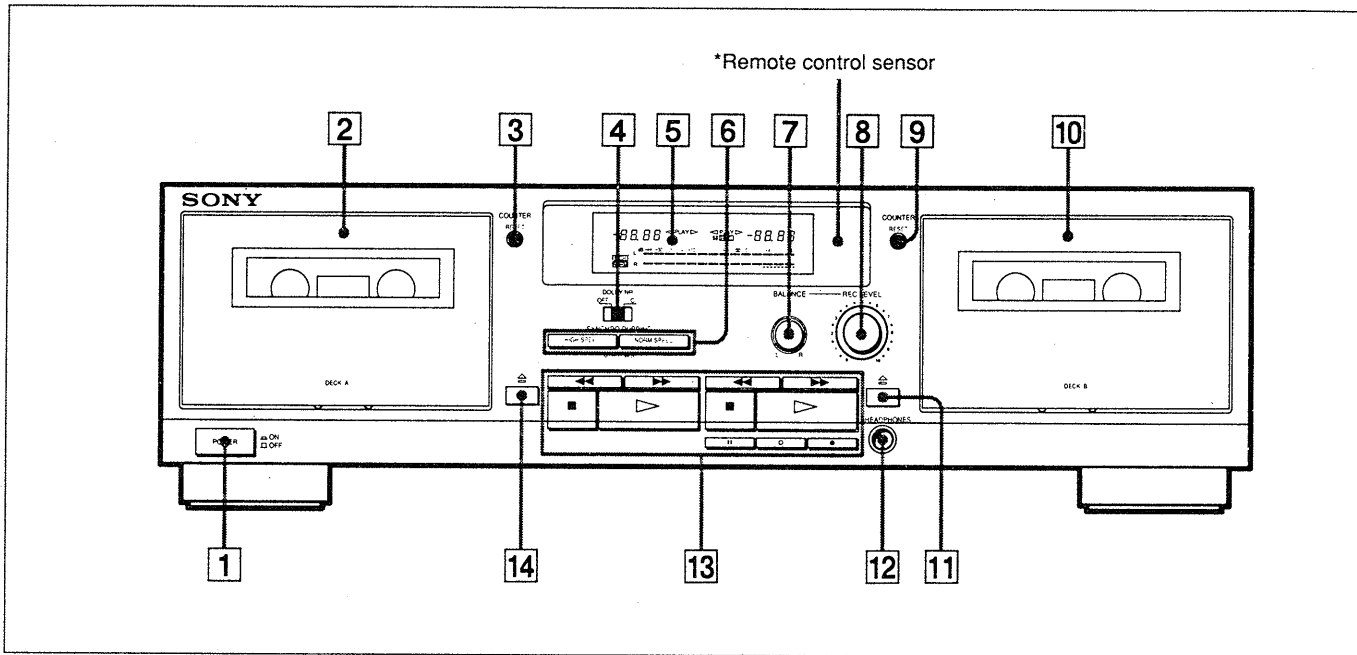



For details, refer to the page number indicated in parenthesis.

- 1** POWER switch
- 2** Deck A
- 3** COUNTER RESET button (deck A)
- 4** DOLBY NR (Dolby noise reduction) switch
- 5** Display panel
- 6** SYNCHRO DUBBING buttons
HIGH SPEED button
NORM (normal) SPEED button
- 7** BALANCE control
- 8** REC (recording) LEVEL control
- 9** COUNTER RESET button (deck B)
- 10** Deck B
- 11** ▲ (eject) button (deck B)
- 12** HEADPHONES (headphones) jack (stereo phone jack)

- 13** Tape operation buttons
◀◀ (leftward fast winding) button
▶▶ (rightward fast winding) button
■ (stop) button
▶ (forward play) button
|| PAUSE button (deck B only)
○ REC MUTE (record muting) button (deck B only)
● REC (recording) button (deck B only)
- 14** ▲ (eject) button (deck A)

*Remote control sensor

You can remotely control this cassette deck with:

- A remote commander that came with a Sony amplifier or receiver if it has the  mark and cassette deck control capability.
- Any optional Sony remote commander with the  mark and cassette deck control capability.

SECTION 2 DISASSEMBLY

Note : Follow the disassembly procedure in the numerical order given.

CASE
Unscrew the four case attachment screws M3 × 8 and remove the case.

2-1. FRONT PANEL

FRONT PANEL ① - ③
VOLTAGE SELECTOR ① - ②

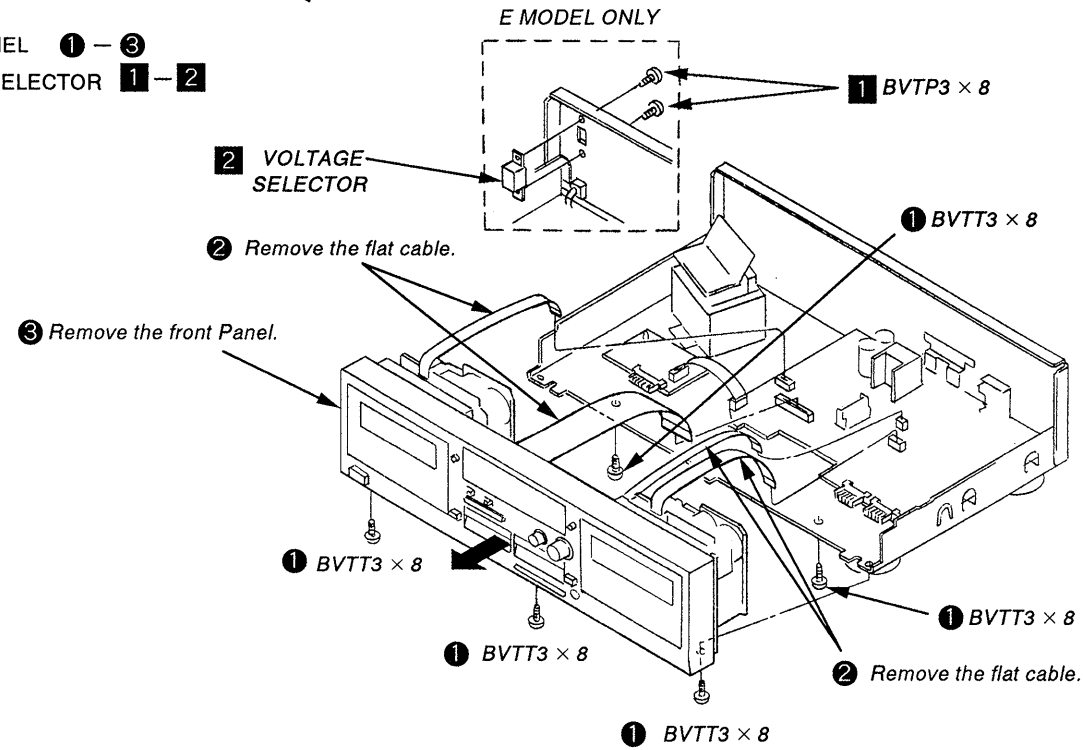

2-2. MECHANISM DECK

① Press the EJECT button.

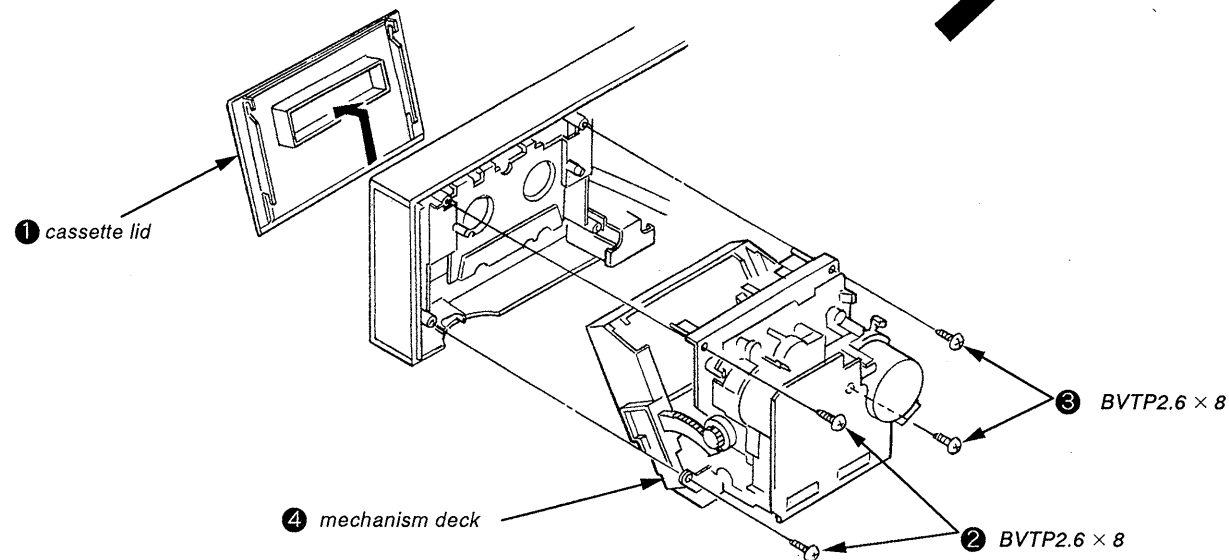

2-3. CAPSTAN MOTOR, REEL MOTOR

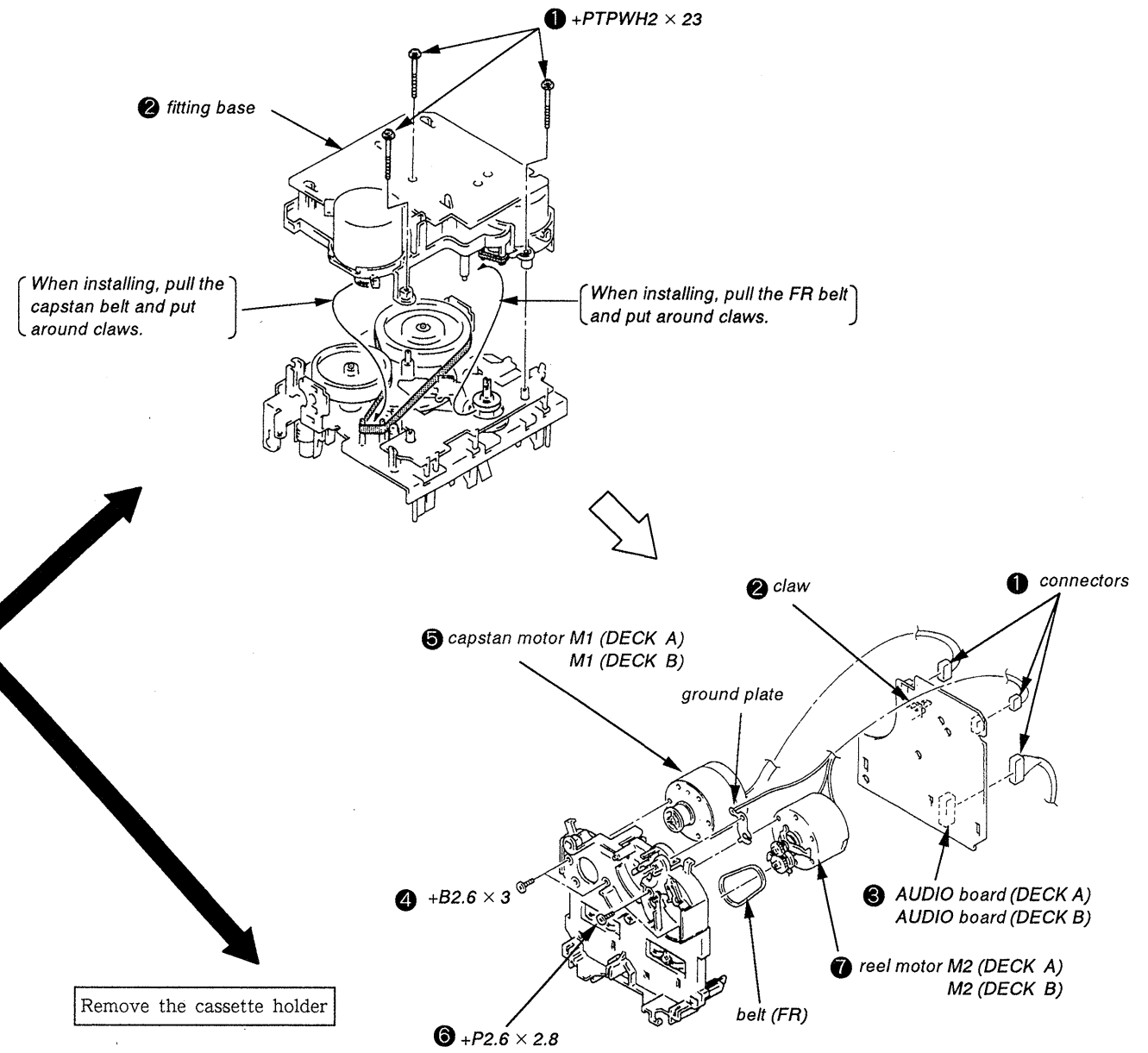

2-4. HEAD, PINCH ROLLER

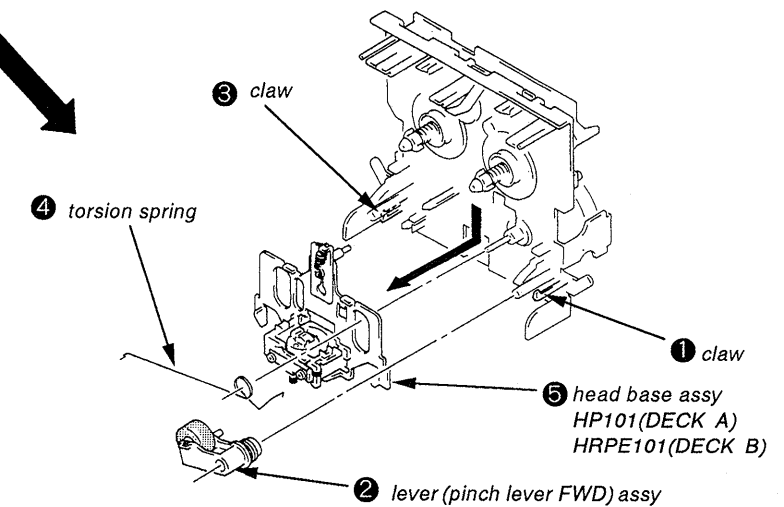

SECTION 3

EXPLANATION OF IC TERMINALS

IC801 M50941-712P

Pin. No.	Terminal name	I/O	Terminal explanation																															
1	VREF		Standard voltage 5V																															
2	METER. L	I	Meter L-CH input																															
3	METER. R	I	Meter R-CH input																															
4	KEY. 1	I	Key input																															
5	KEY. 2	I	Key input																															
6	B. METAL	I	Metal tape detection at B-deck, "L" : Metal claw proof																															
7	B. LSW	I	<table border="1" style="margin-left: auto; margin-right: auto;"> <thead> <tr> <th colspan="3">Switch status</th> <th rowspan="2">Input Voltage</th> </tr> <tr> <th colspan="3">ON...Available OFF...Not Available</th> </tr> <tr> <th>REC A</th> <th>REC B</th> <th>HALF</th> <th></th> </tr> </thead> <tbody> <tr> <td>OFF</td> <td>OFF</td> <td>OFF</td> <td>5V</td> </tr> <tr> <td>ON</td> <td>OFF</td> <td>ON</td> <td>3.9V</td> </tr> <tr> <td>OFF</td> <td>OFF</td> <td>ON</td> <td>2.8V</td> </tr> <tr> <td>ON</td> <td>ON</td> <td>ON</td> <td>2V</td> </tr> <tr> <td>OFF</td> <td>ON</td> <td>ON</td> <td>1V</td> </tr> </tbody> </table>	Switch status			Input Voltage	ON...Available OFF...Not Available			REC A	REC B	HALF		OFF	OFF	OFF	5V	ON	OFF	ON	3.9V	OFF	OFF	ON	2.8V	ON	ON	ON	2V	OFF	ON	ON	1V
Switch status			Input Voltage																															
ON...Available OFF...Not Available																																		
REC A	REC B	HALF																																
OFF	OFF	OFF	5V																															
ON	OFF	ON	3.9V																															
OFF	OFF	ON	2.8V																															
ON	ON	ON	2V																															
OFF	ON	ON	1V																															
8	A. SHUT	I	S-side reel rotation detection at A-deck																															
9	B. SHUT	I	S-side reel rotation detection at B-deck																															
10	VER. SELECT	I	Reverse/1 way "L" : Reverse																															
11	MOT. H/L	O	Tape speed selector "L" Normal, "H" : High																															
12	A. RM +	O	Reel moter (+) output at A-deck, "H" : FF																															
13	A. RM -	O	Reel moter (-) output at A-deck, "H" : REW																															
14	B. RM +	O	Reel moter (+) output at B-deck, "H" : FF																															
15	B. RM -	O	Reel moter (-) output at B-deck, "H" : REW																															
16	RELAY	O	Recording/play selector at B-deck, "L" : Recording																															
17	BIAS	O	Bias ON/OFF at B-deck, "H" : ON																															
18	A/B	O	A-deck/B-deck play selector, at B-deck, "H" : A-deck																															
19	REC/PB	O	Recording/play selector for Dolby IC, "H" : play																															
20	EQ. H/L	O	NORMAL/HIGH selector for recording equalizer, "L" : NORMAL																															
21	REC. MUTE	O	Recording MUTE ON/OFF "L" : ON																															
22	L. MUTE	O	LINE MUTE ON/OFF "L" : ON																															
23	P. OUT	O	Power holding output "L" : Power on holding																															
24	P. IN	I	Power switch input "L" : OFF																															
25	SIRCS	I	SIRCS signal input																															
26	CN - VSS		GND																															
27	RESET	I	RESET signal input																															
28	X - IN	I	Oscillation terminal																															
29	X - OUT	O	Oscillation terminal (4MHz)																															
30	XC - IN		Not used																															
31	XC - OUT		Not used																															
32	VSS		GND																															
33			Not used																															
34	TEST	I	Test mode selector "L" : Test mode																															
35	B. STOPSW	I	Mechanism stop swich input for B-deck "H" : STOP																															

Pin. No.	Terminal name	I/O	Terminal explanation
36	A. STOPSW	I	Mechanism stop switch input for A-deck "H" : STOP
37	A. HALF	I	Half pawl input for A-deck "L" : Available
38	VP	I	Pull-down volatage input for fluoescent (FL) tube
39	B. CM	O	Capstan motor ON/OFF for B-deck, "H" : ON
40	A. CM	O	Capstan motor ON/OFF for A-deck, "H" : ON
41 - 62	7G-P15	O	Fluorescent (FL) tube output
63	AVCC		Analog power input
64	VCC		Power

IC51 CXA1579P

Pin. No.	Terminal name	I/O	Terminal explanation
1	SPEED	I	Tape speed selector terminal "H" : HIGH
2	METAL	I	Metal tape selector terminal "H" : METAL
3	TAPE EQ	I	Tape equalizer selector terminal "H" : CrO ₂
4	REC IN1	I	Recording equalizer amp input terminal
5	GND		
6	BOOST1	I	External capacitor for low-pass boost connecting terminal
7	VEE		
8	REC OUT1	O	Recording equalizer amp output terminal
9	REC OUT2	O	Recording equalizer amp output terminal
10	VCC		
11	BOOST2		External capacitor for low-pass boost connecting terminal
12	IREF	O	Standard current setting terminal of monolithic filter
13	REC IN2	I	Recording equalizer amp input terminal
14	REC CAL	I	Recording calibration terminal "H" : Recording level gain down
15	REC MUTE	I	Recording Mute ON/OFF selector terminal "H" : Mute OFF "L" : Mute ON
16	GP CAL	I	High-pass calibration terminal "H" : High-pass level gain down "L" : High-pass level gain up

SECTION 4 ADJUSTMENTS

4-1. MECHANICAL ADJUSTMENTS

PRECAUTION

1. Clean the following parts with a denatured alcohol-moistened swab:

record/playback/erase head	pinch roller
rubber belts	capstan
idlers	
2. Demagnetize the record/playback head with a head demagnetizer. (Head demagnetizer do not approach for the erase head.)
3. Do not use a magnetized screwdriver for the adjustment.
4. After the adjustments, apply suitable locking compound to the parts adjusted.
5. The adjustments should be performed with the rated power supply voltage unless otherwise noted.

Torque Measurement

Torque	Torque	Meter reading
Forward	CQ-102C	30 to 65g•cm (0.42 to 0.9 oz•inch)
Forward back tension	CQ-102C	DECK A : 1 to 6g•cm (0.014 to 0.08 oz•inch) DECK B : 2 to 9g•cm (0.03 to 0.12 oz•inch)
Reverse	CQ-102RC	30 to 65g•cm (0.42 to 0.9 oz•inch)
Reverse back	CQ-102RC	1 to 6g•cm (0.014 to 0.08 oz•inch)
Forward, Reverse	CQ-201B	70 to 120g•cm (0.98 to 1.67 oz•inch)

4-2. ELECTRICAL ADJUSTMENTS

PRECAUTION

1. The adjustment should be performed in the publication. (Be sure to male playback adjustment at first.)
2. The adjustments and measurement should be performed for both L-CH and R-CH.
 - Switch position

DOLBY NR switch	: OFF
DIR MODE switch	: ⇄
 - Standard record position:
Deliver the standard input signal level to input jack and set the REC LEVEL control to obtain the standard output signal level as follows.

— Record Mode —

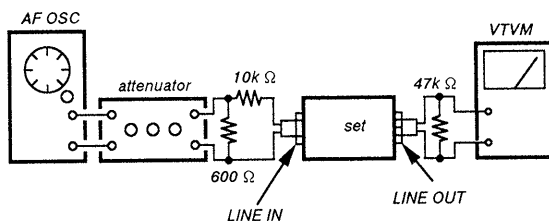

Standard Input Level

Input terminal	LINE IN
source impedance	10k Ω
input signal level	0.5V (- 3.8dB)

Standard Output Level

Output terminal	LINE OUT
load impedance	47k Ω
output signal level	0.5V (- 3.8dB)

Test Tape

Tape	Contents	Use
P-4-A100	10kHz, - 10dB	Azimuth Adjustment
P-4-L300	315Hz, 0dB	PB Level Adjustment
WS-48B	3kHz, 0dB	Tape Speed Adjustment

$0dB=0.775V$

Test Mode

1. Turn ON the power switch to set to test mode while connecting pin ③ of IC801 to ground.
2. Turn OFF the power switch to release the test mode.
3. Executes high speed dubbing when the HIGH SPEED (DUBBING) button is pressed during dubbing. When pressing this button again, the normal speed dubbing is restored.
4. The DECK A and B can be adjusted in the same manner.

Record/Playback Head Azimuth Adjustment Procedure :

1. Forward playback Mode

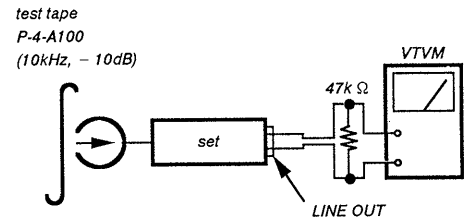

2. Turn the adjustment screw for the maximum output levels. If these levels do not match, turn the adjustment screw until both of output levels match together within 1dB.

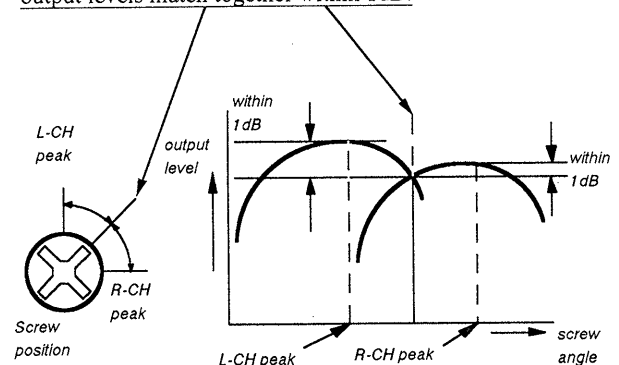

3. Playback Mode

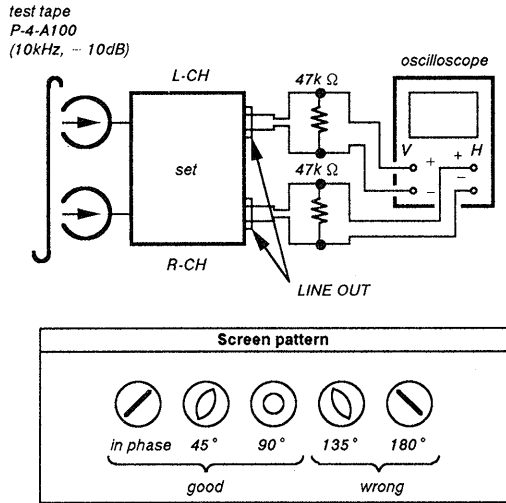

4. Change the reverse playback mode and repeat the steps 1 to 3.
5. After the adjustment, lock the adjustment screws with suitable locking compound.

Adjustment Location : – record/playback head –

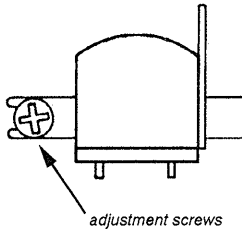

Tape Speed Adjustment

Procedure :

– Forward Playback Mode –

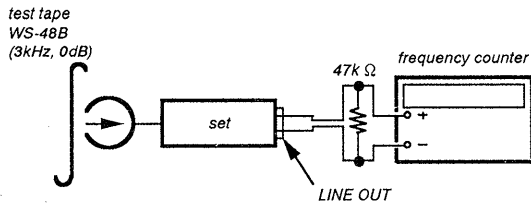

Perform high speed adjustment before normal speed adjustment.

(high speed adjustment)

1. Set to FWD playback mode.
2. Keep on pressing the HIGH SPEED DUBBING switch.
3. Adjust RV72 so that the frequency counter reading becomes $6,000 \pm 20\text{Hz}$.

(normal speed adjustment)

1. Set to FWD playback mode.
2. Adjust RV71 so that the frequency counter reading becomes $3,000 \pm 10\text{Hz}$.

Frequency difference between the beginning and the end of the tape should be within 3%.

Frequency difference between deck A and deck B the beginning of the tape should be within 1.5%.

Adjustment Location : AUDIO board

Playback Level Adjustment

Procedure :

– Forward Playback Mode –

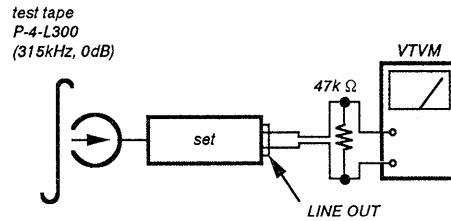

Adjust deck A, B : RV11(L-CH)and RV21(R-CH) so the VTVM reading becomes the adjustment limits below.

Adjustment Value :

LINE OUT level : – $7.7 \pm 0.5\text{dB}$ (0.301 to 0.338V)

Level difference between channels : within 0.5dB

Confirm the LINE OUT level does not change in playback mode while changing the mode from playback to stop several times

Adjustment Location : AUDIO board

Bias Consumption Current Adjustment

This adjustment should be performed when replacing the head assy or the bias oscillating transformer (T81,T91).

Procedure :

() : R-CH

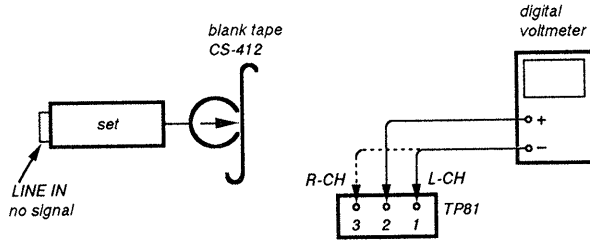

1. Connect the digital voltmeter to test point TP81.
2. Set RV81 (RV91) to mechanical center.
3. Set to FWD record mode.
4. Adjust T81 (T91) so that the digital voltmeter reading becomes minimum.

Adjustment Location : AUDIO board

Record Level Adjustment

Setting :

REC LEVEL control : standard record position (Refer to page 9.)

Procedure :

1. Record Mode

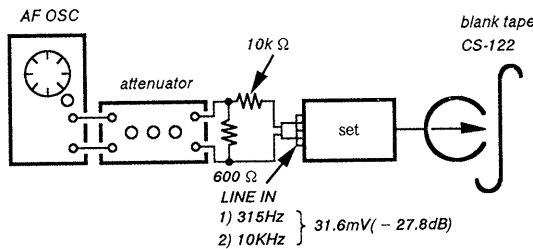

2. Playback Mode

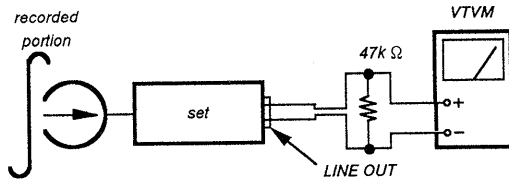

Confirm that the 10kHz playback output is $0 \pm 0.5\text{dB}$ relative to the 315Hz output. If necessary, adjust RV81(L-CH), RV91(R-CH) and repeat the steps given above.

Adjustment Location : AUDIO board

Record Level Adjustment

Setting :

REC LEVEL control : standard record position (Refer to page 9.)

Procedure :

1. Record Mode

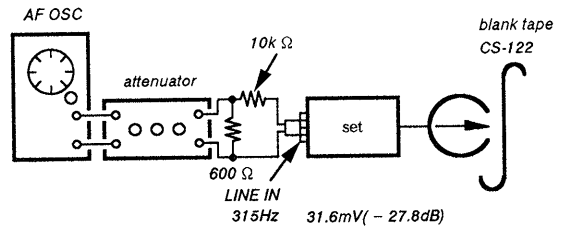

2. Playback Mode

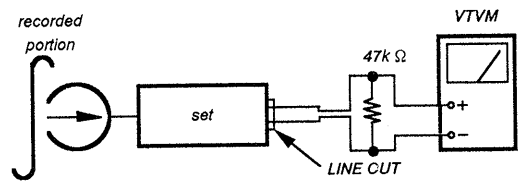

Confirm playback the tape recorded become adjustment level as follows.

If necessary, adjust RV101(L-CH), RV201(R-CH) and repeat the steps 1 and 2.

Adjustment Value :

LINE OUT level : $-27.7 \pm 0.5\text{dB}$ (30.2 to 33.8mV)

Adjustment Location : MAIN board

– Adjustment Parts Location Diagrams –

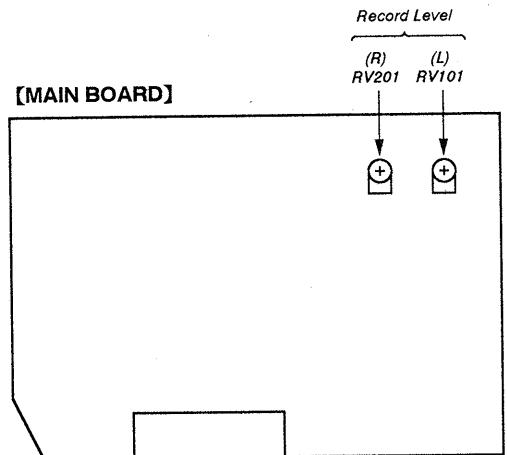

DECK A

[AUDIO BOARD]

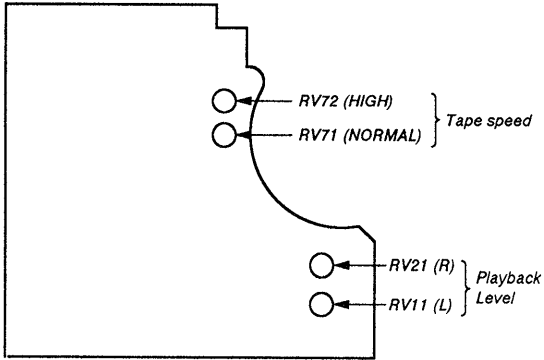

DECK B

[AUDIO BOARD]

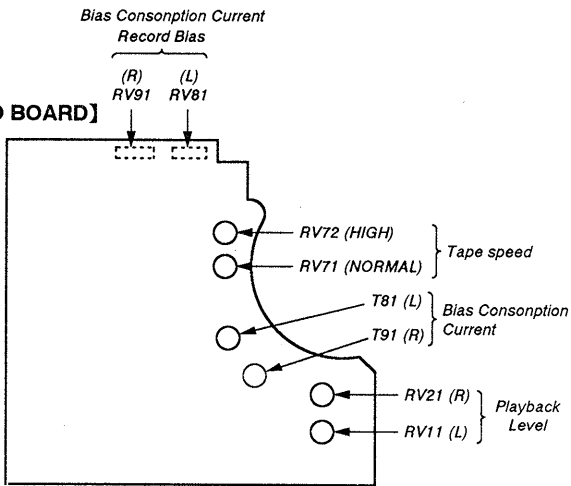

SECTION 5 DIAGRAMS

5-1. BLOCK DIAGRAM

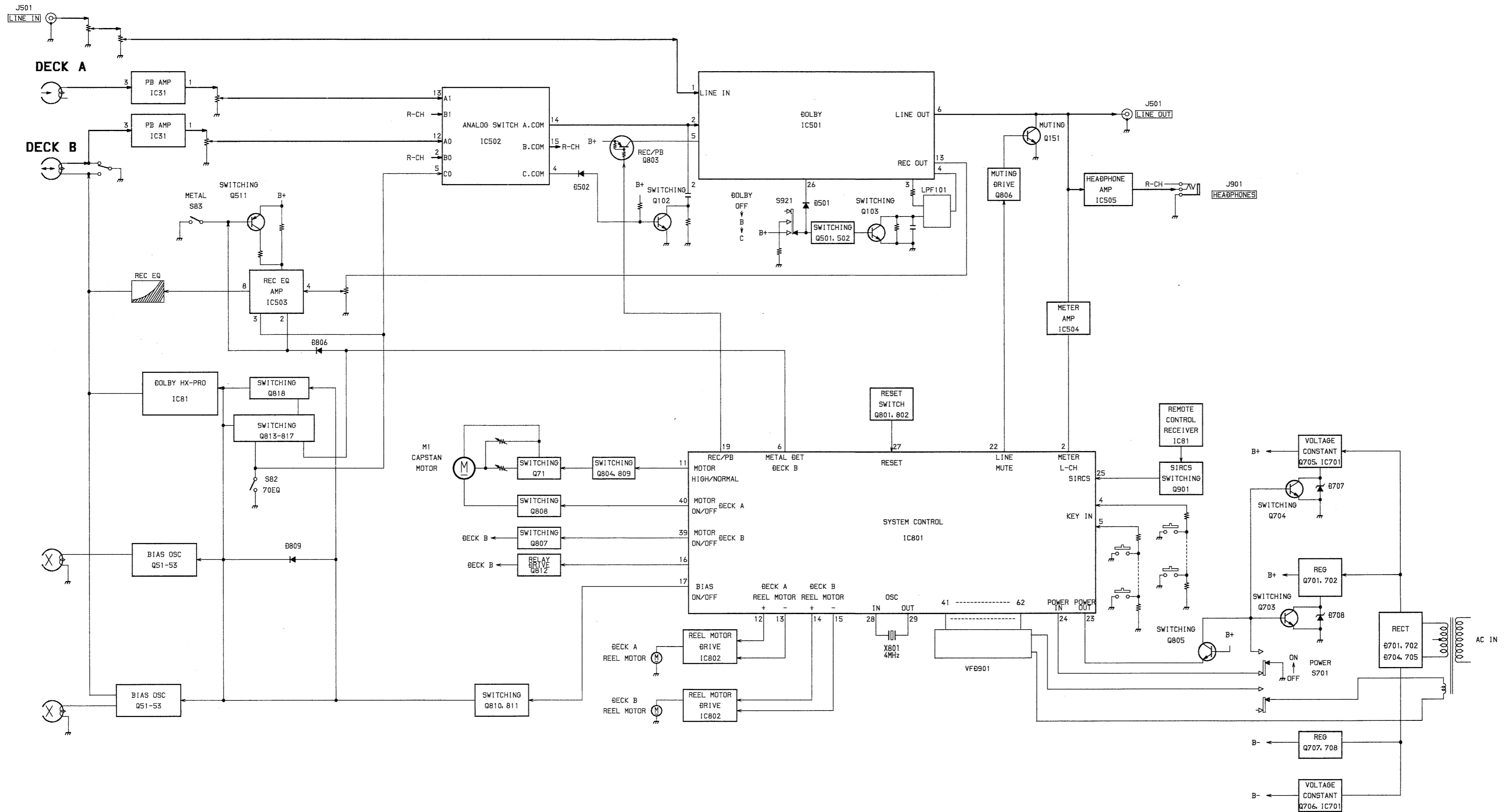

• SEMICONDUCTOR LEAD LAYOUTS.

CXA1331S

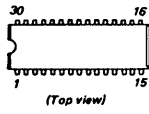

TA7272P

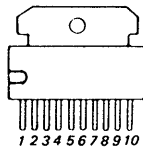

DTA114ES
DTC114ES
2SC2603-EF



HZS6A1L

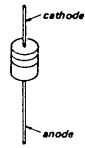

CXA1579P
MC14053

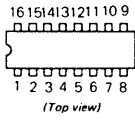

μ PC1297CA

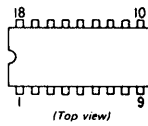

2SA1162



NJL5165K-B

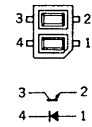

N50941-712SP

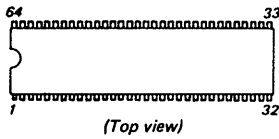

μ PC4570G2

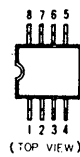

2SB1094-LK
2SD2012

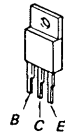

1N4148M
10E2N

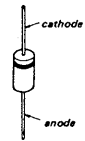

RC4558P

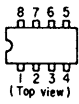

2SB1116A-L
2SD1387

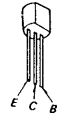

1SS355

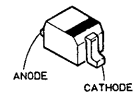

SBX1610-59

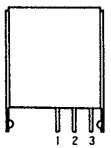

1 Vcc
2 Vout
3 GND

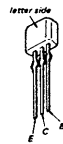

BN1L3Z-K
DTC114ES
DTC143TD
2SA1175-HFE

2SD1622-S

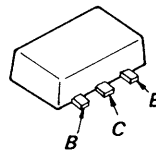

• SEMICONDUCTOR LOCATION

Ref. No.	Location	Ref. No.	Location
D151	F-21	Q102	G-23
D251	F-21	Q103	G-24
D501	G-21	Q151	D-21
D502	G-21	Q202	G-22
D701	D-16	Q203	G-22
D702	D-16	Q251	D-20
D703	D-15	Q501	G-22
D704	D-15	Q502	G-21
D705	D-16	Q701	D-18
D706	D-16	Q702	C-18
D707	D-15	Q703	D-17
D708	D-17	Q704	D-20
D709	D-20	Q705	C-19
D710	E-18	Q706	E-18
D711	E-16	Q707	E-16
D712	E-16	Q708	E-16
D713	E-17	Q801	E-17
D714	E-16	Q802	E-18
D802	H-15	Q803	F-18
D803	H-15	Q804	H-18
D804	G-20	Q805	F-18
D805	G-20	Q806	F-18
D806	H-20	Q807	H-18
D807	I-22	Q808	H-15
D808	H-18	Q809	H-18
D809	J-21	Q810	J-20
D810	E-18	Q811	J-20
		Q812	I-22
		Q813	I-21
IC501	F-23	Q814	I-21
IC502	G-21	Q815	I-21
IC503	D-23	Q816	I-21
IC504	F-21	Q817	I-20
IC505	E-21	Q818	J-21
IC701	D-19	Q901	G-8
IC801	F-17		
IC802	G-18		
IC901	G-8		

SW-A BOARD (DECK A)		SW-B BOARD (DECK B)	
Ref. No.	Location	Ref. No.	Location
IC81	C-5	IC81	H-32

AUDIO BOARD (DECK A)		AUDIO BOARD (DECK B)	
Ref. No.	Location	Ref. No.	Location
IC31	F-3	D31	H-25
Q71	F-5	IC81	H-27
		Q51	G-26
		Q52	G-26
		Q53	H-26
		Q71	H-28

Note:
 ○ : parts extracted from the component side.
 ● : parts extracted from the conductor side.
 [] : indicates side identified with part number.
 [] : Pattern on the side which is seen.
 [] : Pattern of the rear side.

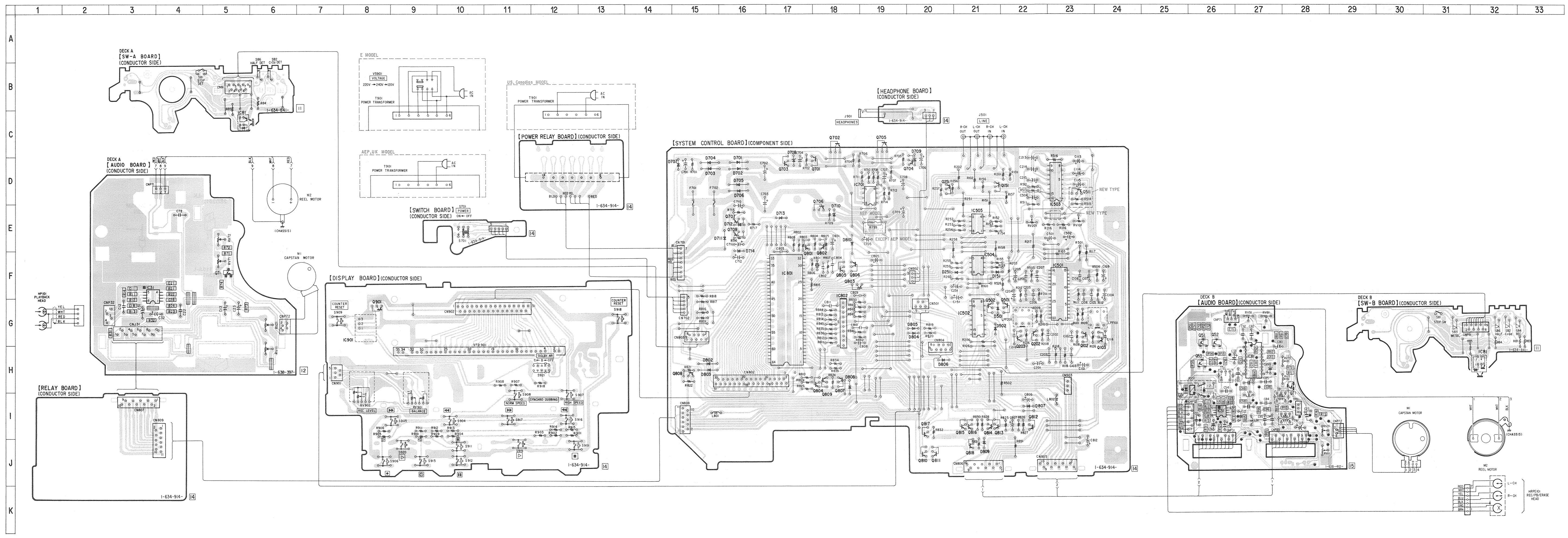

5-3. SCHEMATIC DIAGRAM (SYSTEM CONTROL SECTION)

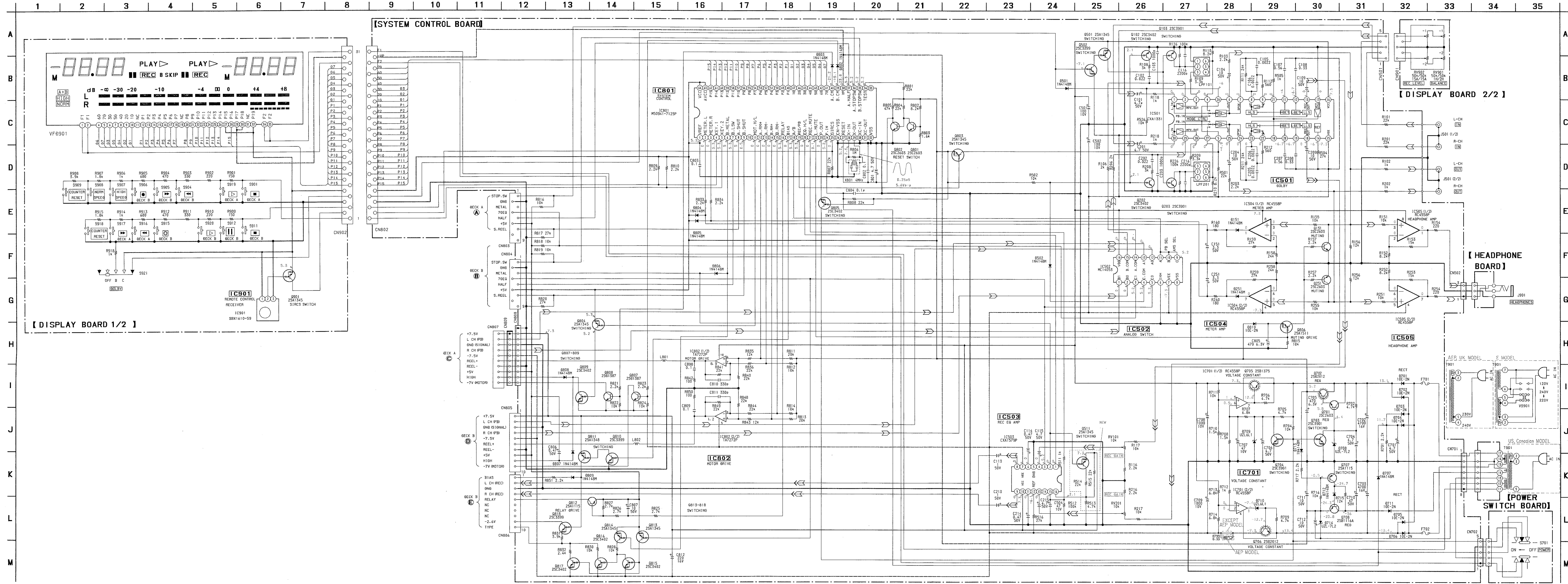

IC BLOCK DIAGRAM

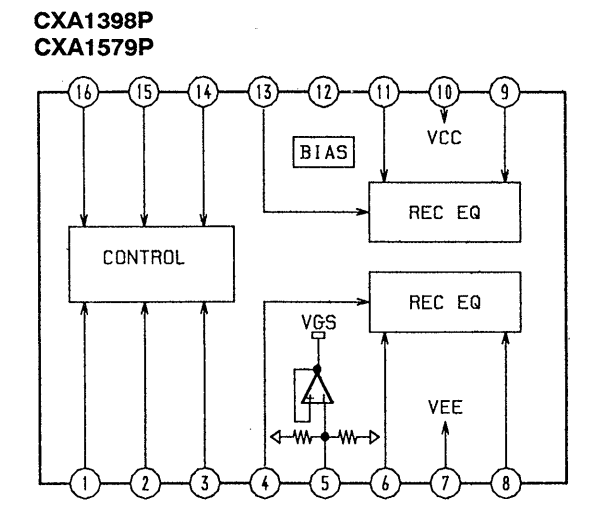

Note:

- All capacitors are in μF unless otherwise noted. pF : μF 50WV or less are not indicated except for electrolytics and tantalums.
- All resistors are in Ω and $\frac{1}{4}\text{W}$ or less unless otherwise specified.
- % : indicates tolerance.

Note:
The components identified by mark Δ or dotted line with mark Δ are critical for safety. Replace only with part number specified.

Note:
Les composants identifiés par une marque Δ sont critiques pour la sécurité. Ne les remplacer que par une pièce portant le numéro spécifié.

- --- : B+ Line
- --- : B- Line
- --- : adjustment for repair.
- Voltage and waveforms are dc with respect to ground under no-signal.
- no mark : STOP
- \odot : REC
- Voltages are taken with a VOM (input impedance 10M Ω). Voltage variations may be noted due to normal production tolerances.
- Signal path.
- --- : PB (DECK B)
- --- : PB (DECK A)
- --- : REC (DECK B)

5-4. SCHEMATIC DIAGRAM (AUDIO SECTION)

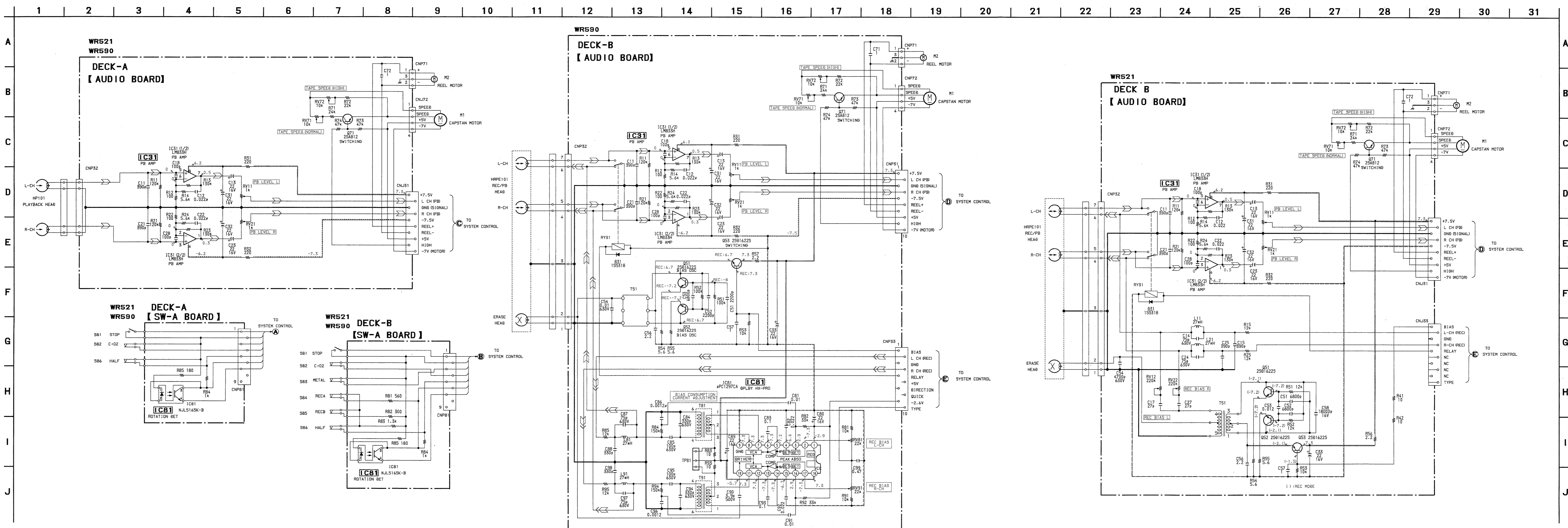

Note:

- All capacitors are in μF unless otherwise noted. $\text{pF} = \mu\text{F} \times 10^{-6}$ or less are not indicated except for electrolytics and tantalums.
- All resistors are in Ω and $\frac{1}{4}\text{W}$ or less unless otherwise specified.
- % : indicates tolerance.
- Δ : internal component.
- : B+ Line
- : B- Line
- : adjustment for repair.
- Voltage and waveforms are dc with respect to ground under no-signal.
- no mark : STOP
- ∇ : FWD
- \triangle : REV
- \odot : REC
- Volts are taken with a VOM (Input impedance $10\text{M}\Omega$). Voltage variations may be noted due to normal production tolerances.
- Signal path.
- \Rightarrow : PB (DECK A)
- \Rightarrow : REC (DECK B)

SECTION 6 EXPLODED VIEWS

NOTE:

- -XX, -X mean standardized parts, so they may have some differences from the original one.
- The construction parts of an assembled part are indicated with a collation number in the remark column.
- Color indication of Appearance Parts
Example:
KNOB, BALANCE (WHITE)....(RED)

- Items marked "*" are not stocked since they are seldom required for routine service. Some delay should be anticipated when ordering these items.
- The mechanical parts with no reference number in the exploded views are not supplied.
- Hardware (# mark) list is given in the last of this parts list.

The components identified by mark \triangle or dotted line with mark \triangle are critical for safety. Replace only with part number specified.

Les composants identifiés par une marque \triangle sont critiques pour la sécurité. Ne les remplacer que par une pièce portant le numéro spécifié.

Parts color ↑ Cabinet's color ↑
6-1. CHASSIS SECTION

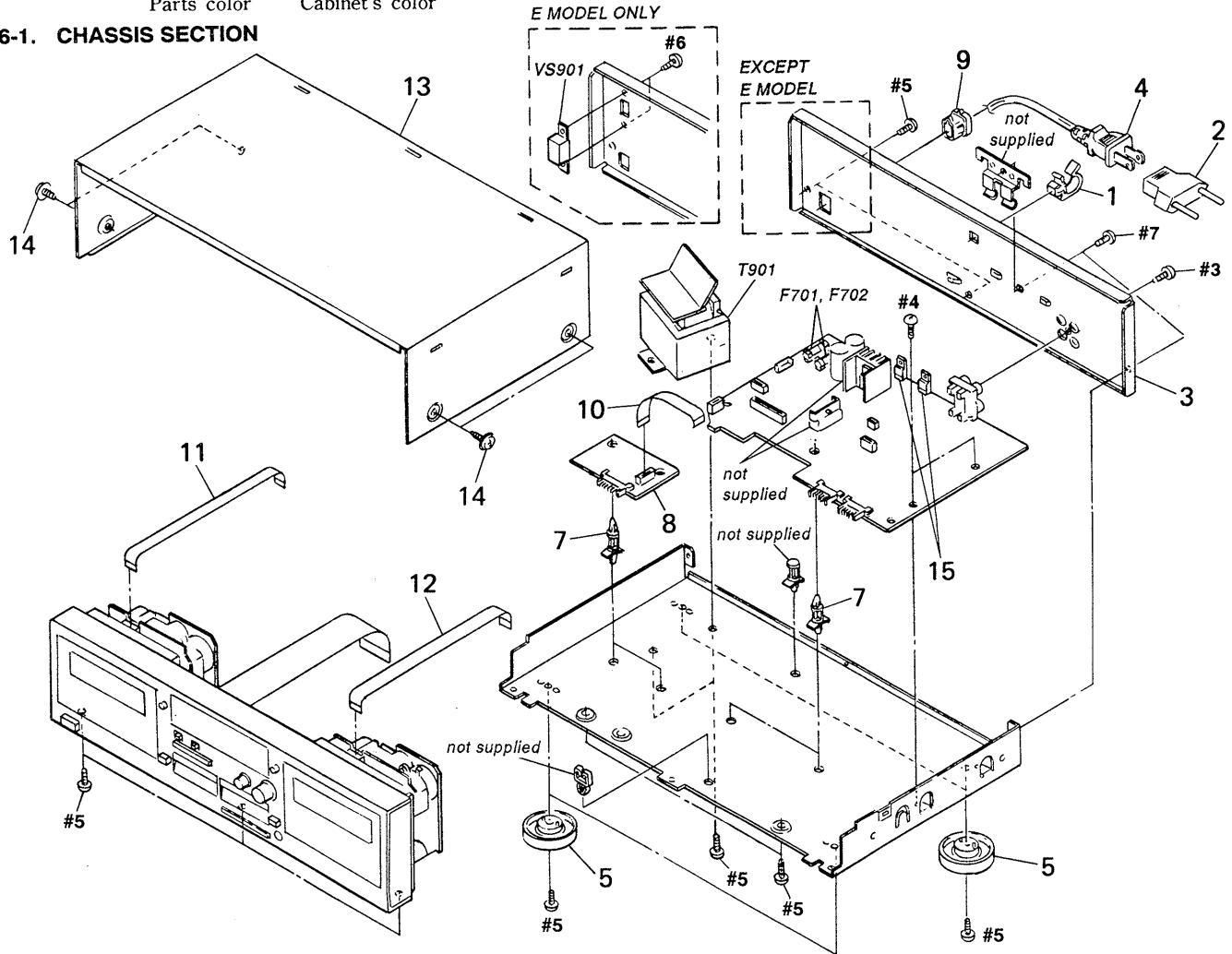

Ref. No.	Part No.	Description	Remark
* 1	4-949-235-01	HOOK	
\triangle 2	1-569-007-11	ADAPTER, CONVERSION 2P (E)	
* 3	3-377-350-01	PANEL, BACK (US, Canadian)	
* 3	3-377-350-21	PANEL, BACK (AEP)	
* 3	3-377-350-31	PANEL, BACK (UK)	
* 3	3-377-350-41	PANEL, BACK (E)	
\triangle 4	1-551-188-XX	CORD, POWER (E)	
\triangle 4	1-555-795-00	CORD, POWER, EULO PLUG (AEP)	
\triangle 4	1-556-035-00	CORD, POWER (UK)	
\triangle 4	1-558-945-11	CORD, POWER (POLAR. SPT-1) (US, Canadian)	
5	4-943-148-32	FOOT (F58175SW) (US, Canadian)	
* 7	3-346-265-11	HOLDER, PC BOARD	
* 8	A-2006-737-A	SYSTEM CONTROL BOARD, COMPLETE (US, Canadian, UK, E)	
* 8	A-2006-839-A	SYSTEM CONTROL BOARD, COMPLETE (AEP)	
* 9	3-703-244-00	BUSHING, CORD (AEP, UK)	
* 9	3-703-571-11	BUSHING (S), CORD (US, Canadian, E)	

Ref. No.	Part No.	Description	Remark
10	1-690-891-11	WIRE, FLAT TYPE (11 CORE)	
11	1-690-889-11	WIRE, FLAT TYPE (9 CORE)	
12	1-690-890-11	WIRE, FLAT TYPE (9 CORE)	
13	3-332-578-61	CASE	
14	3-704-366-01	SCREW (CASE) (M3X8)	
15	1-562-327-00	SOCKET, CONNECTOR 3P	
\triangle F701	1-532-285-00	FUSE (AEP, UK, E)	
\triangle F701	1-576-103-11	FUSE (US, Canadian)	
\triangle F702	1-532-285-00	FUSE (AEP, UK, E)	
\triangle F702	1-576-103-11	FUSE (US, Canadian)	
\triangle T901	1-450-837-11	TRANSFORMER, POWER (US, Canadian)	
\triangle T901	1-450-838-11	TRANSFORMER, POWER (AEP, UK)	
\triangle T901	1-450-839-11	TRANSFORMER, POWER (E)	
\triangle VS901	1-691-155-11	VOLTAGE SELECTOR (E)	

6-2. FRONT PANEL SECTION

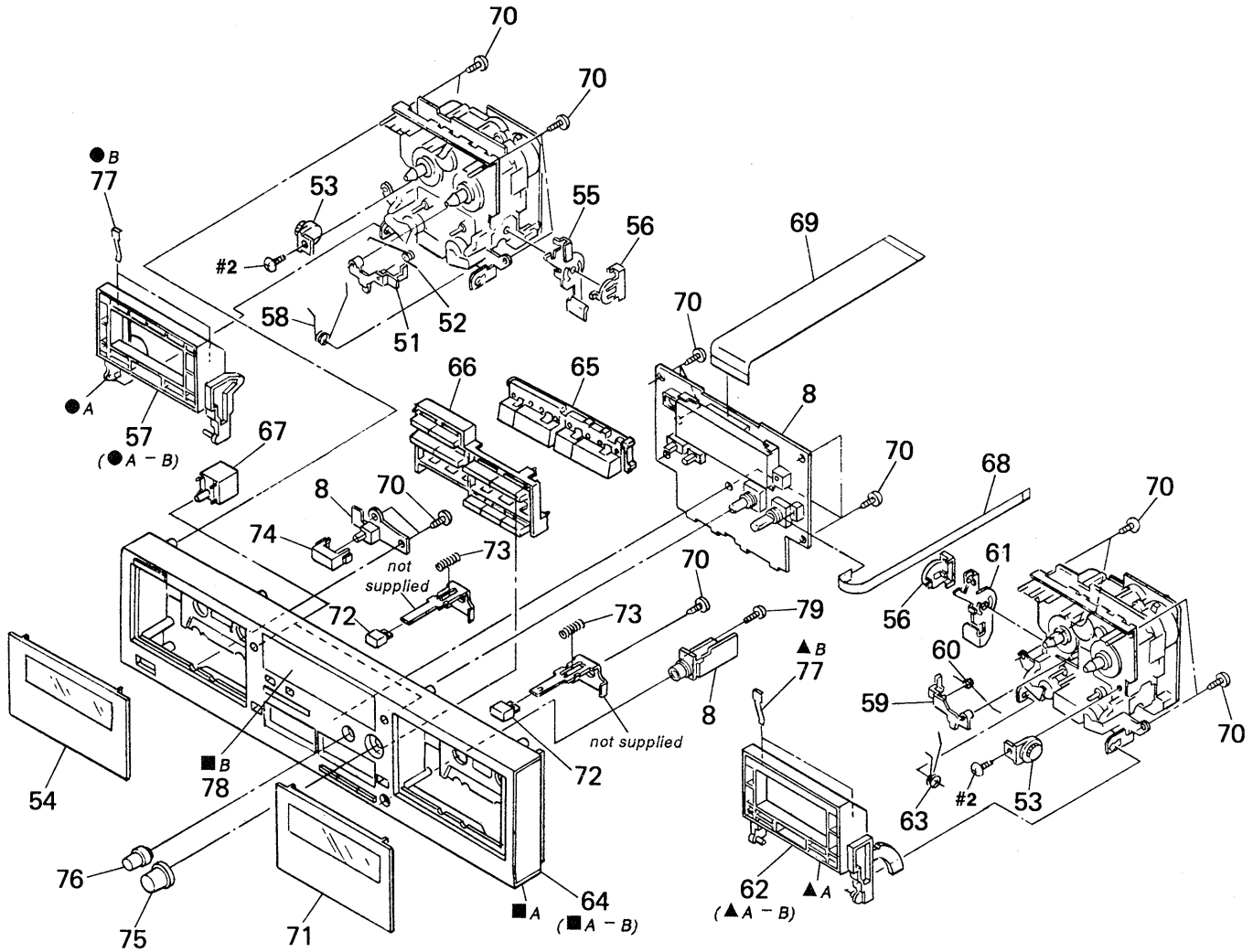

Ref. No.	Part No.	Description	Remark
51	3-354-956-01	LEVER (EJ SAFTY LEVER R)	
52	3-354-962-01	SPRING (EJ SAFTY SPRING R)	
53	3-354-963-01	DAMPER	
54	X-3364-742-1	LID (A) ASSY, CASSETTE	
* 55	3-354-954-01	LEVER (LOCK LEVER R)	
56	3-354-957-01	JOINT (LOCK LEVER)	
57	X-3340-195-1	HOLDER (R) ASSY, CASSETTE	
58	3-354-960-01	SPRING (LOADING R), TORSION	
59	3-354-955-01	LEVER (EJ SAFTY LEVER L)	
60	3-354-961-01	SPRING (EJ SAFTY SPRING L)	
* 61	3-354-953-01	LEVER (LOCK LEVER L)	
62	X-3340-194-1	HOLDER (L) ASSY, CASSETTE	
63	3-354-959-01	SPRING (LOADING L), TORSION	
64	X-3364-748-1	PANEL ASSY, FRONT (US, Canadian)	
64	X-3364-749-1	PANEL ASSY, FRONT (AEP, UK, E)	

Ref. No.	Part No.	Description	Remark
65	3-377-340-01	BUTTON (FW)	
66	3-377-341-01	BUTTON (SR)	
67	3-377-329-01	BUTTON (COUNTER)	
68	1-690-888-11	WIRE, FLAT TYPE (31 CORE)	
69	1-690-901-11	WIRE (FLAT TYPE) (5 CORE)	
70	4-951-620-11	SCREW +BVTP 2. 6X8	
71	X-3364-743-1	LID (B) ASSY, CASSETTE	
72	3-377-328-01	BUTTON (EJECT)	
73	3-359-906-01	SPRING, COMPRESSION	
74	3-354-932-01	BUTTON (POWER)	
75	3-377-334-01	KNOB (REC)	
76	3-367-431-01	KNOB (BAL)	
77	3-308-823-11	SPRING	
78	3-377-335-01	WINDOW (M)	
79	3-683-421-01	SCREW PTPWH 2. 6X8	

6-3. MECHANISM SECTION 1
(TCM-190VA12CS)
(TCM-190VB12CS)

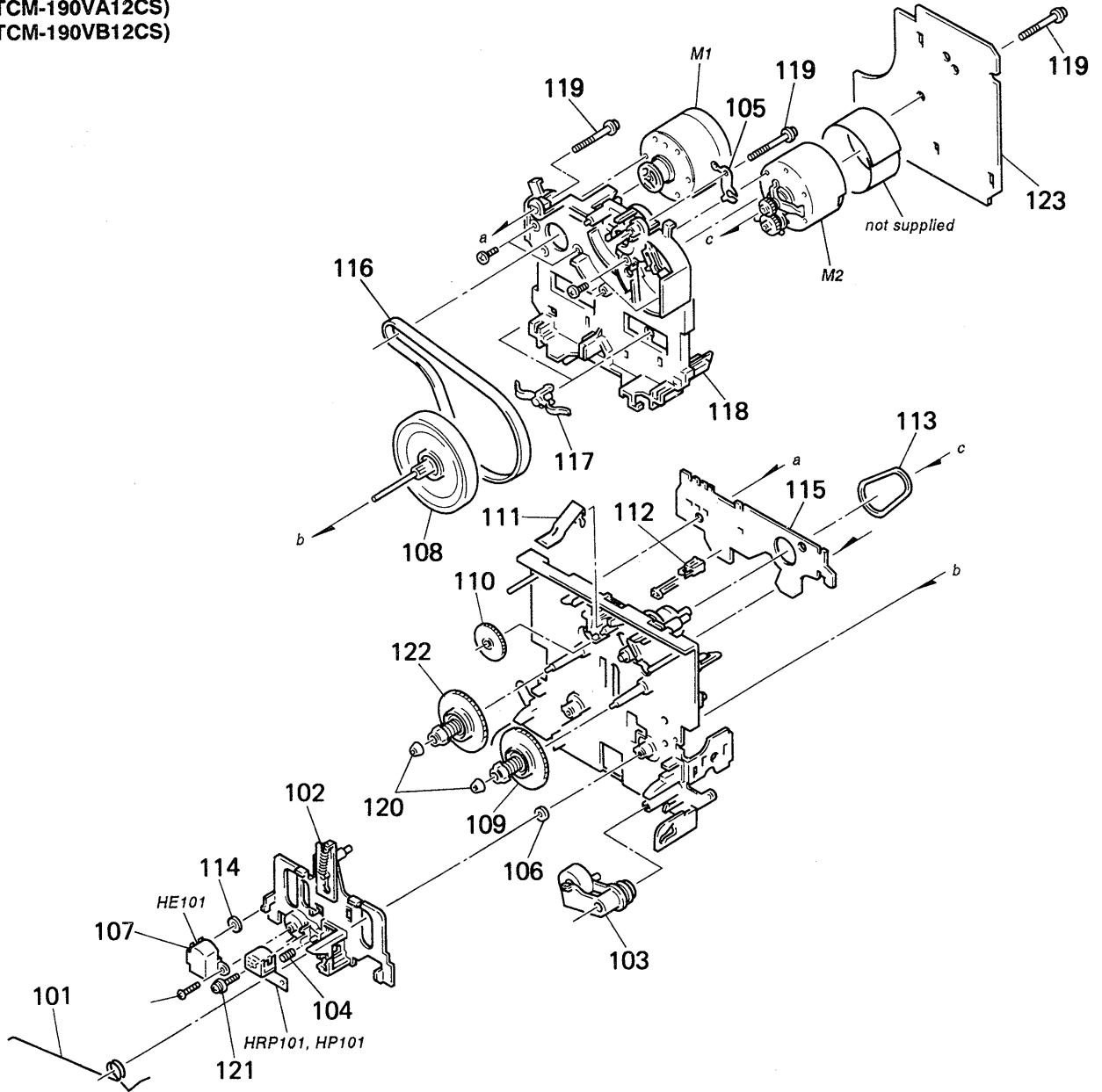

Ref. No.	Part No.	Description	Remark	Ref. No.	Part No.	Description	Remark
101	3-359-455-01	SPRING, TORSION		116	3-359-467-01	BELT (1 WAY FLAT BELT)	
102	3-363-868-01	SPRING (HEAD CHASSIS), TENSION		117	3-575-321-11	RETAINER, THRUST, CAPSTAN	
103	X-3359-408-1	LEVER (PINCH LEVER FWD) ASSY		* 118	3-359-436-01	BASE (THRUST RETAINER), FITTING	
104	3-343-484-01	SPRING, COMPRESSION		119	3-359-414-01	SCREW (+PTPWH 2X23)	
105	3-359-450-01	PLATE, GROUND		120	3-362-308-01	CAP (REEL)	
106	3-356-713-01	WASHER		121	3-359-446-01	SCREW (AZIMUTH ADJUSTMENT)	
107	3-319-716-01	GUIDE, TAPE (DECK A)		122	X-3362-078-1	TABLE ASSY (B), REEL	
108	X-3359-406-1	FLYWHEEL (FWD) COMPLETE ASSY		* 123	A-2006-755-A	AUDIO BOARD, COMPLETE (DECK A)	
109	X-3359-404-1	TABLE ASSY, REEL		* 123	A-2006-756-A	AUDIO BOARD, COMPLETE (DECK B)	
110	3-359-424-01	GEAR (REV GEAR)		HE101	1-543-673-11	HEAD, MAGNETIC (ERASE) (DECK B)	
111	3-359-430-01	SPRING (CASSETTE RETAINER), LEAF		HP101	1-543-920-11	HEAD, MAGNETIC (PLAYBACK) (DECK A)	
112	3-342-419-01	HOLDER (S SENSER A)		HRP101	1-543-919-11	HEAD, MAGNETIC (RECORD/PLAYBACK) (DECK B)	
113	3-359-466-01	BELT (FR) SQUARE		M1	X-3359-417-1	MOTOR ASSY, CAPSTAN	
114	3-359-364-01	WASHER (TAPE GUIDE)		M2	X-3363-501-1	MOTOR ASSY, REEL	
* 115	1-634-841-14	SW-A BOARD (DECK A)					

6-4. MECHANISM SECTION 2

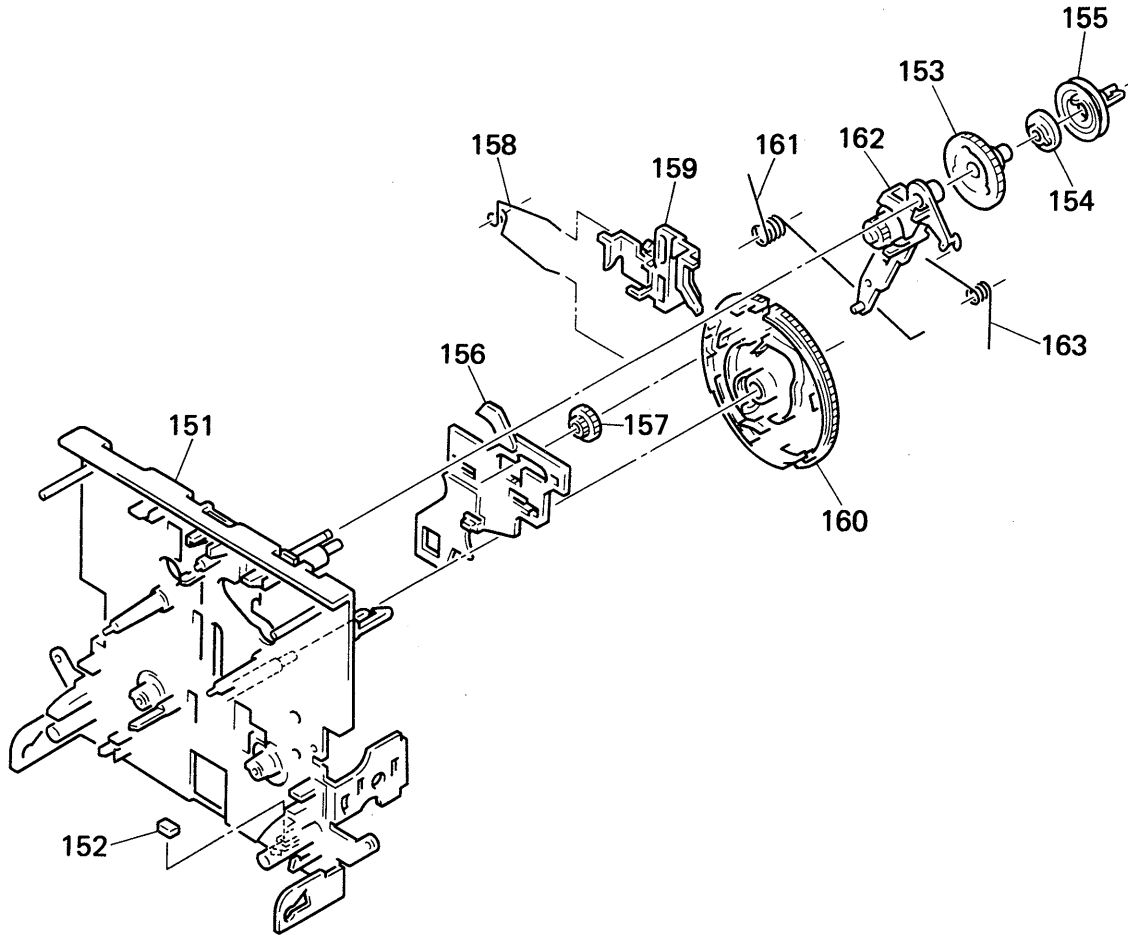

Ref. No.	Part No.	Description	Remark
151	X-3359-416-1	CHASSIS (ONE) ASSY, MECHANICAL	
152	3-359-469-01	SPACER	
153	3-359-419-01	GEAR (FR GEAR)	
154	3-359-421-01	CLUTCH (REEL DISK)	
155	3-359-418-01	PULLEY (FR PULLEY)	
* 156	3-359-415-01	SLIDER (TRIGGER SLIDER)	
157	3-359-448-01	GEAR (TRIGGER)	

Ref. No.	Part No.	Description	Remark
158	3-359-454-01	SPRING, TORSION	
159	3-359-429-01	SLIDER (BRAKE PLATE)	
160	3-359-420-01	GEAR (CAM GEAR)	
161	3-359-456-01	SPRING (TRIGGER SPRING), TORSION	
162	X-3359-405-1	LEVER (FR ARM) ASSY	
163	3-359-453-01	SPRING (FR ARM), TORSION	

SECTION 7
ELECTRICAL PARTS LIST

AUDIO (DECK A)

AUDIO (DECK B)

NOTE:

- Due to standardization, replacements in the parts list may be different from the parts specified in the diagrams or the components used on the set.
- -XX, -X mean standardized parts, so they may have some difference from the original one.
- RESISTORS
All resistors are in ohms
METAL: Metal-film resistor
METAL OXIDE: Metal oxide-film resistor
F: nonflammable

- Items marked "*" are not stocked since they are seldom required for routine service. Some delay should be anticipated when ordering these items.
- SEMICONDUCTORS
In each case, u:μ, for example:
uA.....:μA....., uPA.....:μPA.....
uPB.....:μPB....., uPC.....:μPC.....
uPD.....:μPD.....
- CAPACITORS
uF:μF
- COILS
uH:μH

The components identified by mark Δ or dotted line with mark Δ are critical for safety. Replace only with part number specified.

Les composants identifiés par une marque Δ sont critiques pour la sécurité. Ne les remplacer que par une pièce portant le numéro spécifié.

When indicating parts by reference number, please include the board.

Ref. No.	Part No.	Description	Remark		
*	A-2006-755-A	AUDIO BOARD, COMPLETE (DECK A)	*****		
		< CAPACITOR >			
C11	1-163-133-00	CERAMIC CHIP	470PF	5%	50V
C12	1-136-157-00	FILM	0.022uF	5%	50V
C13	1-124-234-00	ELECT	22uF	20%	16V
C18	1-163-117-00	CERAMIC CHIP	100PF	5%	50V
C21	1-163-133-00	CERAMIC CHIP	470PF	5%	50V
C22	1-136-157-00	FILM	0.022uF	5%	50V
C23	1-124-234-00	ELECT	22uF	20%	16V
C28	1-163-117-00	CERAMIC CHIP	100PF	5%	50V
C31	1-124-234-00	ELECT	22uF	20%	16V
C32	1-124-234-00	ELECT	22uF	20%	16V
C72	1-124-499-11	ELECT, NONPOLAR	1uF	20%	50V
		< CONNECTOR >			
* CNJ31	1-580-782-11	CONNECTOR, BOARD TO BOARD			
* CNJ72	1-580-411-11	SOCKET, CONNECTOR 4P			
* CNP32	1-580-772-11	PIN, CONNECTOR (PC BOARD) 4P			
* CNP71	1-564-719-11	PIN, CONNECTOR (SMALL TYPE) 3P			
		< IC >			
IC31	8-759-106-02	IC	uPC4570G2		
		< JUMPER >			
JW1	1-216-295-00	METAL CHIP	0	5%	1/10W
JW51	1-216-296-00	METAL CHIP	0	5%	1/8W
JW52	1-216-296-00	METAL CHIP	0	5%	1/8W
JW53	1-216-296-00	METAL CHIP	0	5%	1/8W
JW54	1-216-296-00	METAL CHIP	0	5%	1/8W
		< TRANSISTOR >			
Q71	8-729-602-36	TRANSISTOR	2SA1602		

Ref. No.	Part No.	Description	Remark		
		< RESISTOR >			
R11	1-216-107-00	METAL CHIP	270K	5%	1/10W
R12	1-216-025-00	METAL CHIP	100	5%	1/10W
R13	1-216-100-00	METAL GLAZE	130K	5%	1/10W
R14	1-216-067-00	METAL CHIP	5.6K	5%	1/10W
R21	1-216-107-00	METAL CHIP	270K	5%	1/10W
R22	1-216-025-00	METAL CHIP	100	5%	1/10W
R23	1-216-100-00	METAL GLAZE	130K	5%	1/10W
R24	1-216-067-00	METAL CHIP	5.6K	5%	1/10W
R31	1-216-033-00	METAL CHIP	220	5%	1/10W
R32	1-216-033-00	METAL CHIP	220	5%	1/10W
R71	1-216-082-00	METAL GLAZE	24K	5%	1/10W
R72	1-216-081-00	METAL CHIP	22K	5%	1/10W
R73	1-216-089-00	METAL CHIP	47K	5%	1/10W
R74	1-216-089-00	METAL CHIP	47K	5%	1/10W
		< VARIABLE RESISTOR >			
RV11	1-238-012-11	RES, ADJ, CARBON	1K		
RV21	1-238-012-11	RES, ADJ, CARBON	1K		
RV71	1-238-016-11	RES, ADJ, CARBON	10K		
RV72	1-238-016-11	RES, ADJ, CARBON	10K		

* A-2006-756-A AUDIO BOARD, COMPLETE (DECK B)

Ref. No.	Part No.	Description	Remark		
		< CAPACITOR >			
C11	1-163-133-00	CERAMIC CHIP	470PF	5%	50V
C12	1-136-157-00	FILM	0.022uF	5%	50V
C13	1-124-234-00	ELECT	22uF	20%	16V
C18	1-163-117-00	CERAMIC CHIP	100PF	5%	50V
C21	1-163-133-00	CERAMIC CHIP	470PF	5%	50V

AUDIO (DECK B)

Ref. No.	Part No.	Description	Remark	Ref. No.	Part No.	Description	Remark
C22	1-136-157-00	FILM	0.022uF 5% 50V			< COIL >	
C23	1-124-234-00	ELECT	22uF 20% 16V				
C28	1-163-117-00	CERAMIC CHIP	100PF 5% 50V	L81	1-410-780-11	INDUCTOR 27mH	
C31	1-124-234-00	ELECT	22uF 20% 16V	L91	1-410-780-11	INDUCTOR 27mH	
C32	1-124-234-00	ELECT	22uF 20% 16V			< TRANSISTOR >	
C33	1-124-234-00	ELECT	22uF 20% 16V	Q51	8-729-808-01	TRANSISTOR 2SD1622-S	
C51	1-164-182-11	CERAMIC CHIP	0.0033uF 10% 50V	Q52	8-729-808-01	TRANSISTOR 2SD1622-S	
C52	1-164-182-11	CERAMIC CHIP	0.0033uF 10% 50V	Q53	8-729-808-01	TRANSISTOR 2SD1622-S	
C53	1-163-020-00	CERAMIC CHIP	0.0082uF 10% 50V	Q71	8-729-216-22	TRANSISTOR 2SA1162	
C54	1-136-601-11	FILM	0.01uF 5% 630V			< RESISTOR >	
C56	1-164-505-11	CERAMIC CHIP	2.2uF 16V				
C57	1-164-346-11	CERAMIC CHIP	1uF 16V	R11	1-216-107-00	METAL CHIP 270K 5% 1/10W	
C71	1-164-346-11	CERAMIC CHIP	1uF 16V	R12	1-216-025-00	METAL CHIP 100 5% 1/10W	
C80	1-124-234-00	ELECT	22uF 20% 16V	R13	1-216-100-00	METAL GLAZE 130K 5% 1/10W	
C81	1-164-232-11	CERAMIC CHIP	0.01uF 50V	R14	1-216-067-00	METAL CHIP 5.6K 5% 1/10W	
C82	1-136-157-00	FILM	0.022uF 5% 50V	R21	1-216-107-00	METAL CHIP 270K 5% 1/10W	
C83	1-164-004-11	CERAMIC CHIP	0.1uF 10% 25V	R22	1-216-025-00	METAL CHIP 100 5% 1/10W	
C84	1-136-478-11	FILM	470PF 5% 630V	R23	1-216-100-00	METAL GLAZE 130K 5% 1/10W	
C85	1-136-433-11	FILM	100PF 5% 630V	R24	1-216-067-00	METAL CHIP 5.6K 5% 1/10W	
C86	1-163-143-00	CERAMIC CHIP	0.0012uF 5% 50V	R31	1-216-033-00	METAL CHIP 220 5% 1/10W	
C87	1-136-273-91	FILM	75PF 5% 630V	R32	1-216-033-00	METAL CHIP 220 5% 1/10W	
C88	1-163-003-11	CERAMIC CHIP	330PF 10% 50V	R51	1-216-091-00	METAL CHIP 56K 5% 1/10W	
C89	1-124-234-00	ELECT	22uF 20% 16V	R52	1-216-091-00	METAL CHIP 56K 5% 1/10W	
C90	1-107-045-00	MICA	3.9PF 500V	R53	1-216-073-00	METAL CHIP 10K 5% 1/10W	
C91	1-164-232-11	CERAMIC CHIP	0.01uF 50V	R54	1-216-309-00	METAL CHIP 5.6 5% 1/10W	
C92	1-136-157-00	FILM	0.022uF 5% 50V	R55	1-216-309-00	METAL CHIP 5.6 5% 1/10W	
C93	1-164-004-11	CERAMIC CHIP	0.1uF 10% 25V	R57	1-216-298-00	METAL CHIP 2.2 5% 1/10W	
C94	1-136-478-11	FILM	470PF 5% 630V	R71	1-216-082-00	METAL GLAZE 24K 5% 1/10W	
C95	1-136-433-11	FILM	100PF 5% 630V	R72	1-216-081-00	METAL CHIP 22K 5% 1/10W	
C96	1-163-143-00	CERAMIC CHIP	0.0012uF 5% 50V	R73	1-216-089-00	METAL CHIP 47K 5% 1/10W	
C97	1-136-273-91	FILM	75PF 5% 630V	R74	1-216-089-00	METAL CHIP 47K 5% 1/10W	
C98	1-163-003-11	CERAMIC CHIP	330PF 10% 50V	R81	1-216-073-00	METAL CHIP 10K 5% 1/10W	
C99	1-164-005-11	CERAMIC CHIP	0.47uF 25V	R82	1-216-085-00	METAL CHIP 33K 5% 1/10W	
		< CONNECTOR >		R83	1-216-001-00	METAL CHIP 10 5% 1/10W	
* CNP31	1-580-782-11	CONNECTOR, BOARD TO BOARD		R84	1-216-101-00	METAL CHIP 150K 5% 1/10W	
* CNP32	1-580-781-11	PIN, CONNECTOR (PC BOARD) 7P		R85	1-216-075-00	METAL CHIP 12K 5% 1/10W	
* CNP33	1-580-782-11	CONNECTOR, BOARD TO BOARD		R91	1-216-073-00	METAL CHIP 10K 5% 1/10W	
* CNP71	1-564-719-11	PIN, CONNECTOR (SMALL TYPE) 3P		R92	1-216-085-00	METAL CHIP 33K 5% 1/10W	
* CNP72	1-580-411-11	SOCKET, CONNECTOR 4P		R93	1-216-001-00	METAL CHIP 10 5% 1/10W	
		< DIODE >		R94	1-216-101-00	METAL CHIP 150K 5% 1/10W	
D31	8-719-988-62	DIODE 1SS355		R95	1-216-075-00	METAL CHIP 12K 5% 1/10W	
		< IC >				< VARIABLE RESISTOR >	
IC31	8-759-106-02	IC uPC4570G2		RV11	1-238-012-11	RES, ADJ, CARBON 1K	
IC81	8-759-106-56	IC uPC1297CA		RV21	1-238-012-11	RES, ADJ, CARBON 1K	
				RV71	1-238-016-11	RES, ADJ, CARBON 10K	
				RV72	1-238-016-11	RES, ADJ, CARBON 10K	
				RV81	1-241-122-11	RES, ADJ, CARBON 22K	
				RV91	1-241-122-11	RES, ADJ, CARBON 22K	

AUDIO (DECK B)

SW-A (DECK A)

SW-A (DECK B)

SYSTEM CONTROL

Ref. No.	Part No.	Description	Remark
		< RELAY >	
RY31	1-515-726-11	RELAY	
		< TRANSFORMER >	
T81	1-433-381-11	TRANSFORMER, BIAS OSCILLATOR	
T91	1-433-381-11	TRANSFORMER, BIAS OSCILLATOR	
		< TEST PIN >	
* TP81	1-568-449-11	HOUSING, CONNECTOR (PC BOARD) 3P	

*	1-634-841-14	SW-A BOARD (DECK A)	

	3-343-419-01	HOLDER (S SENSER A)	
		< CONNECTOR >	
* CNP81	1-568-852-11	SOCKET, CONNECTOR 9P	
		< IC >	
IC81	8-719-710-03	DIODE NJL5165K-B	
		< RESISTOR >	
R84	1-249-417-11	CARBON 1K 5% 1/4W	
R85	1-249-408-11	CARBON 180 5% 1/4W	
		< SWITCH >	
S81	1-571-958-11	SWITCH, PUSH (STOP)	
S82	1-571-281-21	SWITCH, LEAF (CrO2)	
S86	1-571-281-21	SWITCH, LEAF (HALF)	

*	1-634-841-14	SW-A BOARD (DECK B)	

	3-343-419-01	HOLDER (S SENSER A)	
		< CONNECTOR >	
* CNP81	1-568-852-11	SOCKET, CONNECTOR 9P	
		< IC >	
IC81	8-719-710-03	DIODE NJL5165K-B	

Ref. No.	Part No.	Description	Remark
		< RESISTOR >	
R81	1-249-414-11	CARBON 560 5% 1/4W	
R83	1-247-834-11	CARBON 1.3K 5% 1/4W	
R84	1-249-417-11	CARBON 1K 5% 1/4W	
R85	1-249-408-11	CARBON 180 5% 1/4W	
		< SWITCH >	
S81	1-571-958-11	SWITCH, PUSH (STOP)	
S82	1-571-281-21	SWITCH, LEAF (CrO2)	
S83	1-571-281-21	SWITCH, LEAF (METAL)	
S84	1-571-281-21	SWITCH, LEAF (REC A)	
S86	1-571-281-21	SWITCH, LEAF (HALF)	

*	A-2006-737-A	SYSTEM CONTROL BOARD, COMPLETE (US, Canadian, UK, E)	
*	A-2006-839-A	SYSTEM CONTROL BOARD, COMPLETE (AEP)	

*	1-533-213-31	HOLDER, FUSE	
*	1-562-327-00	SOCKET, CONNECTOR 3P	
	7-685-646-79	SCREW +BVTP 3X8 TYPE2 IT-3	
	7-682-547-04	SCREW +BVTT 3X6 (S)	
		< CAPACITOR >	
C101	1-124-927-11	ELECT 4.7uF 20% 100V	
C102	1-136-157-00	FILM 0.022uF 5% 50V	
C103	1-162-294-31	CERAMIC 0.001uF 10% 50V	
C104	1-124-907-11	ELECT 10uF 20% 50V	
C105	1-130-475-00	MYLAR 0.0022uF 5% 50V	
C106	1-130-475-00	MYLAR 0.0022uF 5% 50V	
C107	1-136-174-00	FILM 0.56uF 5% 50V	
C108	1-136-171-00	FILM 0.33uF 5% 50V	
C109	1-124-907-11	ELECT 10uF 20% 50V	
C113	1-124-903-11	ELECT 1uF 20% 50V	
C114	1-124-902-00	ELECT 0.47uF 20% 50V	
C115	1-124-927-11	ELECT 4.7uF 20% 100V	
C116	1-161-375-00	CERAMIC 0.0022uF 20% 50V	
C151	1-123-382-00	ELECT 3.3uF 20% 100V	
C201	1-124-927-11	ELECT 4.7uF 20% 100V	
C202	1-136-157-00	FILM 0.022uF 5% 50V	
C203	1-162-294-31	CERAMIC 0.001uF 10% 50V	
C204	1-124-907-11	ELECT 10uF 20% 50V	
C205	1-130-475-00	MYLAR 0.0022uF 5% 50V	
C206	1-130-475-00	MYLAR 0.0022uF 5% 50V	
C207	1-136-174-00	FILM 0.56uF 5% 50V	
C208	1-136-171-00	FILM 0.33uF 5% 50V	
C209	1-124-907-11	ELECT 10uF 20% 50V	
C213	1-124-903-11	ELECT 1uF 20% 50V	
C214	1-124-902-00	ELECT 0.47uF 20% 50V	

SYSTEM CONTROL

Ref. No.	Part No.	Description	Remark	Ref. No.	Part No.	Description	Remark
C215	1-124-927-11	ELECT	4. 7uF 20% 100V			< DIODE >	
C216	1-161-375-00	CERAMIC	0. 0022uF 20% 50V				
C251	1-123-382-00	ELECT	3. 3uF 20% 100V				
C501	1-124-443-00	ELECT	100uF 20% 10V	D151	8-719-987-63	DIODE 1N4148M	
C502	1-124-443-00	ELECT	100uF 20% 10V	D251	8-719-987-63	DIODE 1N4148M	
C504	1-124-126-00	ELECT	47uF 20% 10V	D501	8-719-987-63	DIODE 1N4148M	
C701	1-124-927-11	ELECT	4. 7uF 20% 100V	D502	8-719-987-63	DIODE 1N4148M	
C702	1-124-898-11	ELECT	4700uF 20% 16V	D701	8-719-200-77	DIODE 10E2N	
C703	1-124-898-11	ELECT	4700uF 20% 16V	D702	8-719-200-77	DIODE 10E2N	
C704	1-124-927-11	ELECT	4. 7uF 20% 100V	D703	8-719-200-77	DIODE 10E2N	
C705	1-124-472-11	ELECT	470uF 20% 10V	D704	8-719-200-77	DIODE 10E2N	
C706	1-124-927-11	ELECT	4. 7uF 20% 100V	D705	8-719-200-77	DIODE 10E2N	
C707	1-124-126-00	ELECT	47uF 20% 10V	D706	8-719-200-77	DIODE 10E2N	
C708	1-124-473-11	ELECT	1000uF 20% 10V	D707	8-719-987-63	DIODE 1N4148M	
C709	1-124-473-11	ELECT	1000uF 20% 10V	D708	8-719-000-78	DIODE HZS7A1L	
C710	1-124-910-11	ELECT	47uF 20% 50V	D709	8-719-933-33	DIODE HZS6A1L	
C711	1-124-907-11	ELECT	10uF 20% 50V	D710	8-719-933-33	DIODE HZS6A1L	
C712	1-124-907-11	ELECT	10uF 20% 50V	D711	8-719-200-77	DIODE 10E2N	
C801	1-124-927-11	ELECT	4. 7uF 20% 100V	D712	8-719-987-63	DIODE 1N4148M	
C802	1-164-159-11	CERAMIC	0. 1uF 50V	D713	8-719-987-63	DIODE 1N4148M	
C803	1-164-159-11	CERAMIC	0. 1uF 50V	D714	8-719-000-78	DIODE HZS7A1L	
C804	1-164-159-11	CERAMIC	0. 1uF 50V	D802	8-719-987-63	DIODE 1N4148M	
C805	1-124-472-11	ELECT	470uF 20% 10V	D803	8-719-987-63	DIODE 1N4148M	
C806	1-124-902-00	ELECT	0. 47uF 20% 50V	D804	8-719-987-63	DIODE 1N4148M	
C807	1-124-907-11	ELECT	10uF 20% 50V	D805	8-719-987-63	DIODE 1N4148M	
C808	1-136-165-00	FILM	0. 1uF 5% 50V	D806	8-719-987-63	DIODE 1N4148M	
C809	1-136-165-00	FILM	0. 1uF 5% 50V	D807	8-719-987-63	DIODE 1N4148M	
C810	1-162-288-31	CERAMIC	330PF 10% 50V	D808	8-719-987-63	DIODE 1N4148M	
C811	1-162-288-31	CERAMIC	330PF 10% 50V	D809	8-719-987-63	DIODE 1N4148M	
C812	1-124-120-11	ELECT	220uF 20% 25V	D810	8-719-200-77	DIODE 10E2N	
		< CONNECTOR >				< IC >	
* CN501	1-568-824-11	SOCKET, CONNECTOR 5P		IC501	8-752-059-55	IC CXA1331S	
CN502	1-506-468-11	CONNECTOR 3P, MALE		IC502	8-759-140-53	IC MC14053BCP	
* CN503	1-564-506-11	PLUG, CONNECTOR 3P		IC503	8-752-055-62	IC CXA1579P	
* CN701	1-564-510-11	PLUG, CONNECTOR 7P		IC504	8-759-945-58	IC RC4558P	
* CN702	1-568-954-11	PIN, CONNECTOR 5P		IC505	8-759-945-58	IC RC4558P	
* CN802	1-568-845-11	SOCKET, CONNECTOR 31P		IC701	8-759-945-58	IC RC4558P	
* CN803	1-568-828-11	SOCKET, CONNECTOR 9P		IC801	8-759-062-38	IC M50941-712SP	
* CN804	1-568-828-11	SOCKET, CONNECTOR 9P		IC802	8-759-207-05	IC TA7272P	
CN805	1-691-916-11	CONNECTOR, BOARD TO BOARD		IC901	8-741-100-48	IC SBX1610-59	
CN806	1-691-916-11	CONNECTOR, BOARD TO BOARD				< JACK >	
CN807	1-691-916-11	CONNECTOR, BOARD TO BOARD		J501	1-565-258-11	JACK, PIN 4P (LINE)	
* CN808	1-568-830-11	SOCKET, CONNECTOR 11P		J901	1-507-796-71	JACK (HEADPHONES)	
* CN809	1-568-830-11	SOCKET, CONNECTOR 11P				< COIL >	
* CN901	1-568-824-11	SOCKET, CONNECTOR 5P		* L801	1-420-872-00	COIL, AIR CORE	
* CN902	1-568-873-11	SOCKET, CONNECTOR 31P		* L802	1-420-872-00	COIL, AIR CORE	

SYSTEM CONTROL

Ref. No.	Part No.	Description	Remark	Ref. No.	Part No.	Description	Remark
		< FILTER >					
LPF101	1-231-388-00	FILTER, LOW PASS		R109	1-249-423-11	CARBON 3.3K 5% 1/4W	
LPF201	1-231-388-00	FILTER, LOW PASS		R110	1-249-428-11	CARBON 8.2K 5% 1/4W	
		< TRANSISTOR >		R111	1-247-864-11	CARBON 24K 5% 1/4W	
Q102	8-729-900-80	TRANSISTOR DTC114ES		R112	1-249-414-11	CARBON 560 5% 1/4W	
Q103	8-729-900-74	TRANSISTOR DTC143TS		R116	1-249-421-11	CARBON 2.2K 5% 1/4W	
Q151	8-729-620-05	TRANSISTOR 2SC2603-EF					
Q202	8-729-900-80	TRANSISTOR DTC114ES		R117	1-249-429-11	CARBON 10K 5% 1/4W	
Q203	8-729-900-74	TRANSISTOR DTC143TS		R118	1-249-417-11	CARBON 1K 5% 1/4W	
				R126	1-249-441-11	CARBON 100K 5% 1/4W	
Q251	8-729-620-05	TRANSISTOR 2SC2603-EF		R151	1-249-429-11	CARBON 10K 5% 1/4W	
Q501	8-729-900-65	TRANSISTOR DTA144ES		R152	1-249-428-11	CARBON 8.2K 5% 1/4W	
Q502	8-729-900-89	TRANSISTOR DTC144ES					
Q511	8-729-900-65	TRANSISTOR DTA144ES (NEW)		R153	1-249-431-11	CARBON 15K 5% 1/4W	
Q701	8-729-620-05	TRANSISTOR 2SC2603-EF		R154	1-249-409-11	CARBON 220 5% 1/4W	
Q702	8-729-209-15	TRANSISTOR 2SD2012		R155	1-249-429-11	CARBON 10K 5% 1/4W	
				R156	1-249-430-11	CARBON 12K 5% 1/4W	
Q703	8-729-900-74	TRANSISTOR DTC143TS		R157	1-249-421-11	CARBON 2.2K 5% 1/4W	
Q704	8-729-900-74	TRANSISTOR DTC143TS					
Q705	8-729-141-83	TRANSISTOR 2SB1094-LK		R158	1-247-864-11	CARBON 24K 5% 1/4W	
Q706	8-729-209-15	TRANSISTOR 2SD2012		R159	1-249-434-11	CARBON 27K 5% 1/4W	
Q707	8-729-119-76	TRANSISTOR 2SA1175-HFE		R160	1-249-408-11	CARBON 180 5% 1/4W	
				R201	1-249-433-11	CARBON 22K 5% 1/4W	
Q708	8-729-140-04	TRANSISTOR 2SB1116A-L		R202	1-249-417-11	CARBON 1K 5% 1/4W	
Q801	8-729-620-05	TRANSISTOR 2SC2603-EF					
Q802	8-729-620-05	TRANSISTOR 2SC2603-EF		R203	1-249-421-11	CARBON 2.2K 5% 1/4W	
Q803	8-729-900-65	TRANSISTOR DTA144ES		R206	1-247-838-00	CARBON 2K 5% 1/4W	
Q804	8-729-900-65	TRANSISTOR DTA144ES		R208	1-247-842-11	CARBON 3K 5% 1/4W	
				R209	1-249-423-11	CARBON 3.3K 5% 1/4W	
Q805	8-729-900-80	TRANSISTOR DTC114ES		R210	1-249-428-11	CARBON 8.2K 5% 1/4W	
Q806	8-729-115-28	TRANSISTOR BN1L3Z-K					
Q807	8-729-801-93	TRANSISTOR 2SD1387		R211	1-247-864-11	CARBON 24K 5% 1/4W	
Q808	8-729-801-93	TRANSISTOR 2SD1387		R212	1-249-414-11	CARBON 560 5% 1/4W	
Q809	8-729-900-80	TRANSISTOR DTC114ES		R216	1-249-421-11	CARBON 2.2K 5% 1/4W	
				R217	1-249-429-11	CARBON 10K 5% 1/4W	
Q810	8-729-900-89	TRANSISTOR DTC144ES		R218	1-249-417-11	CARBON 1K 5% 1/4W	
Q811	8-729-900-61	TRANSISTOR DTA114ES					
Q812	8-729-119-76	TRANSISTOR 2SA1175-HFE		R226	1-249-441-11	CARBON 100K 5% 1/4W	
Q813	8-729-900-65	TRANSISTOR DTA144ES		R251	1-249-429-11	CARBON 10K 5% 1/4W	
Q814	8-729-900-65	TRANSISTOR DTA144ES		R252	1-249-428-11	CARBON 8.2K 5% 1/4W	
				R253	1-249-431-11	CARBON 15K 5% 1/4W	
Q815	8-729-900-80	TRANSISTOR DTC114ES		R254	1-249-409-11	CARBON 220 5% 1/4W	
Q816	8-729-900-80	TRANSISTOR DTC114ES					
Q817	8-729-900-80	TRANSISTOR DTC114ES		R255	1-249-429-11	CARBON 10K 5% 1/4W	
Q818	8-729-900-89	TRANSISTOR DTC144ES		R256	1-249-430-11	CARBON 12K 5% 1/4W	
Q901	8-729-900-65	TRANSISTOR DTA144ES		R257	1-249-421-11	CARBON 2.2K 5% 1/4W	
				R258	1-247-864-11	CARBON 24K 5% 1/4W	
		< RESISTOR >		R259	1-249-434-11	CARBON 27K 5% 1/4W	
R101	1-249-433-11	CARBON 22K 5% 1/4W					
R102	1-249-417-11	CARBON 1K 5% 1/4W		R260	1-249-408-11	CARBON 180 5% 1/4W	
R103	1-249-421-11	CARBON 2.2K 5% 1/4W		R501	1-249-433-11	CARBON 22K 5% 1/4W	
R106	1-247-838-00	CARBON 2K 5% 1/4W		R502	1-249-429-11	CARBON 10K 5% 1/4W	
R108	1-247-842-11	CARBON 3K 5% 1/4W		R504	1-215-455-00	METAL 27K 1% 1/6W	
				R505	1-249-417-11	CARBON 1K 5% 1/4W	
				R511	1-249-417-11	CARBON 1K 5% 1/4W	
				R512	1-249-441-11	CARBON 100K 5% 1/4W	
				R516	1-215-455-00	METAL 27K 1% 1/6W	
				R526	1-249-429-11	CARBON 10K 5% 1/4W	
				R513	1-249-425-11	CARBON 4.7K 5% 1/4W	
				R514	1-249-433-11	CARBON 22K 5% 1/4W	
				R515	1-249-433-11	CARBON 22K 5% 1/4W	

SYSTEM CONTROL

Ref. No.	Part No.	Description	Remark	Ref. No.	Part No.	Description	Remark
R701	1-249-421-11	CARBON	2.2K 5% 1/4W	R832	1-247-840-00	CARBON	2.4K 5% 1/4W
R702	1-249-425-11	CARBON	4.7K 5% 1/4W	R833	1-249-421-11	CARBON	2.2K 5% 1/4W
R704	1-249-429-11	CARBON	10K 5% 1/4W	R834	1-249-421-11	CARBON	2.2K 5% 1/4W
R705	1-249-425-11	CARBON	4.7K 5% 1/4W	R835	1-249-430-11	CARBON	12K 5% 1/4W
R706	1-249-425-11	CARBON	4.7K 5% 1/4W	R836	1-249-433-11	CARBON	22K 5% 1/4W
R707	1-249-427-11	CARBON	6.8K 5% 1/4W	R840	1-249-433-11	CARBON	22K 5% 1/4W
R708	1-249-419-11	CARBON	1.5K 5% 1/4W	R841	1-249-433-11	CARBON	22K 5% 1/4W
R709	1-249-425-11	CARBON	4.7K 5% 1/4W	R842	1-249-405-11	CARBON	100 5% 1/4W
R710	1-249-419-11	CARBON	1.5K 5% 1/4W	R843	1-249-430-11	CARBON	12K 5% 1/4W
R711	1-249-429-11	CARBON	10K 5% 1/4W	R844	1-249-433-11	CARBON	22K 5% 1/4W
R712	1-249-417-11	CARBON	1K 5% 1/4W	R848	1-249-433-11	CARBON	22K 5% 1/4W
R713	1-249-427-11	CARBON	6.8K 5% 1/4W	R849	1-249-433-11	CARBON	22K 5% 1/4W
R714	1-249-427-11	CARBON	6.8K 5% 1/4W	R850	1-249-405-11	CARBON	100 5% 1/4W
R715	1-249-430-11	CARBON	12K 5% 1/4W	R851	1-249-421-11	CARBON	2.2K 5% 1/4W
R716	1-249-429-11	CARBON	10K 5% 1/4W	R901	1-249-407-11	CARBON	150 5% 1/4W
R717	1-249-421-11	CARBON	2.2K 5% 1/4W	R902	1-249-409-11	CARBON	220 5% 1/4W
△R799	1-219-137-11	RES, FUSE	0.33 10% 1/4W	R903	1-249-411-11	CARBON	330 5% 1/4W
R801	1-249-433-11	CARBON	22K 5% 1/4W	R904	1-249-413-11	CARBON	470 5% 1/4W
R802	1-249-428-11	CARBON	8.2K 5% 1/4W	R905	1-249-415-11	CARBON	680 5% 1/4W
R803	1-247-836-11	CARBON	1.6K 5% 1/4W	R906	1-249-417-11	CARBON	1K 5% 1/4W
R804	1-249-433-11	CARBON	22K 5% 1/4W	R907	1-249-420-11	CARBON	1.8K 5% 1/4W
R805	1-249-437-11	CARBON	47K 5% 1/4W	R908	1-249-424-11	CARBON	3.9K 5% 1/4W
R806	1-247-903-00	CARBON	1M 5% 1/4W	R909	1-249-407-11	CARBON	150 5% 1/4W
R807	1-249-433-11	CARBON	22K 5% 1/4W	R910	1-249-409-11	CARBON	220 5% 1/4W
R808	1-249-433-11	CARBON	22K 5% 1/4W	R911	1-249-411-11	CARBON	330 5% 1/4W
R809	1-249-421-11	CARBON	2.2K 5% 1/4W	R912	1-249-413-11	CARBON	470 5% 1/4W
R810	1-249-421-11	CARBON	2.2K 5% 1/4W	R913	1-249-415-11	CARBON	680 5% 1/4W
R811	1-247-862-11	CARBON	20K 5% 1/4W	R914	1-249-417-11	CARBON	1K 5% 1/4W
R812	1-249-429-11	CARBON	10K 5% 1/4W	R915	1-249-420-11	CARBON	1.8K 5% 1/4W
R813	1-247-862-11	CARBON	20K 5% 1/4W	R918	1-249-417-11	CARBON	1K 5% 1/4W
R814	1-249-429-11	CARBON	10K 5% 1/4W	< VARIABLE RESISTOR >			
R815	1-249-429-11	CARBON	10K 5% 1/4W	RV101	1-238-016-11	RES, ADJ, CARBON 10K	
R816	1-249-429-11	CARBON	10K 5% 1/4W	RV201	1-238-016-11	RES, ADJ, CARBON 10K	
R817	1-249-434-11	CARBON	27K 5% 1/4W	RV901	1-241-901-11	RES, VAR, CARBON 50K/50K (BALANCE)	
R818	1-249-429-11	CARBON	10K 5% 1/4W	RV902	1-241-133-11	RES, VAR, CARBON 50K/50K (REC LEVEL)	
R819	1-249-429-11	CARBON	10K 5% 1/4W	< SWITCH >			
R820	1-249-434-11	CARBON	27K 5% 1/4W	S701	1-554-118-00	SWITCH, PUSH (1 KEY) (POWER)	
R821	1-249-421-11	CARBON	2.2K 5% 1/4W	S901	1-554-303-21	SWITCH, TACTILE (■)	
R822	1-249-429-11	CARBON	10K 5% 1/4W	S904	1-554-303-21	SWITCH, TACTILE (◀)	
R823	1-249-421-11	CARBON	2.2K 5% 1/4W	S905	1-554-303-21	SWITCH, TACTILE (▶)	
R824	1-249-429-11	CARBON	10K 5% 1/4W	S906	1-554-303-21	SWITCH, TACTILE (●)	
R825	1-249-422-11	CARBON	2.7K 5% 1/4W	S907	1-554-303-21	SWITCH, TACTILE (HIGH SPEED)	
R826	1-249-422-11	CARBON	2.7K 5% 1/4W	S908	1-554-303-21	SWITCH, TACTILE (NORMAL SPEED)	
R827	1-249-422-11	CARBON	2.7K 5% 1/4W	S909	1-554-303-21	SWITCH, TACTILE (COUNTER RESET)	
R828	1-249-429-11	CARBON	10K 5% 1/4W	S911	1-554-303-21	SWITCH, TACTILE (■)	
R830	1-249-429-11	CARBON	10K 5% 1/4W	S912	1-554-303-21	SWITCH, TACTILE (■)	
R831	1-249-424-11	CARBON	3.9K 5% 1/4W				

Note:
The components identified by mark Δ or dotted line with mark Δ are critical for safety. Replace only with part number specified.

Note:
Les composants identifiés par une marque Δ sont critiques pour la sécurité. Ne les remplacer que par une pièce portant le numéro spécifié.

SYSTEM CONTROL

Ref. No.	Part No.	Description	Remark
S915	1-554-303-21	SWITCH, TACTILE (⊕)	
S916	1-554-303-21	SWITCH, TACTILE (⊔)	
S917	1-554-303-21	SWITCH, TACTILE (⊓)	
S918	1-554-303-21	SWITCH, TACTILE (COUNTER RESET)	
S919	1-554-303-21	SWITCH, TACTILE (▶)	
S920	1-554-303-21	SWITCH, TACTILE (▶)	
S921	1-692-126-11	SWITCH, SLIDE (DOLBY)	
< FLUORESCENT INDICATOR >			
VFD901	1-519-712-11	INDICATOR TUBE, FLUORESCENT	
< VIBRATOR >			
X801	1-577-358-21	VIBRATOR, CERAMIC (4MHZ)	

MISCELLANEOUS *****			
△2	1-569-007-11	ADAPTER, CONVERSION 2P (E)	
△4	1-551-188-XX	CORD, POWER (E)	
△4	1-555-795-00	CORD, POWER, EULO PLUG (AEP)	
△4	1-556-035-00	CORD, POWER (UK)	
△4	1-558-945-11	CORD, POWER (POLAR. SPT-1) (US, Canadian)	
10	1-690-891-11	WIRE, FLAT TYPE (11 CORE)	
11	1-690-889-11	WIRE, FLAT TYPE (9 CORE)	
12	1-690-890-11	WIRE, FLAT TYPE (9 CORE)	
68	1-690-888-11	WIRE, FLAT TYPE (31 CORE)	
69	1-690-901-11	WIRE (FLAT TYPE) (5 CORE)	
△F701	1-532-285-00	FUSE (AEP, UK, E)	
△F701	1-576-103-11	FUSE (US, Canadian)	
△F702	1-532-285-00	FUSE (AEP, UK, E)	
△F702	1-576-103-11	FUSE (US, Canadian)	
HE101	1-543-673-11	HEAD, MAGNETIC (ERASE) (DECK B)	
HP101	1-543-920-11	HEAD, MAGNETIC (PLAYBACK)	
HRP101	1-543-919-11	HEAD, MAGNETIC (RECORD/PLAYBACK)	
M1	X-3359-417-1	MOTOR ASSY, CAPSTAN	
M2	X-3363-501-1	MOTOR ASSY, REEL	
△T901	1-450-837-11	TRANSFORMER, POWER (US, Canadian)	
△T901	1-450-838-11	TRANSFORMER, POWER (AEP, UK)	
△T901	1-450-839-11	TRANSFORMER, POWER (E)	
△VS901	1-691-155-11	VOLTAGE SELECTOR (E)	

Ref. No.	Part No.	Description	Remark
ACCESSORIES & PACKING MATERIALS *****			
	1-558-271-11	CORD, CONNECTION	
*	3-366-701-61	INDIVIDUAL CARTON	
*	3-704-343-01	SHEET (STANDARD), PROTECTION	
	3-754-778-11	MANUAL, INSTRUCTION (AEP, E) (English, French, Spanish, Portuguese)	
	3-754-778-21	MANUAL, INSTRUCTION (US, Canadian, UK) (English)	
	3-754-778-31	MANUAL, INSTRUCTION (Canadian) (French)	
	3-754-778-41	MANUAL, INSTRUCTION (AEP) (Germany, Dutch, Italian, Swedish)	
	3-754-778-61	MANUAL, INSTRUCTION (E) (Chinese)	
	3-754-778-71	MANUAL, INSTRUCTION (AEP) (Danish, Finnish)	
	9-910-999-33	INSTRUCTION (US)	

***** HARDWARE LIST *****			
#1	7-621-773-93	SCREW (PANEL 2.6 TP2)	
#2	7-621-773-95	SCREW +BVTT 2.6X6 (S)	
#3	7-621-849-00	SCREW (BV/RING)	
#4	7-682-547-04	SCREW +BVTT 3X6 (S)	
#5	7-682-548-09	SCREW +BVTT 3X8 (S)	
#6	7-685-646-79	SCREW +BVTP 3X8 TYPE2 IT-3	
#7	7-682-547-09	SCREW +BVTT 3X6 (S)	
#8	7-621-772-58	SCREW (+B2X10)	

<p>Note: The components identified by mark △ or dotted line with mark △ are critical for safety. Replace only with part number specified.</p>	<p>Note: Les composants identifiés par une marque △ sont critiques pour la sécurité. Ne les remplacer que par une pièce portant le numéro spécifié.</p>
---	---

TC-W490

SONY[®] SERVICE MANUAL

*US Model
Canadian Model
AEP Model
UK Model
E Model*

CORRECTION-1

File this Correction with the Service Manual.

- | |
|---|
| 1. SECTION 4 ADJUSTMENTS (Page 9) |
| 2. SECTION 5 SCHEMATIC DIAGRAM (AUDIO SECTION) (Page 28 – 32) |
| 3. SECTION 6 CHASSIS SECTION (Page 33) |

• SECTION 4 ADJUSTMENTS (Page 9)

(Correct)

Torque Measurement

Torque	Torque	Meter reading
Forward	CQ-102C	30 to 65g•cm (0.42 to 0.9oz•inch)
Forward back tension	CQ-102C	DECK A : 1 to 6g•cm (0.014 to 0.08 oz•inch) DECK B : 2 to 9g•cm (0.03 to 0.12 oz•inch)
FF/REW	CQ-201B	70 to 120g•cm (0.98 to 1.67 oz•inch)

• SECTION 6 CHASSIS SECTION (Page 33)

(Added)

Ref. No.	Part No.	Description	Remark
-----	-----	-----	-----
5	4-943-148-42	FOOT (AEP, UK, E)	

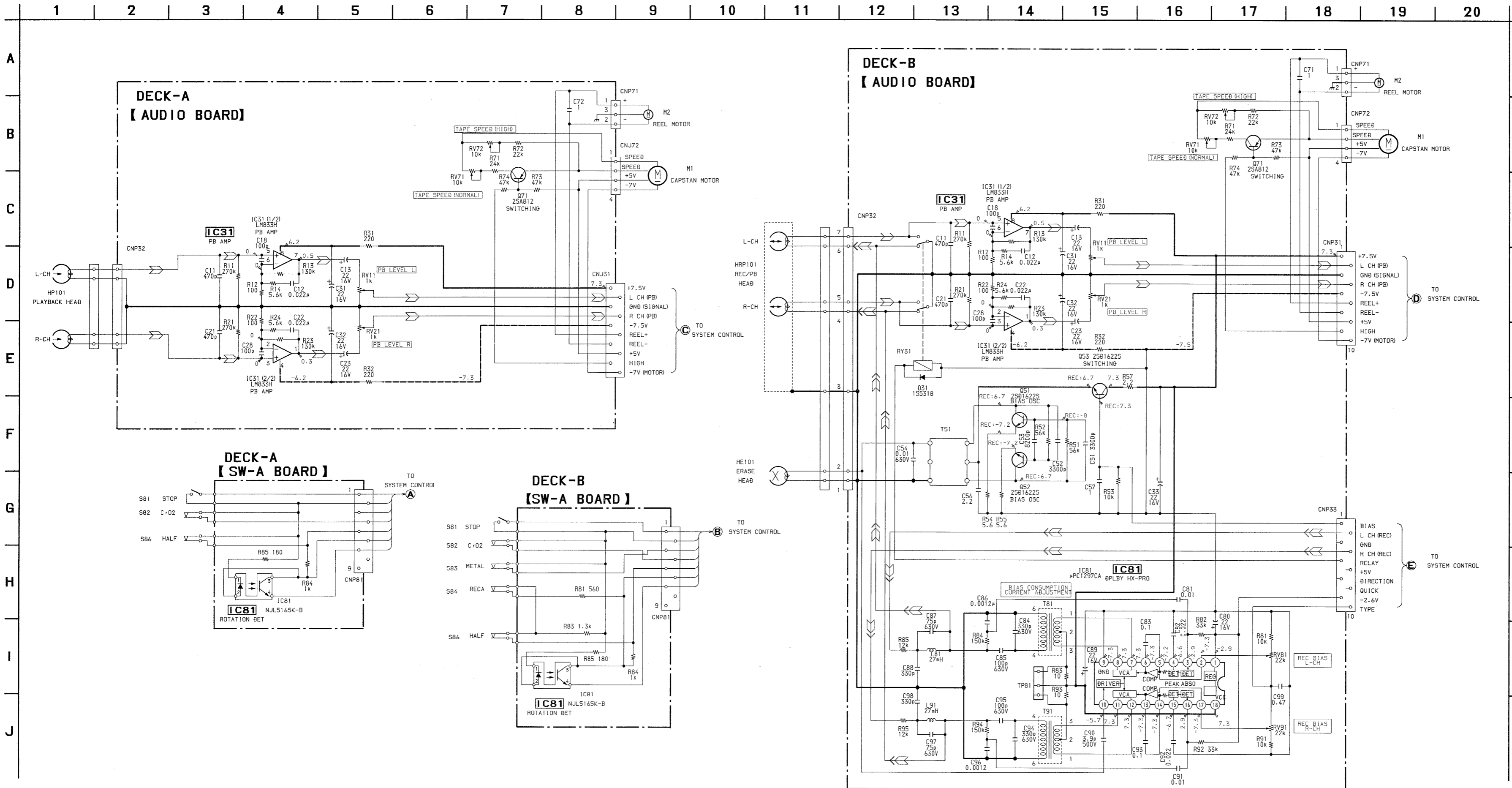

Note:

- All capacitors are in μF unless otherwise noted. pF: $\mu\mu F$. 50WV or less are not indicated except for electrolytics and tantalums.
- All resistors are in Ω and $\frac{1}{4}W$ or less unless otherwise specified.
- % : indicates tolerance.
- Δ : internal component.
- : B+ Line
- : B- Line
- : adjustment for repair.
- Voltage and waveforms are dc with respect to ground under no-signal.
- no mark : STOP
- ▷ : FWD
- ◁ : REV
- ⊙ : REC
- Voltages are taken with a VOM (Input impedance 10M Ω). Voltage variations may be noted due to normal production tolerances.
- Signal path.
 - ▷ : PB (DECK A)
 - ◁ : REC (DECK B)