

TC-K561S/KA1ES

SERVICE MANUAL



Photo : TC-K561S

US Model
TC-KA1ES
AEP Model
UK Model
Australian Model
E Model
TC-K561S

* Dolby noise reduction and HX Pro headroom extension manufactured under license from Dolby Laboratories Licensing Corporation. HX Pro originated by Bang & Olufsen.

"DOLBY", the double-D symbol $\square\square$ and "HX PRO" are trademarks of Dolby Laboratories Licensing Corporation.

Model Name Using Similar Mechanism	TCK411/K511S
Tape Transport Mechanism Type	TCM-190VB14

SPECIFICATIONS

Recording system 4-track 2-channel stereo
Fast winding time Approx. 90 sec. (with Sony C-60 cassette)
Bias AC bias
Heads Erasing head \times 1 (S&F head)
Recording head \times 1 (SD head)
Playback head \times 1 (SD head)
Motors Capstan motor \times 1 (DC servo motor)
Reel motor \times 1 (DC motor)

Signal-to-noise ratio (at peak level and weighted)

Cassette (Dolby NR off)	Type IV	Type II	Type I
	61 dB	59 dB	57 dB

S/N ratio improvement (approximate values).

With Dolby B NR on: 5 dB at 1 kHz; 10 dB at 5 kHz
With Dolby C NR on: 15 dB at 500 Hz; 20 dB at 1 kHz
With Dolby S NR on: 10 dB at 100 Hz; 24 dB at 1 kHz

Harmonic distortion 0.4% (with Type I, 160 nWb/m
315 Hz, 3rd H.D.)
1.5% (with Type IV, 250 nWb/m
315 Hz, 3rd H.D.)

Frequency response (Dolby NR off)

Type IV cassette	30 - 19,000 Hz (\pm 3 dB, IEC) 30 - 16,000 Hz [\pm 3 dB (-4 dB recording)]
Type II cassette	30 - 18,000 Hz (\pm 3 dB, IEC)
Type I cassette	30 - 17,000 Hz (\pm 3 dB, IEC)

Type IV : Sony Type IV (METAL)
Type II : Sony Type II (HIGH)
Type I : Sony Type I (NORMAL)

Wow and flutter \pm 0.085% W.Peak (IEC)
0.055% W.RMS (NAB)
 \pm 0.16% W.Peak (DIN)

Inputs

Line inputs (phono jacks)	Sensitivity	0.16 V
	Input impedance	47 k ohms

Outputs

Line outputs (phono jacks)	Rated output level	0.5 V at a load impedance of 47 k ohms
	Load impedance	Over 10 k ohms
Headphones (stereo phone jack)	Output level	1 mW at a load impedance of 32 ohms

General

Power requirements

US model :
120 V AC, 60 Hz
AEP, German model :
220 - 230 V AC, 50/60 Hz
UK, Australian model :
240 V AC, 50/60 Hz
E model :
120, 220 or 240 V AC
adjustable, 50/60 Hz

Power consumption

23 W

Dimensions

Approx. 430 \times 123 \times 310 mm (w/h/d)
including projecting parts and controls
Approx. 4.2 kg

Mass

Supplied accessories

Audio connecting cords (2)

Design and specifications are subject to change without notice.

STEREO CASSETTE DECK
SONY[®]

TABLE OF CONTENTS

<i>Section</i>	<i>Title</i>	<i>Page</i>	<i>Section</i>	<i>Title</i>	<i>Page</i>
Specifications		1	5. DIAGRAMS		
1. GENERAL			5-1. Block Diagram		13
Identifying the Parts on the Front Panel		4	5-2. Circuit Boards Location		16
2. DISASSEMBLY			5-3. Printed Wiring Boards (Main Section)		17
2-1. Front Panel		5	5-4. Schematic Diagram (Main Section)		21
2-2. Mechanism Deck		5	5-5. Printed Wiring Boards (Dolby (S) Board)		25
2-3. Head		6	5-6. Schematic Diagram (Dolby (S) Board)		25
2-4. Fitting Base Block		6	6. EXPLODED VIEWS		
2-5. Motor		6	6-1. Chassis Section		27
3. ADJUSTMENTS			6-2. Front Panel Section		28
3-1. Mechanical Adjustments		7	6-3. Mechanism Section 1		29
3-2. Electrical Adjustments		7	6-4. Mechanism Section 2		30
4. EXPLANATION OF IC TERMINALS		11	7. ELECTRICAL PARTS LIST		31

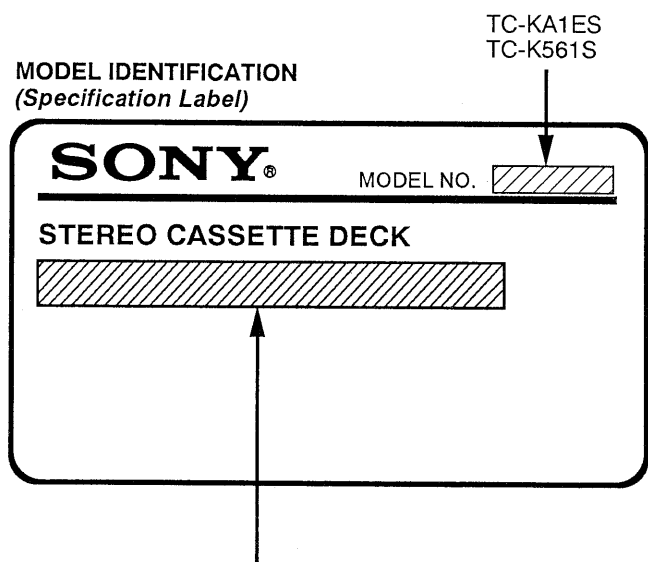

US model : AC 120V~60Hz
 AEP, German model : AC 220-230V~50/60Hz
 UK, Australian model : AC 240V~50/60Hz
 E model : AC 120, 220 or 240V
 adjustable~50/60Hz

SAFETY-RELATED COMPONENT WARNING!!

COMPONENTS IDENTIFIED BY MARK OR DOTTED LINE WITH MARK ON THE SCHEMATIC DIAGRAMS AND IN THE PARTS LIST ARE CRITICAL TO SAFE OPERATION. REPLACE THESE COMPONENTS WITH SONY PARTS WHOSE PART NUMBERS APPEAR AS SHOWN IN THIS MANUAL OR IN SUPPLEMENTS PUBLISHED BY SONY.

SAFETY CHECK-OUT

After correcting the original service problem, perform the following safety check before releasing the set to the customer:

Check the antenna terminals, metal trim, "metallized" knobs, screws, and all other exposed metal parts for AC leakage. Check leakage as described below.

LEAKAGE TEST

The AC leakage from any exposed metal part to earth ground and from all exposed metal parts to any exposed metal part having a return to chassis, must not exceed 0.5 mA (500 microampers). Leakage current can be measured by any one of three methods.

1. A commercial leakage tester, such as the Simpson 229 or RCA WT-540A. Follow the manufacturers' instructions to use these instruments.
2. A battery-operated AC milliammeter. The Data Precision 245 digital multimeter is suitable for this job.

3. Measuring the voltage drop across a resistor by means of a VOM or battery-operated AC voltmeter. The "limit" indication is 0.75 V, so analog meters must have an accurate low-voltage scale. The Simpson 250 and Sanwa SH-63Trd are examples of a passive VOM that is suitable. Nearly all battery operated digital multimeters that have a 2V AC range are suitable. (See Fig. A)

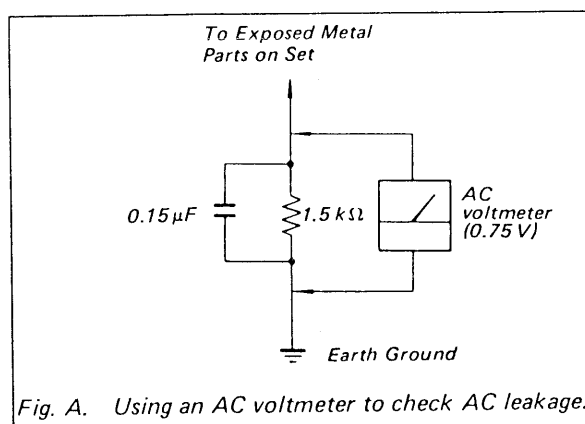
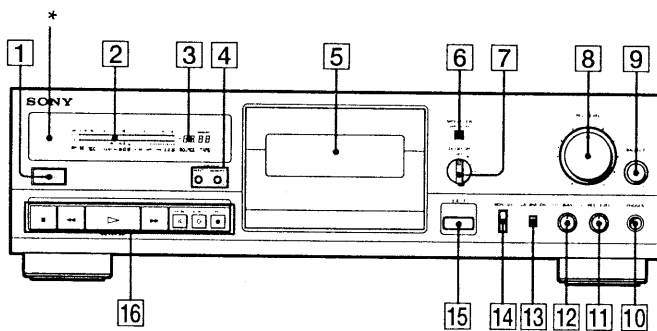

Fig. A. Using an AC voltmeter to check AC leakage.



SECTION 1 GENERAL

This section is extracted from instruction manual.

Identifying the Parts on the Front Panel



- 1 POWER switch
- 2 Peak level meters
- 3 Linear counter
- 4 COUNTER buttons
RESET button
MEMORY button
- 5 Cassette holder
- 6 MPX FILTER button
- 7 DOLBY NR (noise reduction) switch
- 8 REC (recording) LEVEL control
- 9 BALANCE control
- 10 PHONES jack (stereo phone jack)
- 11 REC (recording) LEVEL control for calibration
- 12 BIAS control
- 13 CALIBRATION button
- 14 MONITOR button
- 15 ≡ (EJECT) button
- 16 Tape operation buttons
 - (stop) button
 - ◀◀ (rewind) (Multi-AMS**) button
 - ▷ (play) button
 - ▶▶ (fast-forward) (Multi-AMS**) button
 - || PAUSE button
 - REC MUTE (record muting) button (42)
 - REC (recording) button

- *Remote control sensor
You can remotely control this cassette deck with:
- A remote commander that came with a Sony amplifier or receiver if it has the  mark and cassette deck control capability.
 - An optional Sony remote commander with the  mark and cassette deck control capability.

** AMS is an abbreviation for Automatic Music Sensor.

SECTION 2 DISASSEMBLY

Note : Follow the disassembly procedure in the numerical order given.

CASE

Unscrew the four case attachment screws M3 × 8 and remove the case.

2-1. FRONT PANEL

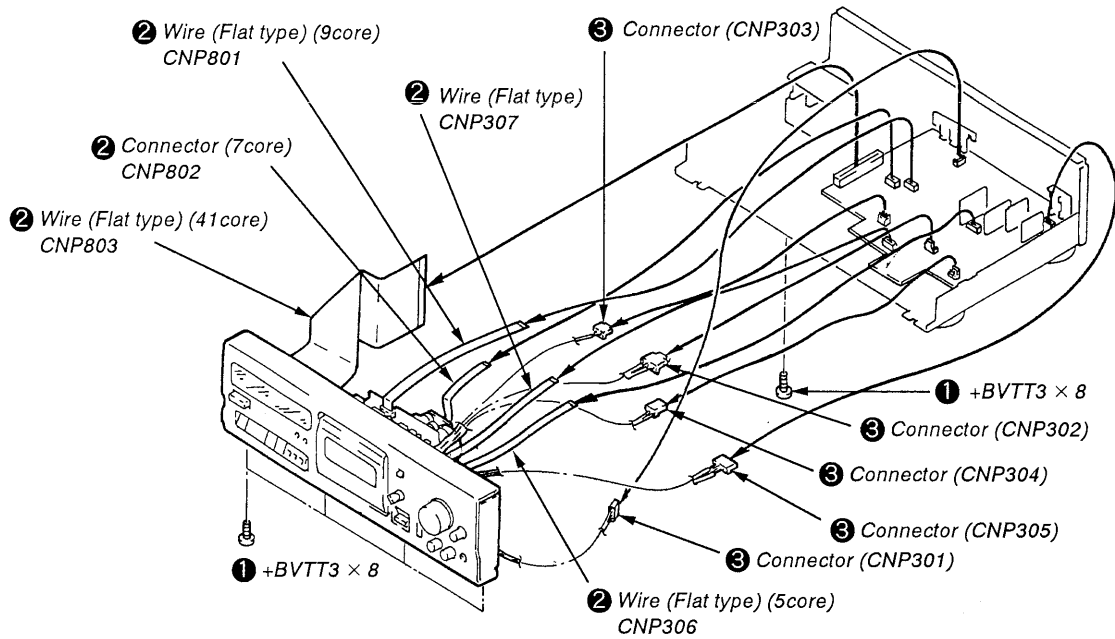

2-2. MECHANISM DECK

① Press the eject button.

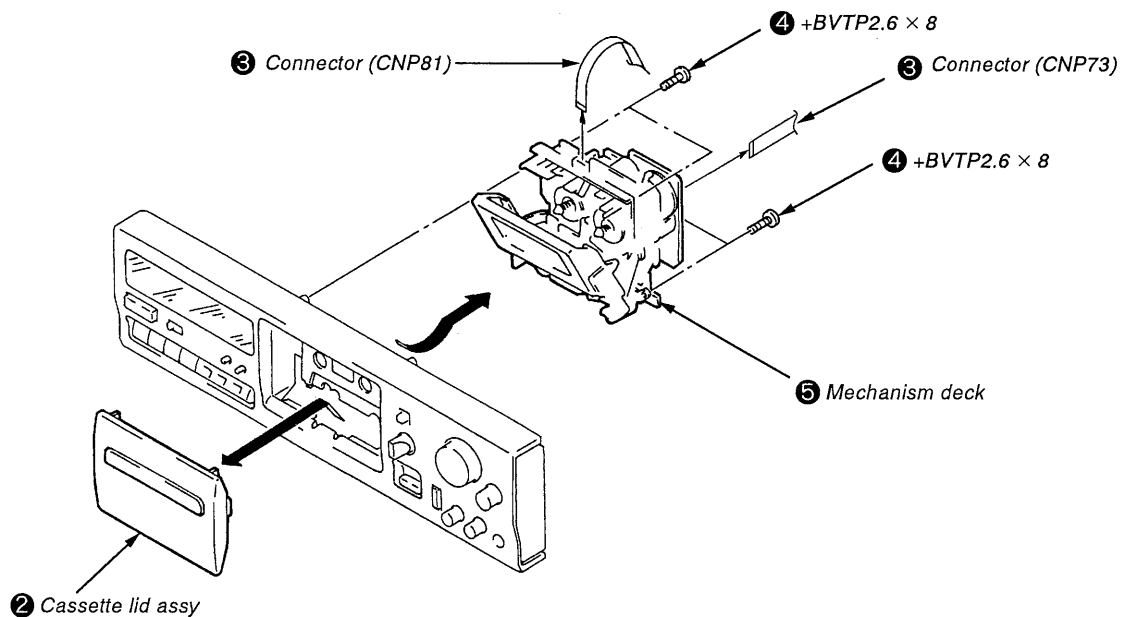

2-3. HEAD

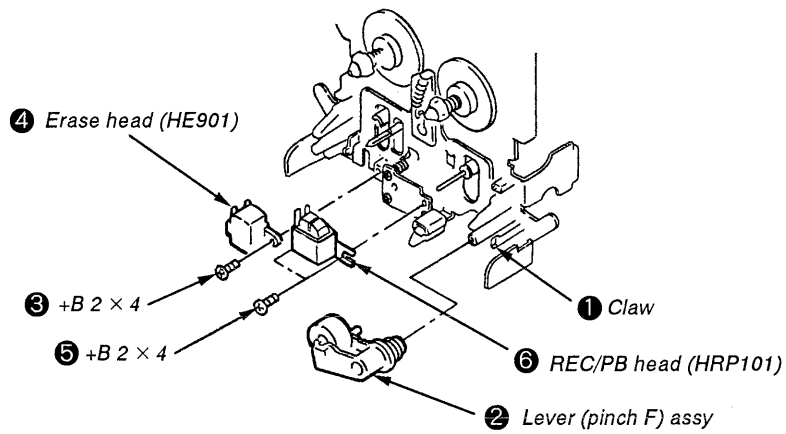

2-4. FITTING BASE BLOCK

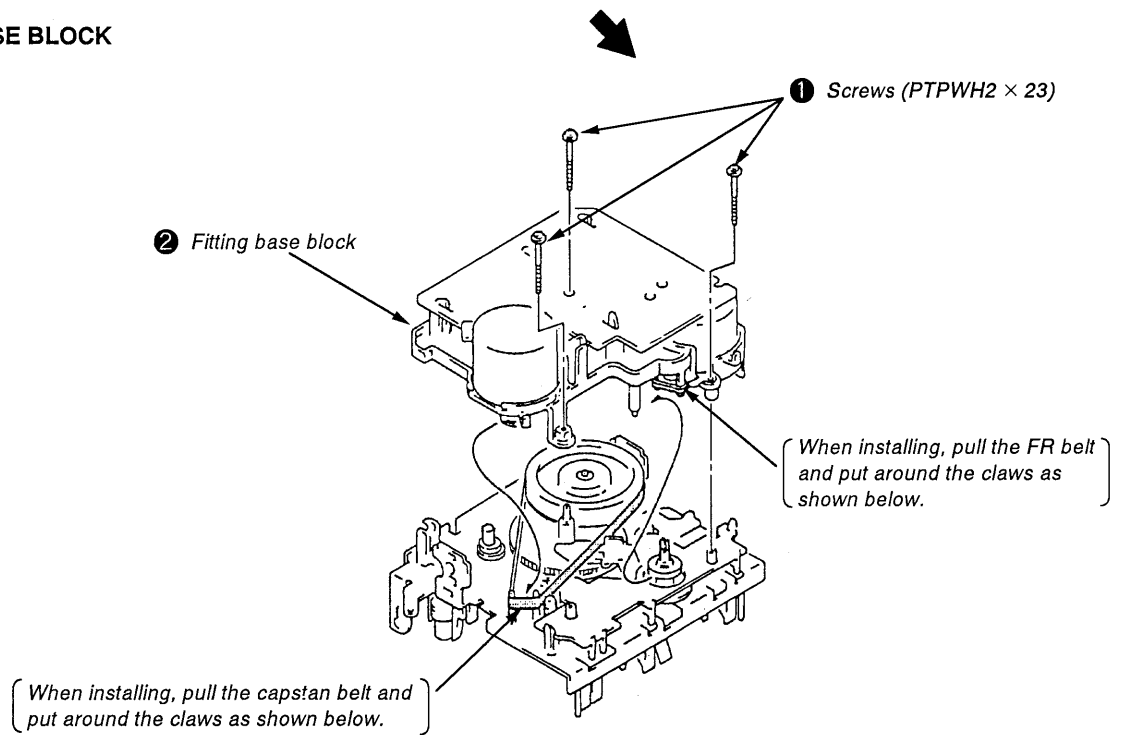

2-5. MOTOR

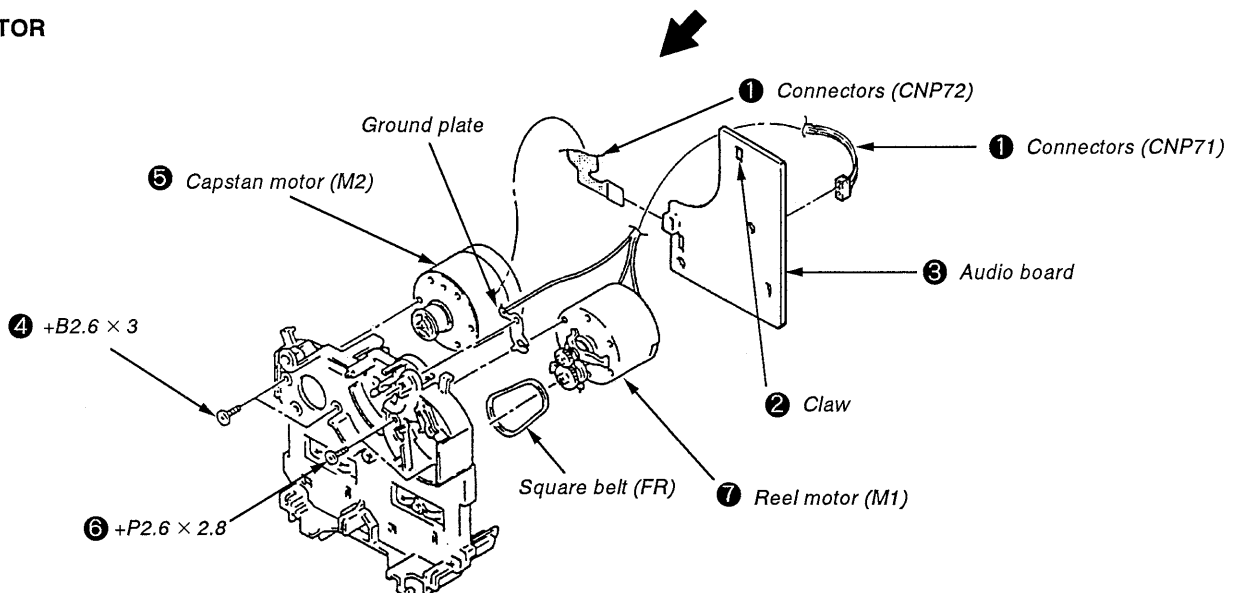

SECTION 3 ADJUSTMENTS

3-1. MECHANICAL ADJUSTMENTS

PRECAUTION

1. Clean the following parts with a denatured alcohol-moistened swab:

record/playback/erase head	pinch roller
rubber belts	capstan
idlers	
2. Demagnetize the record/playback head with a head demagnetizer. (Head demagnetizer do not approach for the erase head.)
3. Do not use a magnetized screwdriver for the adjustment.
4. After the adjustments, apply suitable locking compound to the parts adjusted.
5. The adjustments should be performed with the rated power supply voltage unless otherwise noted.

Torque Measurement

Mode	Torque meter	Meter reading
Forward	CQ-102C	30 to 65g•cm (0.42 to 0.90oz•inch)
Forward back tension	CQ-102C	1 to 6g•cm (0.014 to 0.08 oz•inch)
FF/REW	CQ-201B	70 to 120g•cm (0.98 to 1.66 oz•inch)

Record/Playback Head Height/Declination Adjustment

Procedures :

1. Test cassette : CQ-009C
2. Insert the mirror cassette and put the unit in record/Playback mode.

1) Height Adjustment :

Check to see if the tape is curling at the tape guide of the head. If it is curling, tighten screws **A**, **B** and **C**, respectively by the same angle, moving the head so that it remains at the same angle throughout the procedure. If it curls on the bottom side of the mirror cassette (actually the inner side), tighten all the screws equally ; but loosen them if the tape begins to curl on the top side (outer side).

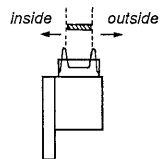

Normal
(Record/playback head
as seen from the side
of the erasehead.)

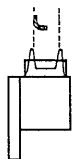

Curling on the inner
side
Tighten screws **A**, **B**
and **C**.

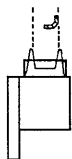

Curling on the outer
side
Loosen screws **A**, **B**
and **C**.

2) Declination Adjustment :

While in the record/playback position, set the back tension to 0 (wind the supply reel with something thin like a pencil in a counterclockwise direction) and make sure there is no curling or shifting (shifting up/shifting down) at the guide of the record/playback head.

Because shifting can only occur due to a difference in the width of the tape and that of the tape guides (curling will otherwise occur), it is necessary to pay close attention since it can be easily overlooked.

When there is a shift, tighten screws **B** and **C** equally and change the declination of the head. If the tape is shifting up, tighten the screws, and if it is shifting down, loosen them.

Repeat the adjustments in steps 1) to 2) and fine adjust the height and the declination.

Adjustment Location : — record/playback head —

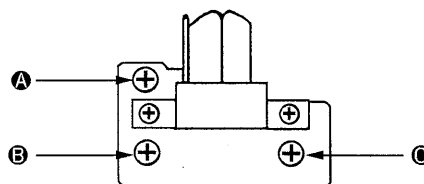

3-2. ELECTRICAL ADJUSTMENTS

PRECAUTION

1. The adjustment should be performed in the publication. (Be sure to make playback adjustment at first.)
2. The adjustments and measurement should be performed for both L-CH and R-CH.
 - Switch position
DOLBY NR switch : OFF
 - Standard record position:
Deliver the standard input signal level to input jack and set the REC LEVEL control to obtain the standard output signal level as follows.

— Record Mode —

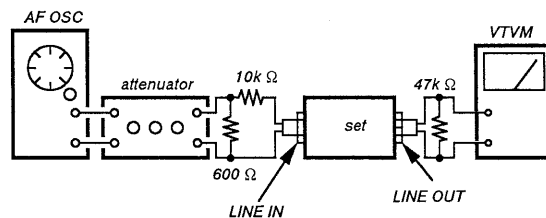

Standard Input Level

Input terminal	LINE IN
source impedance	10k Ω
input signal level	0.5V (- 3.8dB)

Standard Output Level

Output terminal	LINE OUT
load impedance	47k Ω
output signal level	0.5V (- 3.8dB)

Test Tape

Tape	Contents	Use
P-4-A100	10kHz, - 10dB	Azimuth Adjustment
P-4-L300	315Hz, 0dB	PB Level Adjustment
WS-48B	3kHz, 0dB	Tape Speed Adjustment

0dB=0.775V

3. Phase check

Playback Mode

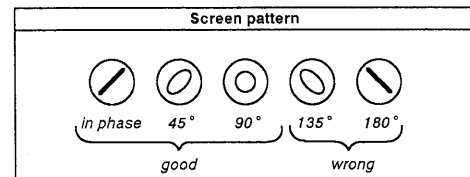
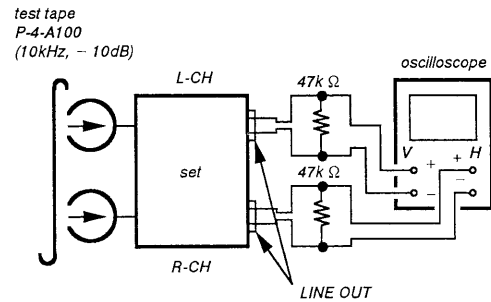

- After the adjustment, lock the adjustment screws with suitable locking compound.

Adjustment Location : - record/playback head -

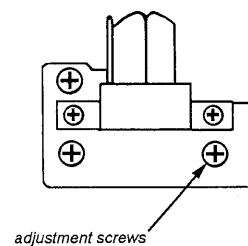

Tape Speed Adjustment

Procedure :

- Forward Playback Mode -

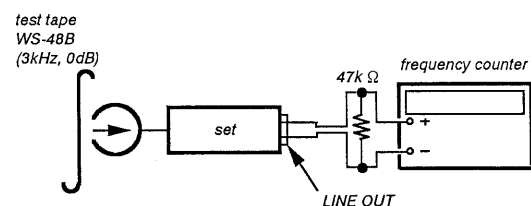

- Set to FWD playback mode.
- Adjust RV71 so that the frequency counter reading becomes $3,000 \pm 15\text{Hz}$.

Frequency difference between the beginning and the end of the tape should be within 3%.

Adjustment Location : AUDIO board (Page 10)

Test Mode

- Insert a short-circuit plug into TP801 (2P) and turn ON the power switch. (Earth pin $\text{\textcircled{R}}$ of IC801 and turn ON the power switch.)

At first, all the fluorescent tubes light up, then the system returns to normal display. (However, "0000" is not displayed on the counter.)

- To release the test mode, remove the short plug and turn off the power switch.
- Remove the short plug after completion of adjustment.

Record/Playback Head Azimuth Adjustment

Procedure :

- Forward playback Mode

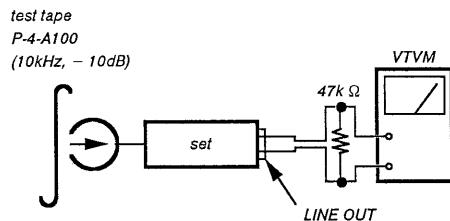

- Turn the adjustment screw for the maximum output levels. If these levels do not match, turn the adjustment screw until both of output levels match together within 1dB.

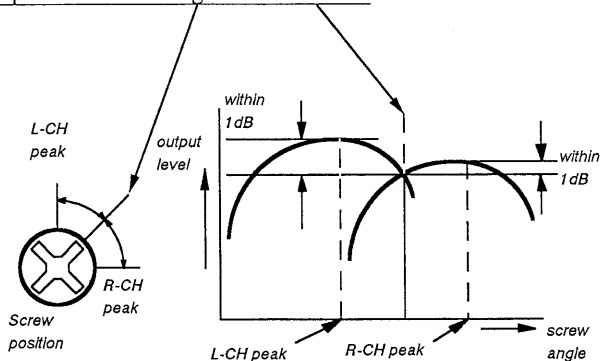

Playback Level Adjustment

Procedure :

– Forward Playback Mode –

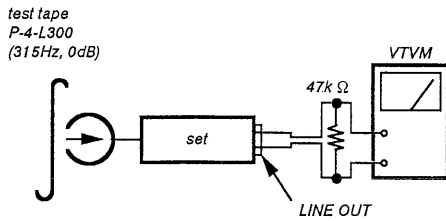

Adjust RV121 (L-CH) and RV221 (R-CH) so the VTVM reading becomes the adjustment limits below.

Adjustment Value :

LINE OUT level : $-7.7 \pm 0.5\text{dB}$ (0.301 to 0.338V)

Level difference between channels : within 0.5dB

Confirm the LINE OUT level does not change in playback mode while changing the mode from playback to stop several times

Adjustment Location : MAIN board (Page 10)

Bias Consumption Current Adjustment

This adjustment should be performed when replacing the head assy or the bias oscillating transformer (T101, T201).

Procedure :

() : R-CH

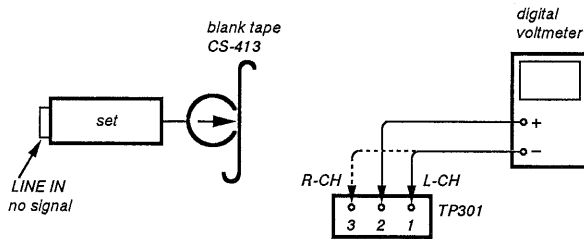

1. Connect the digital voltmeter to test point TP301.
2. Set RV103 (RV203) to mechanical center.
3. Set to FWD record mode.
4. Adjust T101 (T201) so that the digital voltmeter reading becomes minimum.

Adjustment Location : MAIN board (Page 10)

Record Level Adjustment

Setting :

REC LEVEL control : standard record position (Refer to page 7.)

Procedure :

1. Record Mode

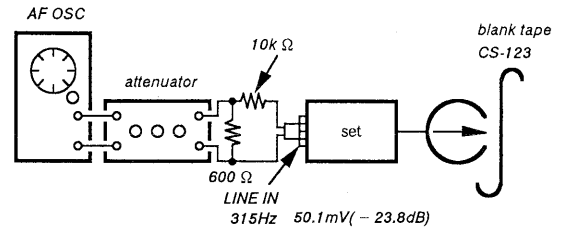

2. Playback Mode

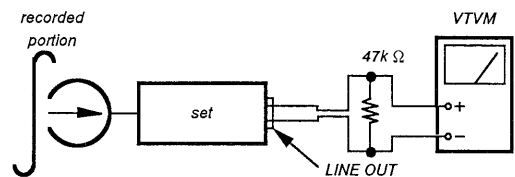

Confirm playback the tape recorded become adjustment level as follows.

If necessary, adjust RV101 (L-CH), RV201 (R-CH) and repeat the steps 1 and 2.

Adjustment Value :

LINE OUT level : $-23.8 \pm 0.5\text{dB}$ (47.2 to 53mV)

Adjustment Location : MAIN board (Page 10)

– Adjustment Parts Location Diagrams –

Record Bias Adjustment

Setting :

REC LEVEL control : standard record position (Refer to page 7.)

Procedure :

1. Record Mode

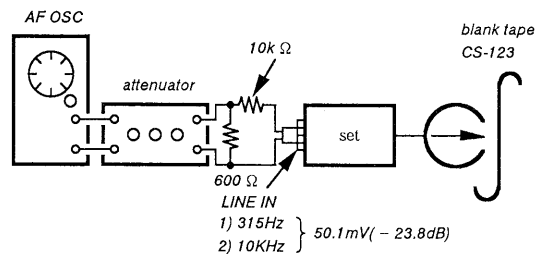

2. Playback Mode

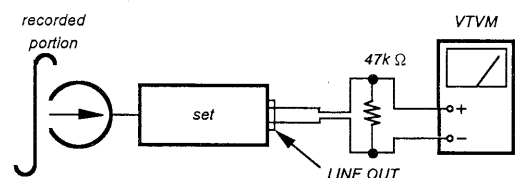

Confirm that the 10kHz playback output is $0 \pm 0.3\text{dB}$ relative to the 315Hz output. If necessary, adjust RV103 (L-CH), RV203 (R-CH) and repeat the steps given above.

Adjustment Location : MAIN board

Record EQ (IV) Adjustment

Setting :

REC LEVEL control : standard record position (Refer to page 7.)

Procedure :

1. Record Mode

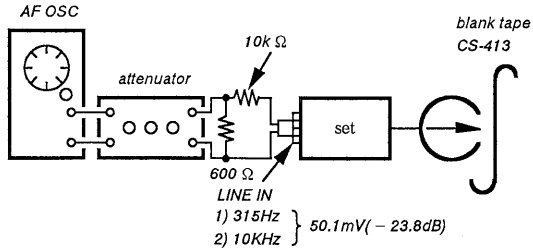

2. Playback Mode

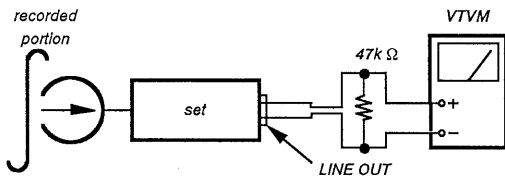

1. Adjust RV102 and 202 so that they become maximum.
2. Adjust RV102 (L-CH) and 202(R-CH) so that the difference between R-CH and L-CH at 10 kHz is within 1dB.
3. Adjust RV306 so that the value of R-CH becomes the specified value.

Specified value :
(the level at 10kHz against to 315Hz : $0\text{dB} \pm 1\text{dB}$)

Adjustment Location : MAIN board

— Adjustment Parts Location Diagrams —

[MAIN BOARD]

(Component Side)

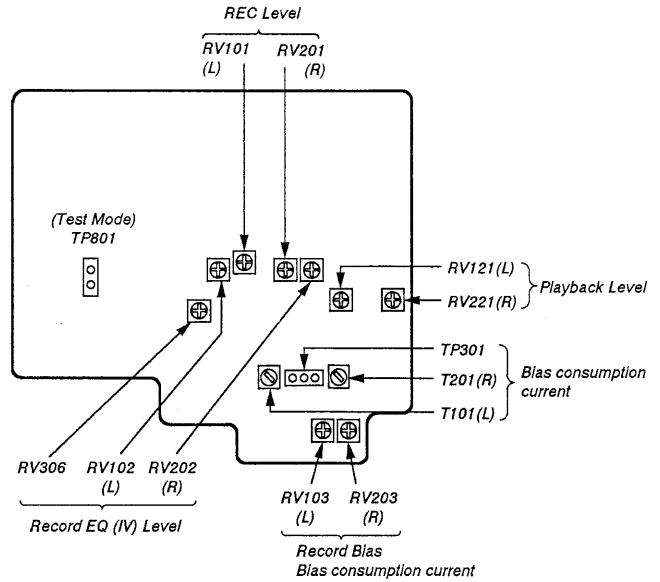

[AUDIO BOARD]

(Component Side)

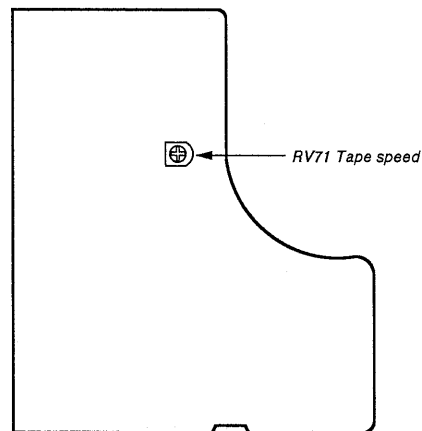

SECTION 4 EXPLANATION OF IC TERMINALS

IC801 μ PD78042GF-072-3B9

Pin No.	Pin name	I/O	Description
1	IV	O	BIAS EQ IV control.
2	P25	O	VFD Segment drive.
3	G5-MODE	O	VFD colum mode.
4	G4-SEC	O	VFD colum Sec.
5	G3-MIN	O	VFD colum Min.
6	G2-RCH	O	VFD colum R-CH.
7	G1-LCH	O	VFD colum L-CH.
8	V _{DD}	—	Power supply. (+5V)
9	NC	—	Not used. (OPEN)
10	NC	—	Not used. (OPEN)
11	REEL -	O	Reel motor - output terminal.
12	REEL+	O	Reel motor + output terminal.
13	NC	—	Not used. (OPEN)
14	NC	—	Not used. (OPEN)
15	TYPE • II	I	Type II SW input terminal.
16	TYPE • IV	I	Type IV SW input terminal.
17	RESET	I	System reset terminal.
18	NC	—	Not used. (High level)
19	TEST	I	Test mode terminal. "H" : Normal, "L" : Test mode
20	AV _{SS}	—	Analog for power supply. (GND)
21	KEY2	I	Key input terminal.
22	KEY1	I	Key input terminal.
23	T • PULSE	I	Take up pulse input terminal.
24	S • PULSE	I	Supply pulse input terminal.
25	HALF-SW	I	Half pawl input terminal.
26	DOLBY SW	I	Dolby SW input terminal.
27	METER-L	I	Meter level L-CH input terminal.
28	METER-R	I	Meter level R-CH input terminal.
29	AV _{DD}	—	Analog for power supply. (+5V)
30	AV _{ref}	—	A/D referance voltage. (+5V)
31	AMS-SIG	I	AMS signal input terminal.
32	XT2	—	Not used. (OPEN)
33	V _{SS}	—	Power supply. (GND)
34	XI	I	System clock input terminal.
35	XO	O	System clock output terminal.
36	C • M	O	Capstan motor ON/OFF control. ON=0V
37	NC	—	Not used. (High level)
38	NC	—	Not used. (High level)
39	STOP-SW	I	Mechanism stop switch input terminal.
40	NC	—	Not used. (High level)

Pin No.	Pin name	I/O	Description
41	NC	–	Not used. (GND)
42	NC	–	Not used. (GND)
43	NC	–	Not used. (OPEN)
44	FLY WHEEL PULSE	–	Not used. (GND)
45	POWER OUT	O	Power ON/OFF control.
46	POWER IN	I	Power OFF. OFF=0V
47	SIRCS	I	SIRCS signal input terminal.
48	IC	–	Not used. (GND)
49	CAL 1 ON/OFF	O	Calibration ON/OFF control terminal.
50	CAL 2 H/L	O	Calibration H/L control terminal.
51	BIAS	O	BIAS ON/OFF control.
52	VDD	–	Power supply. (+5V)
53	MONITER	O	Audio mode select terminal.
54	REC-MUT	O	REC out mute control.
55	LINE-MUT	O	Line mute ON/OFF control terminal.
56	DOLBY CON.	O	Dolby ON/OFF control terminal.
57	SEG B	O	VFD segment drive. (Dolby B)
58	SEG C	O	VFD segment drive. (Dolby C)
59	SEG FIL	O	VFD segment drive. (Filter)
60	SEG S	O	VFD segment drive. (Dolby S)
61	P1	O	VFD segment drive.
62	P2	O	
63	P6	O	
64	P7	O	
65	P3	O	
66	P5	O	
67	P4	O	
68	P8	O	
69	P16	O	
70	P9	O	
71	– 21V	–	VFD power supply. (– 21V)
72	P10	O	VFD segment drive.
73	P14	O	
74	P15	O	
75	P11	O	
76	P13	O	
77	P12	O	
78	RECCAL	O	VFD segment drive. (REC CAL)
79	I	O	BIAS EQ I control.
80	II	O	BIAS EQ II control.

SECTION 5
DIAGRAMS

5-1. BLOCK DIAGRAM

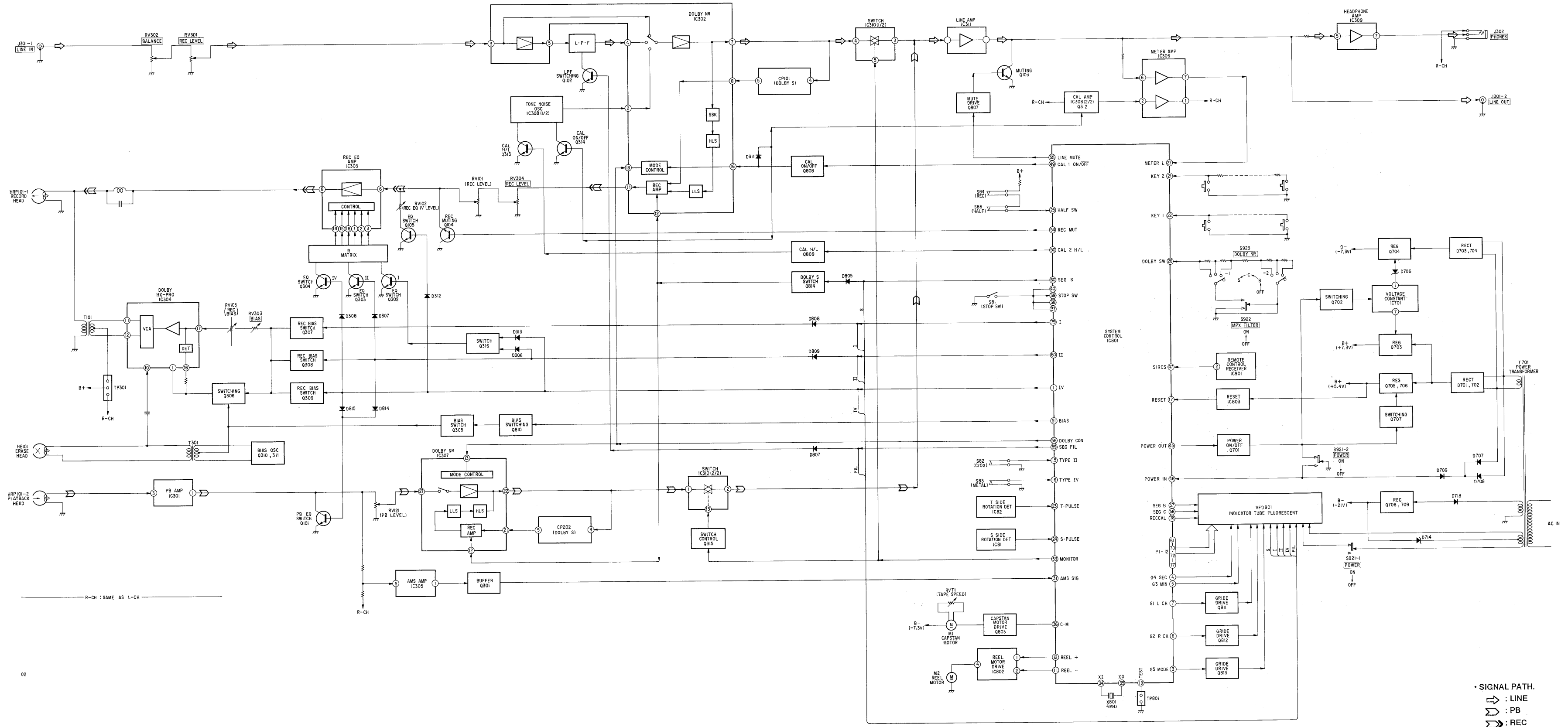

5-2. CIRCUIT BOARDS LOCATION

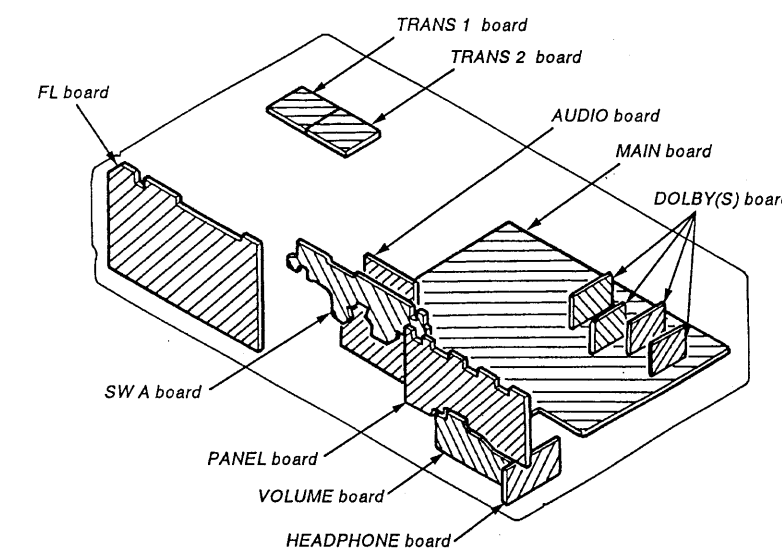

● SEMICONDUCTOR LOCATION

Ref. No.	Location	Ref. No.	Location	Ref. No.	Location	Ref. No.	Location
D101	B-17	D715	C-21	IC801	G-19	Q316	G-16
D102	B-17	D718	C-20	IC802	G-20	Q701	G-18
D201	C-17	D801	H-19	IC803	E-20	Q702	D-19
D202	C-17	D802	F-18	IC901	H-23	Q703	A-19
D301	B-13	D803	F-19			Q704	A-19
D302	B-13	D805	G-20	Q101	G-13	Q705	A-20
D303	B-13	D807	G-20	Q102	C-16	Q706	B-20
D304	B-13	D808	H-17	Q103	B-14	Q707	B-20
D305	D-17	D809	H-17	Q104	F-15	Q708	C-21
D306	F-17	D810	H-17	Q105	E-15	Q709	D-21
D307	G-17	D814	F-17	Q201	G-12	Q803	F-18
D308	G-17	D815	F-17	Q202	B-14	Q807	H-19
D309	B-16	D901	H-26	Q203	B-13	Q808	G-18
D310	B-16	D902	H-26	Q204	F-14	Q809	G-18
D311	C-17	D903	H-26	Q205	E-15	Q810	G-18
D312	E-17			Q301	D-17	Q811	F-20
D313	F-17	IC81	G-8	Q302	G-16	Q812	F-20
D701	C-20	IC82	G-7	Q303	G-16	Q813	F-20
D702	C-20	IC301	G-12	Q304	G-16	Q814	H-20
D703	C-20	IC302	C-15	Q305	H-15		
		IC303	G-14				
D704	C-20			Q306	I-15		
D705	C-19	IC304	I-14	Q307	I-15		
D706	B-20	IC305	D-18	Q308	I-15		
D707	C-20	IC306	C-17	Q309	I-15		
D708	C-19	IC307	E-12	Q310	H-16		
		IC308	B-15				
D709	D-19			Q311	H-16		
D711	B-20	IC309	B-17	Q312	B-15		
D712	B-20	IC310	D-13	Q313	B-17		
D713	D-21	IC311	C-13	Q314	B-17		
D714	D-21	IC701	B-19	Q315	D-13		

Note:
 ○ : parts extracted from the component side.
 ◐ : Pattern on the side which is seen.

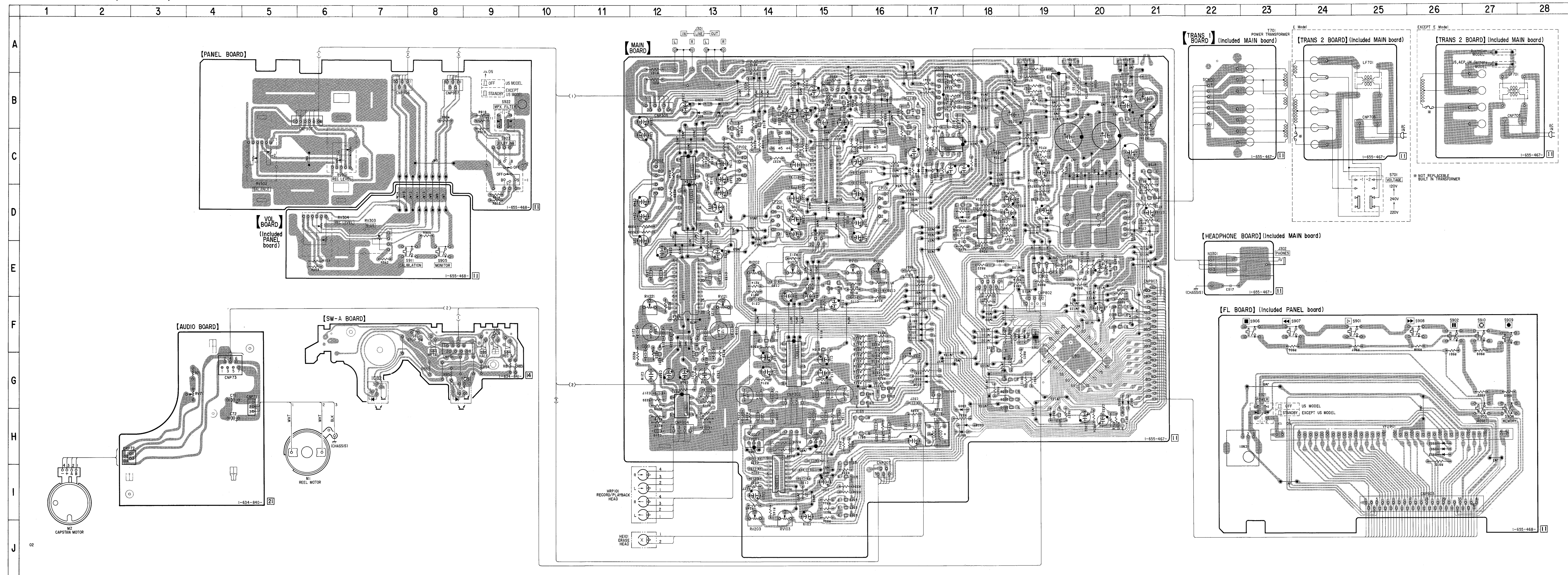

5-4. SCHEMATIC DIAGRAM (MAIN SECTION)

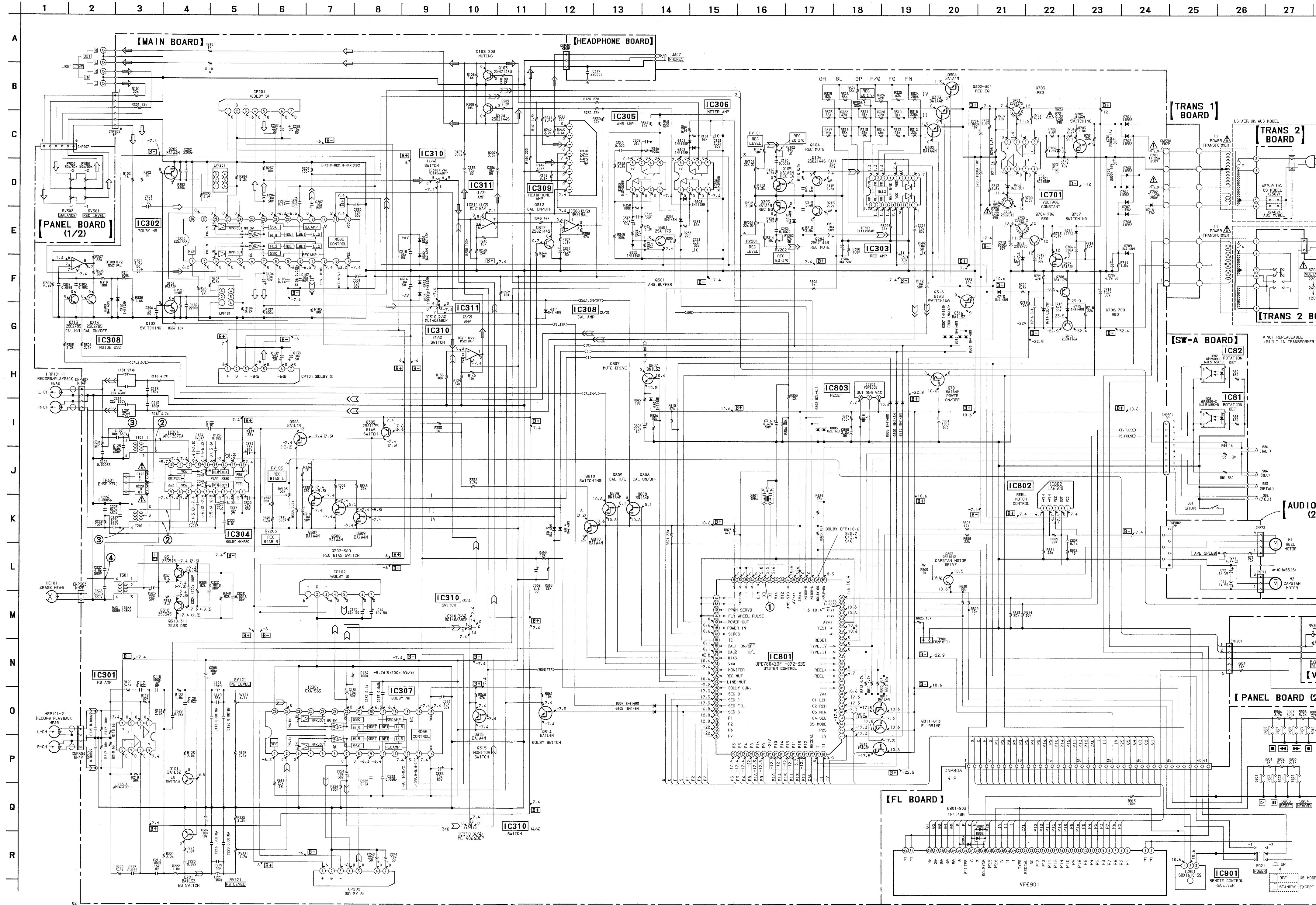

WAVEFORMS

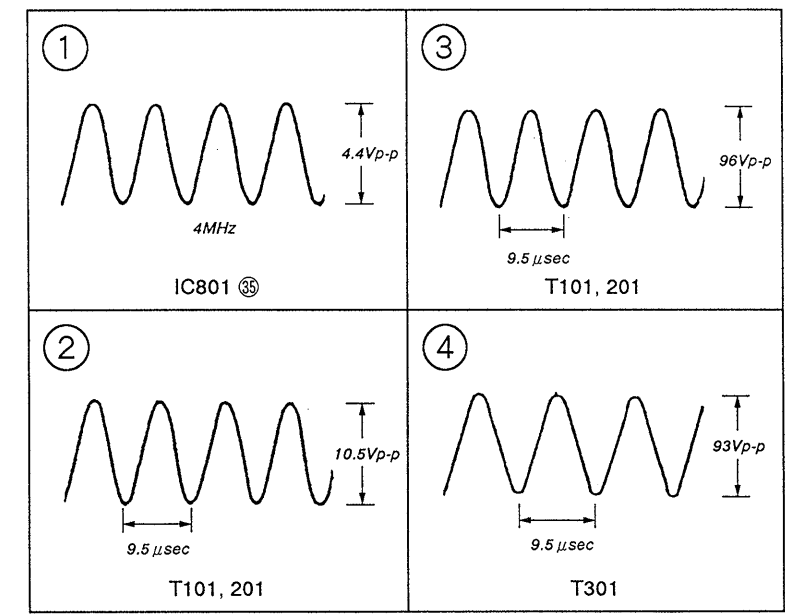

Note:

- All capacitors are in μ F unless otherwise noted. pF: μ F
- 50V or less are not indicated except for electrolytics and tantalums.
- All resistors are in Ω and $\frac{1}{4}W$ or less unless otherwise specified.
- % : indicates tolerance.
- Δ : internal component.

Note: The components identified by mark Δ or dotted line with mark Δ are critical for safety. Replace only with part number specified.

- B+** : B+ Line
- B-** : B- Line
- \square : adjustment for repair.
- Voltage and waveforms are dc with respect to ground under no-signal conditions.
- no mark : stop
- () : REC
- Voltages are taken with a VOM (Input impedance 10M Ω). Voltage variations may be noted due to normal production tolerances.
- Waveforms are taken with an oscilloscope. Voltage variations may be noted due to normal production tolerances.
- Circled numbers refer to waveforms.
- Signal path:
- \rightarrow : LINE
- \rightarrow : PB
- \rightarrow : REC

● IC BLOCK DIAGRAM

IC1 CXA1417Q

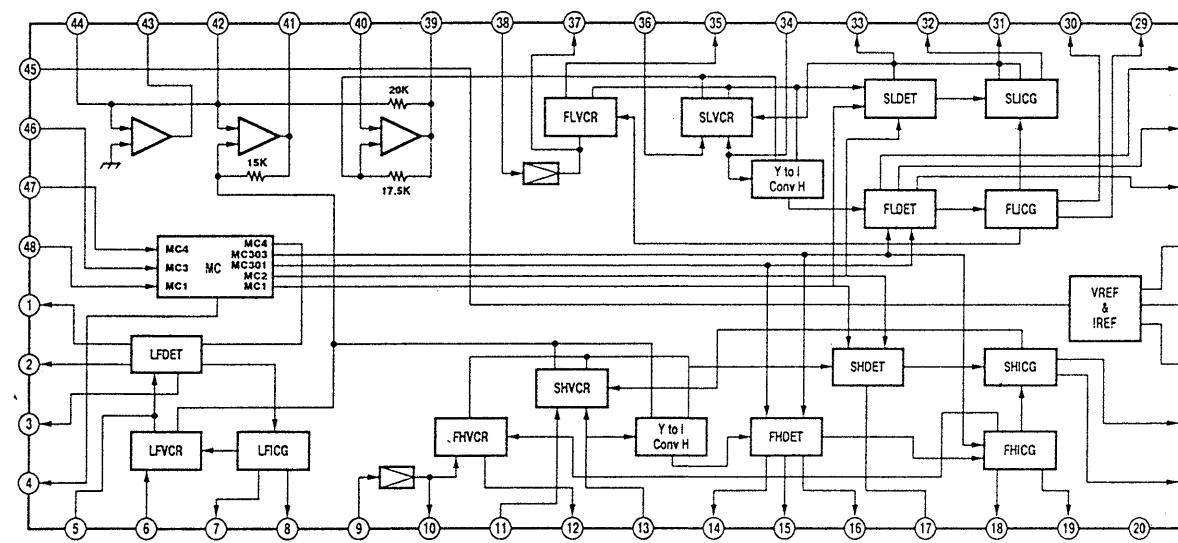

5-5. PRINTED WIRING BOARDS (DOLBY (S) BOARD)

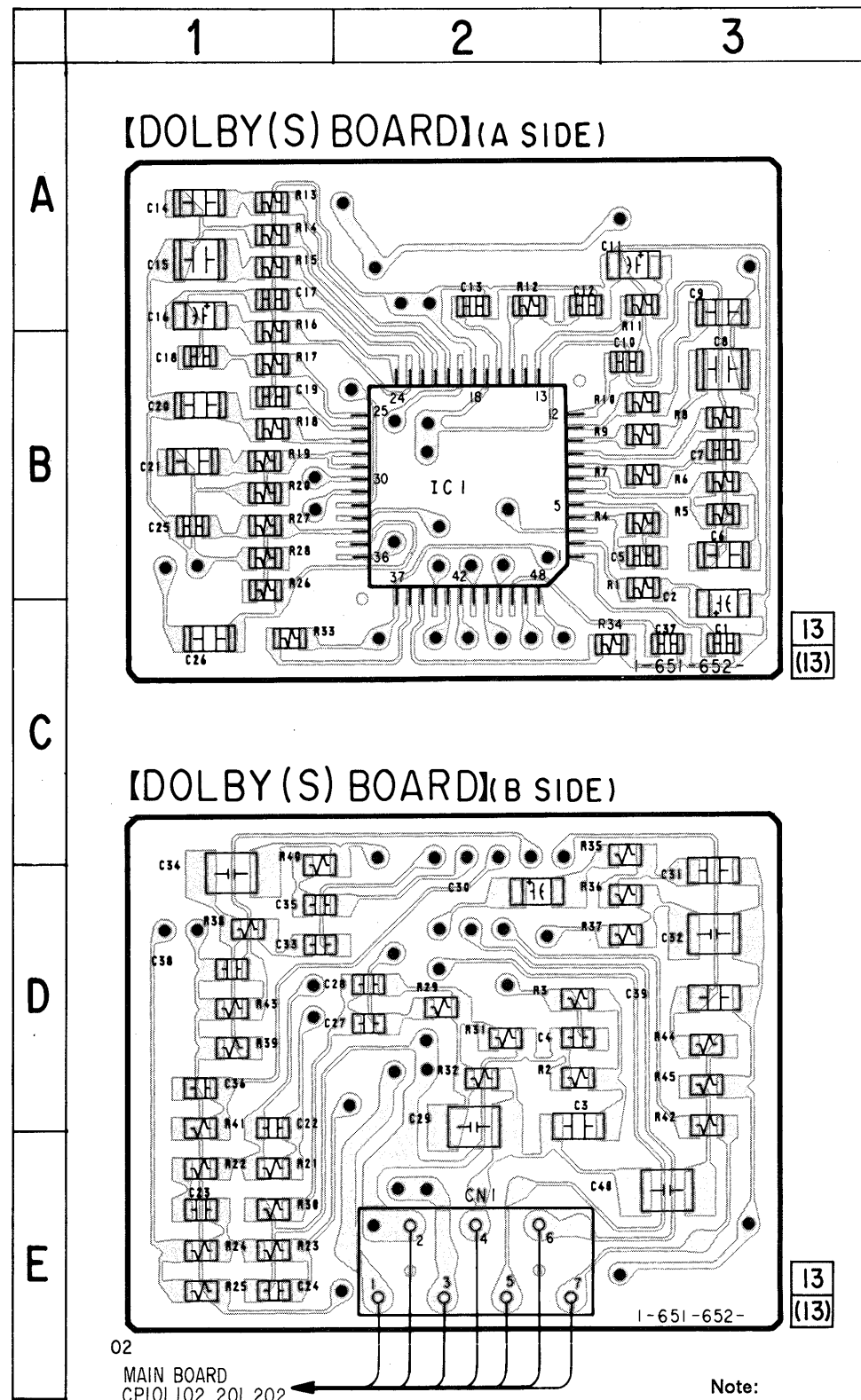

- Note:
- : parts extracted from the component side.
 - : Through hole.
 - ▨ : Pattern from the side which enables seeing. (The other layers' patterns are not indicated)

Caution :

Pattern face side : Parts on the pattern face side seen from (Conductor Side) the pattern face are indicated.
 Parts face side : Parts on the parts face side seen from the (Component side) parts face are indicated.

5-6. SCHEMATIC DIAGRAM (DOLBY (S) BOARD)

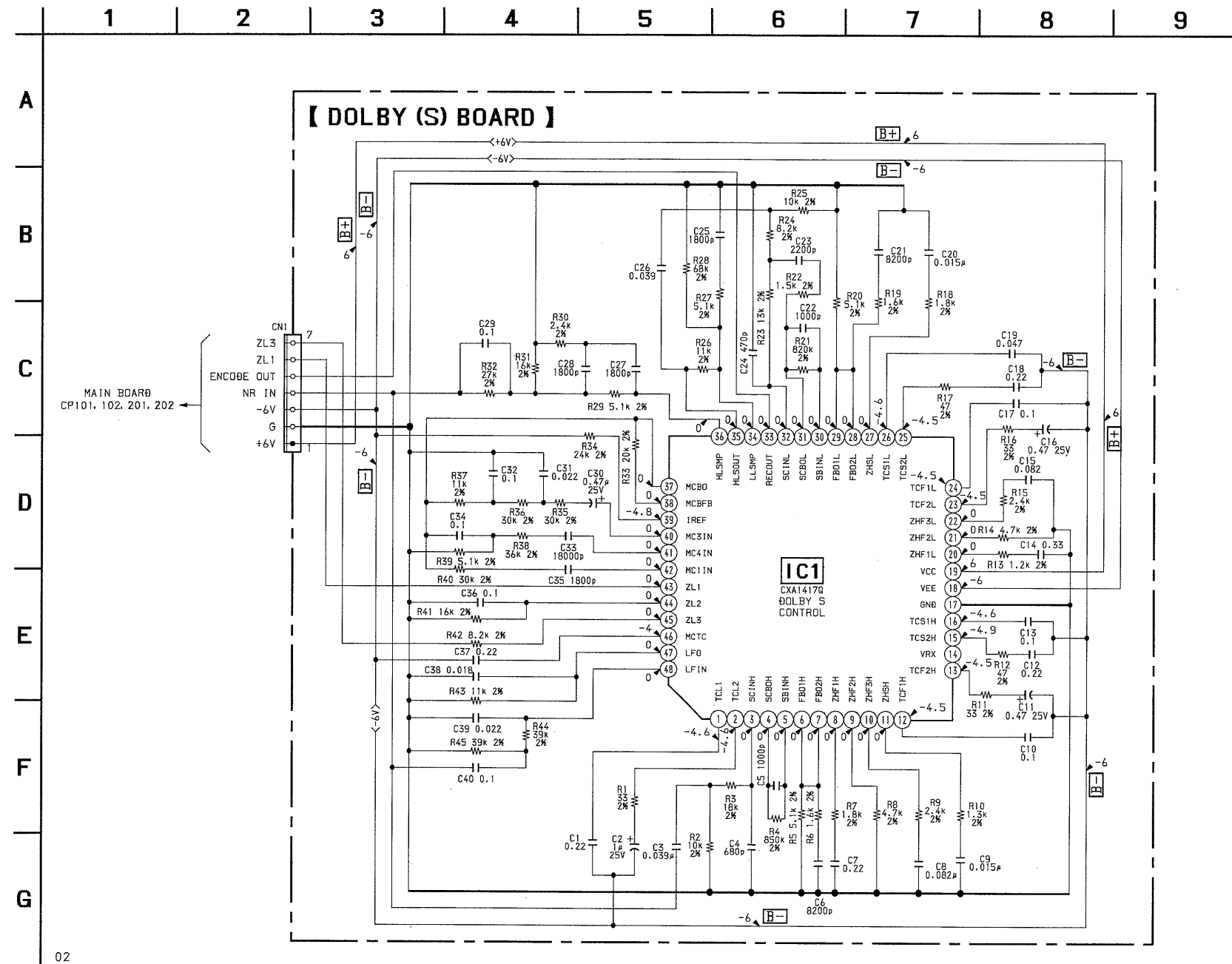

Note :

- All capacitors are in μF unless otherwise noted. pF : μF , μF 50WV or less are not indicated except for electrolytics and tantalums.
- All resistors are in Ω and 1/10W or less unless otherwise specified.
- % : indicates tolerance.
- **[B+]** : B+ Line
- **[B-]** : B- Line
- Voltage and waveforms are dc with respect to ground under no-signal conditions.
no mark : STOP
- Voltages are taken with a VOM (Input impedance 10M Ω). Voltage variations may be noted due to normal production tolerances.

SECTION 6 EXPLODED VIEWS

NOTE :

- -XX, -X mean standardized parts, so they may have some difference from the original one.
- The construction parts of an assembled part are indicated with a collation number in the remark column.
- Items marked " * " are not stocked since they are seldom required for routine service. Some delay should be anticipated when ordering these items.

- The mechanical parts with no reference number in the exploded views are not supplied.
- Hardware (# mark) list and accessories and packing materials are given in the last of this parts list.
- Abbreviation
G : German
AUS : Australian

The components identified by mark \triangle or dotted line with mark \triangle are critical for safety. Replace only with part number specified.

6-1. CHASSIS SECTION

- \blacktriangle A : TRANS 1 board
- \blacktriangle B : TRANS 2 board

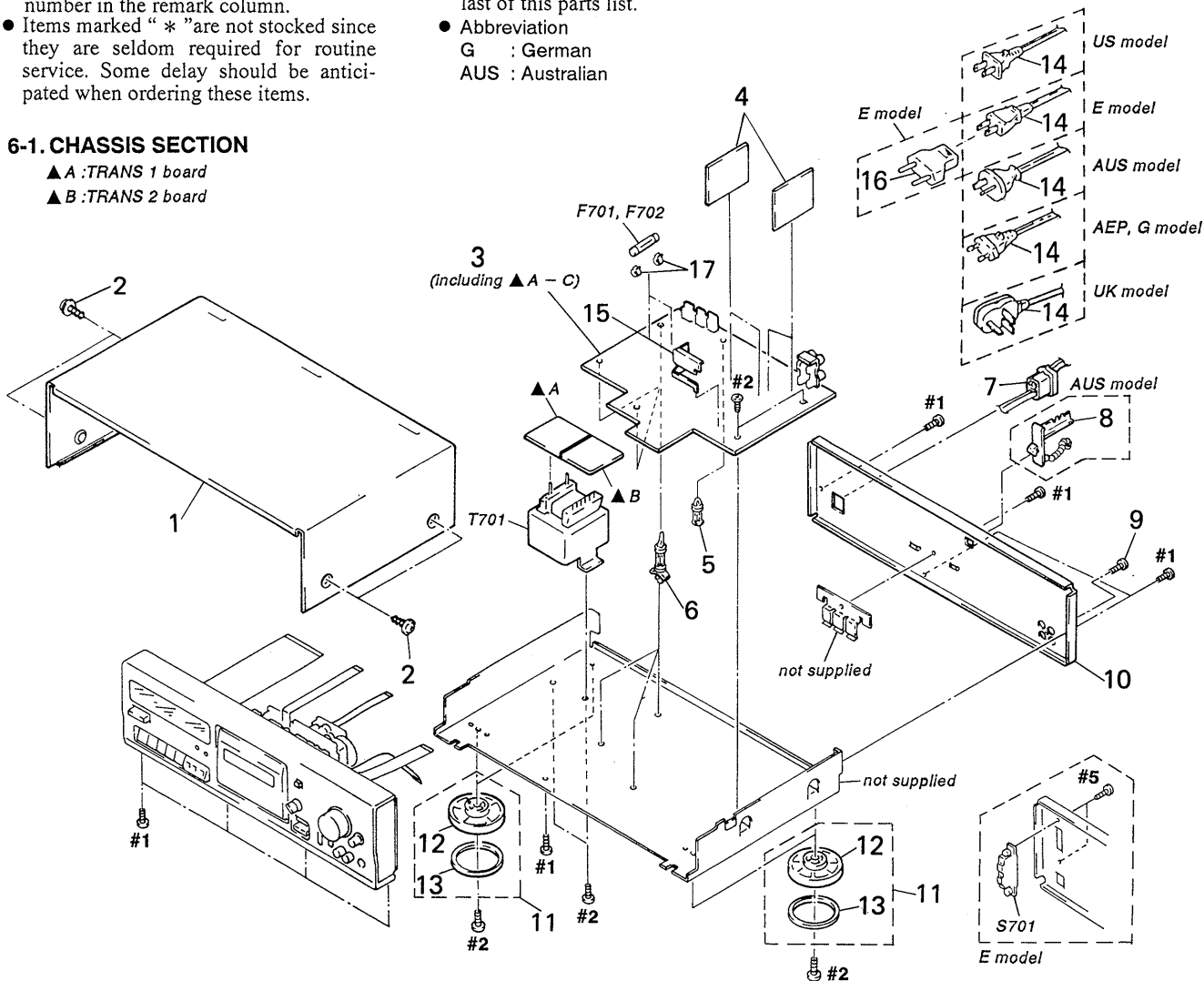

Ref. No.	Part No.	Description	Remark
* 1	4-943-088-41	CASE	
2	3-363-099-01	SCREW (CASE 3 TP2)	
* 3	A-2007-362-A	MAIN BOARD, COMPLETE (AEP, UK, G, US)	
* 3	A-2007-363-A	MAIN BOARD, COMPLETE (AUS)	
* 3	A-2007-364-A	MAIN BOARD, COMPLETE (E)	
* 4	A-2007-416-A	DOLBY (S) BOARD, COMPLE	
* 5	3-669-610-00	SPACER	
* 6	3-346-265-31	HOLDER, PC BOARD	
* 7	3-703-244-00	BUSHING (2104), CORD (AEP, UK, G, AUS)	
7	3-703-571-11	BUSHING (S) (4516), CORD (US, E)	
8	4-956-370-12	BAND, PLUG FIXED (AUS)	
9	3-704-515-01	SCREW (BV/RING)	
* 10	3-920-042-01	PANEL, BACK (US)	
* 10	3-920-042-11	PANEL, BACK (AEP, G)	
* 10	3-920-042-21	PANEL, BACK (UK)	
* 10	3-920-042-31	PANEL, BACK (E)	
* 10	3-920-042-41	PANEL, BACK (AUS)	
11	X-4941-291-1	FOOT ASSY (F58175S) (TC-KA1ES)	
11	X-4941-292-1	FOOT ASSY (F58175S) (TC-K561S)	

Ref. No.	Part No.	Description	Remark
12	3-318-688-31	FOOT (F58175S) (TC-K561S)	
12	3-318-688-51	FOOT (F58175S) (TC-KA1ES)	
13	4-923-836-21	CUSHION	
\triangle 14	1-558-945-21	CORD, POWER (POLAR. SPT-1) (US)	
\triangle 14	1-575-651-21	CORD, POWER (AEP, G)	
\triangle 14	1-696-027-11	CORD, POWER (E)	
\triangle 14	1-696-586-11	CORD, POWER (UK)	
\triangle 14	1-696-845-11	CORD, POWER (AUS)	
* 15	3-904-545-11	PLATE (PLAYBACK HD), SHIELD	
\triangle 16	1-569-007-11	ADAPTER, CONVERSION 2P (E)	
17	1-533-293-11	FUSE HOLDER	
\triangle F701	1-532-285-00	FUSE, TIME-LAG (TC-K561S)	
\triangle F701	1-532-741-11	FUSE, GLASS TUBE (TC-KA1ES)	
\triangle F702	1-532-285-00	FUSE, TIME-LAG (TC-K561S)	
\triangle F702	1-532-741-11	FUSE, GLASS TUBE (TC-KA1ES)	
\triangle S701	1-692-155-11	SELECTOR, POWER VOLTAGE (VOLTAGE) (E)	
\triangle T701	1-426-726-21	TRANSFORMER, POWER (US)	
\triangle T701	1-426-727-21	TRANSFORMER, POWER (AEP, UK, G, AUS)	
\triangle T701	1-426-728-21	TRANSFORMER, POWER (E)	

6-2. FRONT PANEL SECTION

▲ C : HEADPHONE board

■ D : DISPLAY board

■ E : VOLUME board

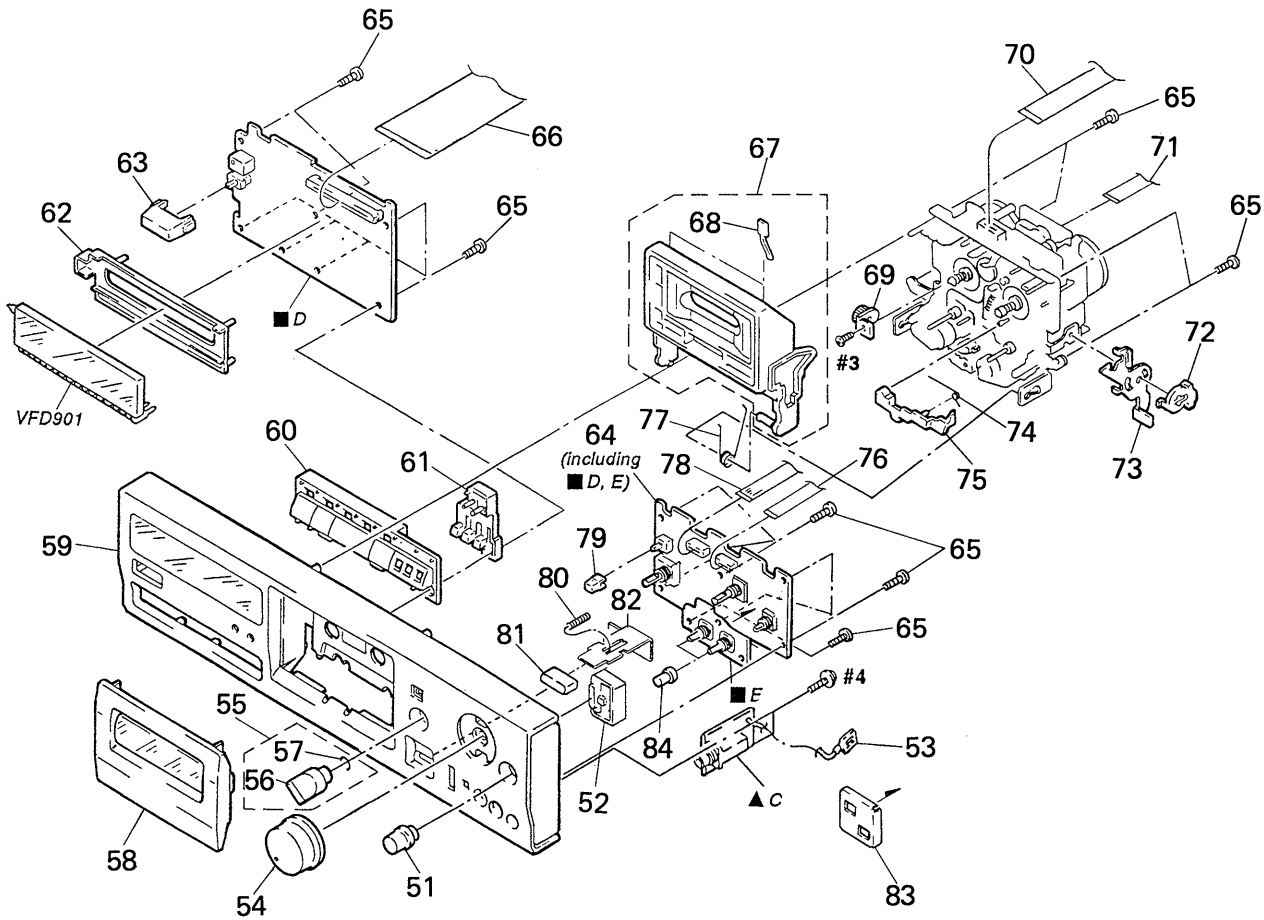

Ref. No.	Part No.	Description	Remark
51	X-3368-033-1	KNOB (RB) ASSY	
52	3-387-834-21	BUTTON (MBC)	
* 53	1-690-880-31	LEAD (WITH CONNECTOR)	
54	3-389-516-01	KNOB (REC)	
55	X-3368-032-1	KNOB ASSY	
56	3-350-440-11	SPRING, RING	
57	4-908-097-21	KNOB	
58	X-3369-570-1	LID ASSY, CASSETTE (TC-KA1ES)	
58	X-3369-575-1	LID ASSY, CASSETTE (TC-K561S)	
59	X-3369-573-1	PANEL ASSY, FRONT (TC-KA1ES)	
59	X-3369-574-1	PANEL ASSY, FRONT (TC-K561S)	
60	3-386-247-11	BUTTON (FW)	
61	3-386-248-11	BUTTON (RE)	
* 62	3-386-245-01	HOLDER (FL)	
63	3-354-932-01	BUTTON (POWER)	
* 64	A-2007-361-A	PANEL BOARD, COMPLETE	
65	4-951-620-01	SCREW (2.6×8), +BVTP	
66	1-769-406-11	WIRE (FLAT TYPE) (41 CORE)	
67	A-2004-357-A	HOLDER (R) ASSY, CASSETTE	

Ref. No.	Part No.	Description	Remark
68	3-308-823-11	DETENT, CASSETTE	
69	3-354-963-01	DAMPER	
70	1-751-732-11	WIRE (FLAT TYPE) (9 CORE)	
71	1-751-733-11	WIRE (FLAT TYPE) (7 CORE)	
72	3-354-957-01	JOINT (LOCK LEVER)	
* 73	3-354-954-01	LEVER (LOCK LEVER R)	
74	3-354-962-01	SPRING (EJ SAFTY SPRING R)	
75	3-354-956-01	LEVER (EJ SAFTY LEVER R)	
76	1-769-431-11	WIRE (FLAT TYPE) (5 CORE)	
77	3-354-960-01	SPRING (LOADING R), TORSION	
78	1-751-734-11	WIRE (FLAT TYPE) (5 CORE)	
79	3-380-952-21	BUTTON	
80	3-359-906-11	SPRING, COMPRESSION	
81	3-387-830-11	BUTTON (EJECT)	
82	3-387-833-11	SLIDER (EJECT)	
* 83	3-904-544-11	PLATE (VOL), SHIELD	
84	3-367-431-01	KNOB (BAL)	
VFD901	1-517-163-11	INDICATOR TUBE, FLUORESCENT	

6-3. MECHANISM SECTION 1
(TCM-190VB14)

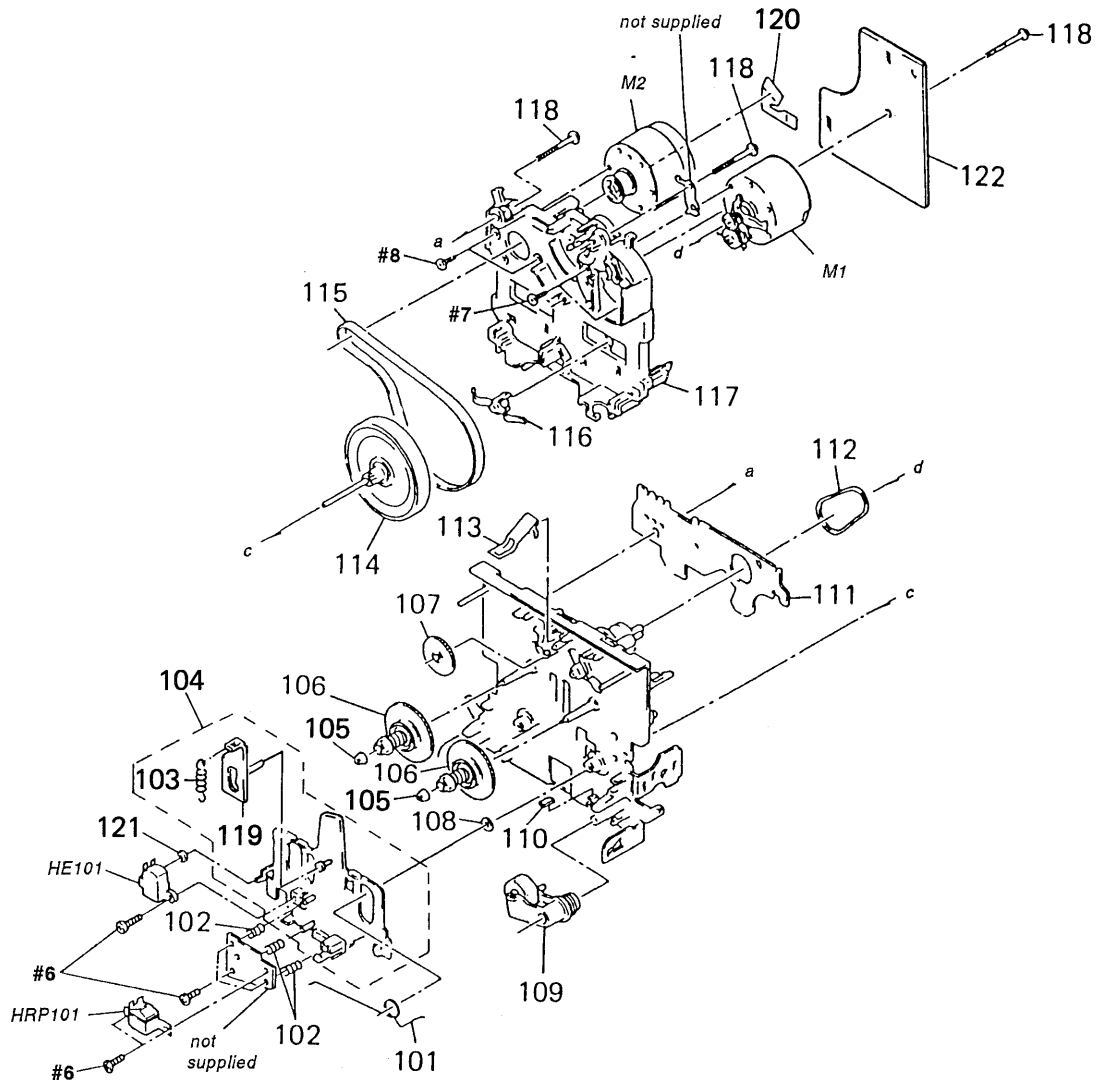

Ref.No.	Part No.	Description	Remark	Ref.No.	Part No.	Description	Remark
101	3-911-014-01	SPRING, TORSION		114	X-3368-368-1	FLYWHEEL (FWD) COMPLETE ASSY	
102	3-356-659-11	SPRING (RPH), COMPRESSION		115	3-359-467-01	BELT (1 WAY FLAT BELT)	
103	3-363-868-01	SPRING (HEAD CHASSIS), TENSION		116	3-575-321-00	RETAINER, THRUST, CAPSTAN	
* 104	X-3369-024-1	SLIDER (HEAD CHASSIS) ASSY		117	3-911-007-11	BASE (THRUST RETAINER), FITTING	
105	3-362-308-01	CAP (REEL)		118	3-359-414-01	SCREW (+PTPH 2x23)	
106	X-3366-971-1	TABLE ASSY (B), REEL		* 119	X-3368-865-1	SLIDER (LIMITER) ASSY	
107	3-359-424-01	GEAR (REV GEAR)		120	1-638-983-11	MOTOR FLEXIBLE BOARD	
108	3-356-713-01	WASHER		121	3-701-437-11	WASHER	
109	X-3366-047-1	LEVER (PINCH F) ASSY		* 122	1-634-840-21	AUDIO BOARD	
110	3-359-469-01	SPACER		HE101	1-543-673-11	HEAD, MAGNETIC (ERASE)	
* 111	1-634-841-14	SW-A BOARD		HRP101	1-543-733-11	HEAD, MAGNETIC (RECORD/PLAYBACK)	
112	3-359-466-01	BELT (FR), SQUARE		M1	X-3363-501-2	MOTOR ASSY (REEL)	
113	3-359-430-01	SPRING (CASSETTE RETAINER), LEAF		M2	X-3368-855-1	MOTOR ASSY (CAPSTAN)	

6-4. MECHANISM SECTION 2
(TCM-190VB14)

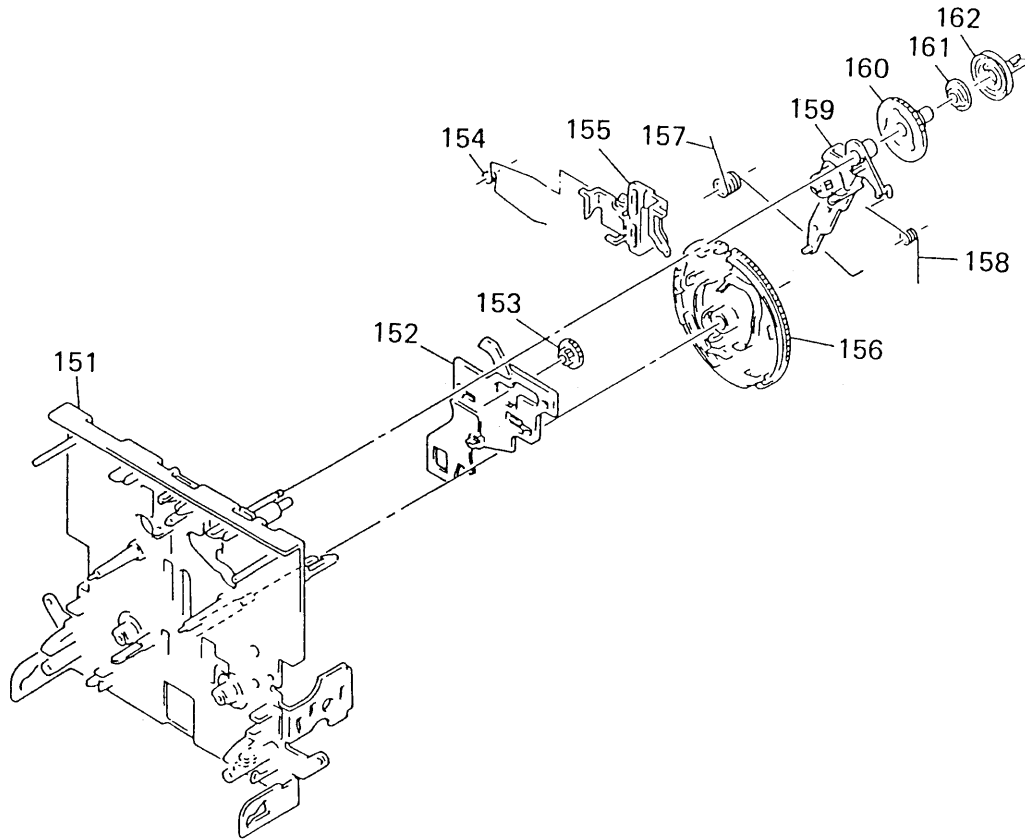

<u>Ref. No.</u>	<u>Part No.</u>	<u>Description</u>	<u>Remark</u>	<u>Ref. No.</u>	<u>Part No.</u>	<u>Description</u>	<u>Remark</u>
151	X-3368-719-2	CHASSIS (ONE) ASSY, MECHANICAL		157	3-359-456-01	SPRING (TRIGGER SPRING), TORSION	
152	3-359-415-11	SLIDER (TRIGGER SLIDER)		158	3-924-185-11	SPRING (FR ARM), TORSION	
153	3-359-448-01	GEAR (TRIGGER)		159	X-3366-569-1	ARM ASSY, FR	
154	3-359-454-01	SPRING, TORSION		160	3-359-419-11	GEAR (FR GEAR)	
155	3-359-429-11	SLIDER (BRAKE PLATE)		161	3-359-421-01	CLUTCH (REEL DISK)	
156	3-359-420-01	GEAR (CAM GEAR)		162	3-359-418-01	PULLEY (FR PULLEY)	

SECTION 7 ELECTRICAL PARTS LIST

AUDIO

DOLBY (S)

NOTE :

- Due to standardization, replacements in the parts list may be different from the parts specified in the diagrams or the components used on the set.
- -XX, -X mean standardized parts, so they may have some difference from the original one.
- RESISTORS
All resistors are in ohms
METAL : Metal-film resistor
METAL OXIDE : Metal oxide-film resistor
F : nonflammable

- Items marked " * " are not stocked since they are seldom required for routine service. Some delay should be anticipated when ordering these items.

● SEMICONDUCTORS

In each case, u : μ , for example :

uA..... : μ A..... , uPA..... : μ PA.....

uPB..... : μ PB..... , uPC..... : μ PC.....

uPD..... : μ PD.....

● CAPACITORS

uF : μ F

● COILS

uH : μ H

● Abbreviation

G : German

AUS : Australian

The components identified by mark Δ or dotted line with mark Δ are critical for safety. Replace only with part number specified.

When indicating parts by reference number, please include the board.

Ref. No.	Part No.	Description	Remark	Ref. No.	Part No.	Description	Remark
*	1-634-840-21	AUDIO BOARD *****		C16	1-135-145-11	TANTALUM CHIP 0.47uF	10% 35V
		< CAPACITOR >		C17	1-165-319-11	CERAMIC CHIP 0.1uF	50V
C71	1-124-903-11	ELECT 1uF	20% 50V	C18	1-164-222-11	CERAMIC CHIP 0.22uF	25V
C72	1-124-903-11	ELECT 1uF	20% 50V	C19	1-163-035-00	CERAMIC CHIP 0.047uF	50V
		< CONNECTOR >		C20	1-104-553-11	FILM CHIP 0.015uF	5% 16V
* CNP71	1-564-705-11	PIN, CONNECTOR (SMALL TYPE) 3P		C21	1-164-717-11	CERAMIC CHIP 0.0082uF	5% 50V
* CNP72	1-764-902-11	CONNECTOR, FFC/FPC 4P		C22	1-163-009-11	CERAMIC CHIP 0.001uF	10% 50V
* CNP73	1-568-826-11	SOCKET, CONNECTOR 7P		C23	1-164-161-11	CERAMIC CHIP 0.0022uF	10% 100V
		< RESISTOR >		C24	1-163-005-11	CERAMIC CHIP 470PF	10% 50V
R71	1-249-430-11	CARBON 12K 5% 1/4W		C25	1-163-012-00	CERAMIC CHIP 0.0018uF	10% 50V
		< VARIABLE RESISTOR >		C26	1-104-558-11	FILM CHIP 0.039uF	5% 16V
RV71	1-238-599-11	RES, ADJ, CARBON 4.7K (TAPE SPEED)		C27	1-163-012-00	CERAMIC CHIP 0.0018uF	10% 50V
*****				C28	1-163-012-00	CERAMIC CHIP 0.0018uF	10% 50V
* A-2007-416-A	DOLBY (S) BOARD, COMPLETE *****			C29	1-104-563-11	FILM CHIP 0.1uF	5% 16V
		< CAPACITOR >		C30	1-135-145-11	TANTALUM CHIP 0.47uF	10% 35V
C1	1-164-222-11	CERAMIC CHIP 0.22uF	25V	C31	1-104-555-11	FILM CHIP 0.022uF	5% 16V
C2	1-135-177-21	TANTALUM CHIP 1uF	20% 20V	C32	1-104-563-11	FILM CHIP 0.1uF	5% 16V
C3	1-104-558-11	FILM CHIP 0.039uF	5% 16V	C33	1-163-024-00	CERAMIC CHIP 0.018uF	10% 50V
C4	1-163-007-11	CERAMIC CHIP 680PF	10% 50V	C34	1-104-563-11	FILM CHIP 0.1uF	5% 16V
C5	1-163-009-11	CERAMIC CHIP 0.001uF	10% 50V	C35	1-163-012-00	CERAMIC CHIP 0.0018uF	10% 50V
C6	1-164-717-11	CERAMIC CHIP 0.0082uF	5% 50V	C36	1-165-319-11	CERAMIC CHIP 0.1uF	50V
C7	1-164-222-11	CERAMIC CHIP 0.22uF	25V	C37	1-164-222-11	CERAMIC CHIP 0.22uF	25V
C8	1-104-562-11	FILM CHIP 0.082uF	5% 16V	C38	1-163-024-00	CERAMIC CHIP 0.018uF	10% 50V
C9	1-104-553-11	FILM CHIP 0.015uF	5% 16V	C39	1-104-555-11	FILM CHIP 0.022uF	5% 16V
C10	1-165-319-11	CERAMIC CHIP 0.1uF	50V	C40	1-104-563-11	FILM CHIP 0.1uF	5% 16V
C11	1-135-145-11	TANTALUM CHIP 0.47uF	10% 35V			< CONNECTOR >	
C12	1-164-222-11	CERAMIC CHIP 0.22uF	25V	CN1	1-695-092-11	SOCKET, CONNECTOR 7P	
C13	1-165-319-11	CERAMIC CHIP 0.1uF	50V			< IC >	
C14	1-162-568-11	CERAMIC CHIP 0.33uF	10% 16V	IC1	8-752-056-51	IC CXA1417Q	
C15	1-104-562-11	FILM CHIP 0.082uF	5% 16V			< RESISTOR >	
R1	1-216-615-11	METAL CHIP 33	0.5% 1/10W	R1	1-216-615-11	METAL CHIP 33	0.5% 1/10W
R2	1-208-806-11	METAL GLAZE 10K	2% 1/10W	R2	1-208-806-11	METAL GLAZE 10K	2% 1/10W
R3	1-208-812-11	METAL GLAZE 18K	2% 1/10W	R3	1-208-812-11	METAL GLAZE 18K	2% 1/10W
R4	1-216-119-00	METAL CHIP 820K	5% 1/10W	R4	1-216-119-00	METAL CHIP 820K	5% 1/10W
R5	1-208-799-11	METAL GLAZE 5.1K	2% 1/10W	R5	1-208-799-11	METAL GLAZE 5.1K	2% 1/10W

DOLBY (S)**MAIN****HEADPHONE****TRANS 1****TRANS 2**

Ref. No.	Part No.	Description	Remark		
R6	1-208-787-11	METAL GLAZE	1.6K	2%	1/10W
R7	1-216-657-11	METAL CHIP	1.8K	0.5%	1/10W
R8	1-216-667-11	METAL CHIP	4.7K	0.5%	1/10W
R9	1-208-791-11	METAL GLAZE	2.4K	2%	1/10W
R10	1-216-052-00	METAL CHIP	1.3K	5%	1/10W
R11	1-216-615-11	METAL CHIP	33	0.5%	1/10W
R12	1-216-619-11	METAL CHIP	47	0.5%	1/10W
R13	1-208-784-11	METAL GLAZE	1.2K	2%	1/10W
R14	1-216-667-11	METAL CHIP	4.7K	0.5%	1/10W
R15	1-208-791-11	METAL GLAZE	2.4K	2%	1/10W
R16	1-216-615-11	METAL CHIP	33	0.5%	1/10W
R17	1-216-619-11	METAL CHIP	47	0.5%	1/10W
R18	1-216-657-11	METAL CHIP	1.8K	0.5%	1/10W
R19	1-208-787-11	METAL GLAZE	1.6K	2%	1/10W
R20	1-208-799-11	METAL GLAZE	5.1K	2%	1/10W
R21	1-216-119-00	METAL CHIP	820K	5%	1/10W
R22	1-216-655-11	METAL CHIP	1.5K	0.5%	1/10W
R23	1-216-678-11	METAL CHIP	13K	0.5%	1/10W
R24	1-216-673-11	METAL CHIP	8.2K	0.5%	1/10W
R25	1-208-806-11	METAL GLAZE	10K	2%	1/10W
R26	1-216-676-11	METAL CHIP	11K	0.5%	1/10W
R27	1-208-799-11	METAL GLAZE	5.1K	2%	1/10W
R28	1-216-695-11	METAL CHIP	68K	0.5%	1/10W
R29	1-208-799-11	METAL GLAZE	5.1K	2%	1/10W
R30	1-208-791-11	METAL GLAZE	2.4K	2%	1/10W
R31	1-208-811-11	METAL GLAZE	16K	2%	1/10W
R32	1-216-685-11	METAL CHIP	27K	0.5%	1/10W
R33	1-208-813-11	METAL GLAZE	20K	2%	1/10W
R34	1-216-684-11	METAL CHIP	24K	0.5%	1/10W
R35	1-208-817-11	METAL GLAZE	30K	2%	1/10W
R36	1-208-817-11	METAL GLAZE	30K	2%	1/10W
R37	1-216-676-11	METAL CHIP	11K	0.5%	1/10W
R38	1-208-819-11	METAL GLAZE	36K	2%	1/10W
R39	1-208-799-11	METAL GLAZE	5.1K	2%	1/10W
R40	1-208-817-11	METAL GLAZE	30K	2%	1/10W
R41	1-208-811-11	METAL GLAZE	16K	2%	1/10W
R42	1-216-673-11	METAL CHIP	8.2K	0.5%	1/10W
R43	1-216-676-11	METAL CHIP	11K	0.5%	1/10W
R44	1-216-689-11	METAL CHIP	39K	0.5%	1/10W
R45	1-216-689-11	METAL CHIP	39K	0.5%	1/10W

Ref. No.	Part No.	Description	Remark		
*	A-2007-362-A	MAIN BOARD, COMPLETE (AEP, UK, G, US)			
*	A-2007-363-A	MAIN BOARD, COMPLETE (AUS)			
*	A-2007-364-A	MAIN BOARD, COMPLETE (E)			

		HEADPHONE BOARD			

		TRANS 1 BOARD			

		TRANS 2 BOARD			

	1-533-293-11	FUSE HOLDER			
*	1-690-880-31	LEAD (WITH CONNECTOR)			
		< CAPACITOR >			
C101	1-126-963-11	ELECT	4.7uF	20%	50V
C102	1-162-302-11	CERAMIC	0.0022uF	20%	16V
C104	1-124-907-11	ELECT	10uF	20%	50V
C105	1-136-165-00	FILM	0.1uF	5%	50V
C106	1-136-163-00	FILM	0.068uF	5%	50V
C107	1-124-907-11	ELECT	10uF	20%	50V
C110	1-136-175-00	FILM	0.68uF	5%	50V
C111	1-124-907-11	ELECT	10uF	20%	50V
C112	1-124-907-11	ELECT	10uF	20%	50V
C113	1-137-428-11	FILM	180PF	5%	50V
C114	1-136-935-11	FILM	22PF	5%	630V
C115	1-137-429-11	FILM	270PF	5%	50V
C116	1-137-434-11	FILM	0.0018uF	5%	50V
C117	1-136-157-00	FILM	0.022uF	5%	50V
C118	1-107-714-11	ELECT	10uF	20%	16V
C119	1-102-518-11	CERAMIC	33PF	5%	50V
C120	1-137-441-11	FILM	0.027uF	5%	50V
C121	1-124-925-11	ELECT	2.2uF	20%	100V
C122	1-136-153-00	FILM	0.01uF	5%	50V
C123	1-136-157-00	FILM	0.022uF	5%	50V
C124	1-136-161-00	FILM	0.047uF	5%	50V
C125	1-136-803-11	FILM	560PF	5%	630V
C126	1-137-431-11	FILM	560PF	5%	50V
C127	1-136-433-11	FILM	100PF	5%	630V
C128	1-137-434-11	FILM	0.0018uF	5%	50V
C130	1-137-366-11	FILM	0.0022uF	5%	50V
C131	1-124-907-11	ELECT	10uF	20%	50V
C132	1-136-165-00	FILM	0.1uF	5%	50V
C133	1-136-163-00	FILM	0.068uF	5%	50V
C136	1-124-907-11	ELECT	10uF	20%	50V
C137	1-124-916-11	ELECT	22uF	20%	63V
C138	1-124-907-11	ELECT	10uF	20%	50V
C140	1-124-916-11	ELECT	22uF	20%	63V
C141	1-124-907-11	ELECT	10uF	20%	50V
C201	1-126-963-11	ELECT	4.7uF	20%	50V

MAIN

HEADPHONE

TRANS 1

TRANS 2

Ref. No.	Part No.	Description	Remark			Ref. No.	Part No.	Description	Remark		
C202	1-162-302-11	CERAMIC	0.0022uF	20%	16V	C317	1-161-494-00	CERAMIC	0.022uF		25V
C204	1-124-907-11	ELECT	10uF	20%	50V	C319	1-124-907-11	ELECT	10uF	20%	50V
C205	1-136-165-00	FILM	0.1uF	5%	50V	C320	1-126-967-11	ELECT	47uF	20%	35V
C206	1-136-163-00	FILM	0.068uF	5%	50V	C321	1-126-967-11	ELECT	47uF	20%	35V
C207	1-124-907-11	ELECT	10uF	20%	50V	C322	1-106-349-00	MYLAR	0.0018uF	5%	100V
C210	1-136-175-00	FILM	0.68uF	5%	50V	C323	1-106-349-00	MYLAR	0.0018uF	5%	100V
C211	1-124-907-11	ELECT	10uF	20%	50V	C324	1-106-359-00	MYLAR	4700PF	5%	200V
C212	1-124-907-11	ELECT	10uF	20%	50V	C325	1-124-916-11	ELECT	22uF	20%	63V
C213	1-137-428-11	FILM	180PF	5%	50V	C326	1-136-558-11	FILM	0.0039uF	5%	630V
C214	1-136-935-11	FILM	22PF	5%	630V	C327	1-107-584-11	CERAMIC	4PF		0.25PF 500V
C215	1-137-429-11	FILM	270PF	5%	50V	C329	1-161-494-00	CERAMIC	0.022uF		25V
C216	1-137-434-11	FILM	0.0018uF	5%	50V	C330	1-124-907-11	ELECT	10uF	20%	50V
C217	1-136-157-00	FILM	0.022uF	5%	50V	C331	1-124-907-11	ELECT	10uF	20%	50V
C218	1-107-714-11	ELECT	10uF	20%	16V	C332	1-124-925-11	ELECT	2.2uF	20%	100V
C219	1-102-518-11	CERAMIC	33PF	5%	50V	C333	1-124-907-11	ELECT	10uF	20%	50V
C220	1-137-441-11	FILM	0.027uF	5%	50V	C334	1-124-907-11	ELECT	10uF	20%	50V
C221	1-124-925-11	ELECT	2.2uF	20%	100V	C701	1-126-936-11	ELECT	3300uF	20%	16V
C222	1-136-153-00	FILM	0.01uF	5%	50V	C702	1-126-936-11	ELECT	3300uF	20%	16V
C223	1-136-157-00	FILM	0.022uF	5%	50V	C703	1-104-666-11	ELECT	220uF	20%	10V
C224	1-136-161-00	FILM	0.047uF	5%	50V	C704	1-126-926-11	ELECT	1000uF	20%	10V
C225	1-136-803-11	FILM	560PF	5%	630V	C705	1-126-926-11	ELECT	1000uF	20%	10V
C226	1-137-431-11	FILM	560PF	5%	50V	C706	1-124-120-11	ELECT	220uF	20%	25V
C227	1-136-433-11	FILM	100PF	5%	630V	C707	1-126-963-11	ELECT	4.7uF	20%	50V
C228	1-137-434-11	FILM	0.0018uF	5%	50V	C712	1-124-903-11	ELECT	1uF	20%	50V
C230	1-137-366-11	FILM	0.0022uF	5%	50V	C713	1-126-926-11	ELECT	1000uF	20%	10V
C231	1-124-907-11	ELECT	10uF	20%	50V	C714	1-124-122-11	ELECT	100uF	20%	50V
C232	1-136-165-00	FILM	0.1uF	5%	50V	C715	1-126-967-11	ELECT	47uF	20%	35V
C233	1-136-163-00	FILM	0.068uF	5%	50V	C716	1-164-159-11	CERAMIC	0.1uF		50V
C236	1-124-907-11	ELECT	10uF	20%	50V	C801	1-124-443-00	ELECT	100uF	20%	10V
C237	1-124-916-11	ELECT	22uF	20%	63V	C802	1-104-666-11	ELECT	220uF	20%	10V
C238	1-124-907-11	ELECT	10uF	20%	50V	C805	1-164-159-11	CERAMIC	0.1uF		50V
C240	1-124-916-11	ELECT	22uF	20%	63V	C808	1-126-962-11	ELECT	3.3uF	20%	50V
C241	1-124-907-11	ELECT	10uF	20%	50V						
C301	1-124-907-11	ELECT	10uF	20%	50V			< CONNECTOR >			
C302	1-124-907-11	ELECT	10uF	20%	50V						
C303	1-137-436-11	FILM	0.0039uF	5%	50V	* CNP301	1-564-337-00	PIN, CONNECTOR	3P		
C304	1-124-907-11	ELECT	10uF	20%	50V	* CNP302	1-560-062-00	PIN, CONNECTOR	4P		
C305	1-136-164-00	FILM	0.082uF	5%	50V	* CNP303	1-560-060-00	PIN, CONNECTOR	2P		
C306	1-124-903-11	ELECT	1uF	20%	50V	* CNP304	1-560-062-00	PIN, CONNECTOR	4P		
C307	1-124-443-00	ELECT	100uF	20%	10V	* CNP305	1-691-462-11	PIN, CONNECTOR (PC BOARD)	6P		
C308	1-124-443-00	ELECT	100uF	20%	10V	* CNP306	1-568-824-11	SOCKET, CONNECTOR	5P		
C309	1-162-217-31	CERAMIC	56PF	5%	50V	* CNP307	1-568-824-11	SOCKET, CONNECTOR	5P		
C310	1-161-494-00	CERAMIC	0.022uF		25V	CNP701	1-564-510-11	PLUG, CONNECTOR	7P		
C311	1-124-925-11	ELECT	2.2uF	20%	100V	* CNP705	1-580-230-31	PIN, CONNECTOR (PC BOARD)	2P		
C312	1-162-217-31	CERAMIC	56PF	5%	50V	* CNP801	1-568-828-11	SOCKET, CONNECTOR	9P		
C313	1-124-925-11	ELECT	2.2uF	20%	100V	* CNP802	1-568-826-11	SOCKET, CONNECTOR	7P		
C314	1-124-907-11	ELECT	10uF	20%	50V	CNP803	1-770-246-11	SOCKET, CONNECTOR	41P		
C315	1-124-907-11	ELECT	10uF	20%	50V	CP101	1-695-087-11	PIN, CONNECTOR (PC BOARD)	7P		
C316	1-124-902-00	ELECT	0.47uF	20%	50V	CP102	1-695-087-11	PIN, CONNECTOR (PC BOARD)	7P		
						CP201	1-695-087-11	PIN, CONNECTOR (PC BOARD)	7P		

MAIN

HEADPHONE

TRANS 1

TRANS 2

Ref. No.	Part No.	Description	Remark
CP202	1-695-087-11	PIN, CONNECTOR (PC BOARD) 7P	
		< DIODE >	
D101	8-719-987-63	DIODE 1N4148M	
D102	8-719-987-63	DIODE 1N4148M	
D201	8-719-987-63	DIODE 1N4148M	
D202	8-719-987-63	DIODE 1N4148M	
D301-313	8-719-987-63	DIODE 1N4148M	
D701-704			
	8-719-024-99	DIODE 11ES2-NTA2B	
D705	8-719-933-33	DIODE HZS6A1L	
D706	8-719-933-33	DIODE HZS6A1L	
D707	8-719-024-99	DIODE 11ES2-NTA2B	
D708	8-719-024-99	DIODE 11ES2-NTA2B	
D709	8-719-987-63	DIODE 1N4148M	
D711	8-719-000-78	DIODE UZL-7L2	
D712	8-719-024-99	DIODE 11ES2-NTA2B	
D713	8-719-987-63	DIODE 1N4148M	
D714	8-719-000-93	DIODE UZL-7H1	
D715	8-719-987-63	DIODE 1N4148M	
D718	8-719-024-99	DIODE 11ES2-NTA2B	
D801	8-719-987-63	DIODE 1N4148M	
D802	8-719-933-33	DIODE HZS6A1L	
D803	8-719-933-33	DIODE HZS6A1L	
D805	8-719-987-63	DIODE 1N4148M	
D807	8-719-987-63	DIODE 1N4148M	
D808	8-719-987-63	DIODE 1N4148M	
D809	8-719-987-63	DIODE 1N4148M	
D810	8-719-987-63	DIODE 1N4148M	
D814	8-719-987-63	DIODE 1N4148M	
D815	8-719-987-63	DIODE 1N4148M	
		< IC >	
IC301	8-759-111-44	IC uPC4570C-1	
IC302	8-752-066-35	IC CXA1563S	
IC303	8-752-060-64	IC CXA1198AP	
IC304	8-759-106-56	IC uPC1297CA	
IC305	8-759-634-51	IC M5218AP	
IC306	8-759-634-51	IC M5218AP	
IC307	8-752-066-35	IC CXA1563S	
IC308	8-759-634-50	IC M5218AL	
IC309	8-759-634-50	IC M5218AL	
IC310	8-759-000-49	IC MC14066BCP	
IC311	8-759-634-51	IC M5218AP	
IC701	8-759-145-58	IC uPC4558C	
IC801	8-759-254-85	IC uPD78042GF-072-3B9	
IC802	8-759-803-42	IC LA6500-FA	
IC803	8-759-165-82	IC PST600E-T	

Ref. No.	Part No.	Description	Remark
		< JACK >	
J301	1-565-258-11	JACK, PIN 4P (LINE IN/OUT)	
J302	1-568-519-41	JACK, LARGE TYPE (PHONES)	
		< COIL >	
L101	1-410-780-11	INDUCTOR 27mH	
L121	1-410-778-11	INDUCTOR 18mH	
L201	1-410-780-11	INDUCTOR 27mH	
L221	1-410-778-11	INDUCTOR 18mH	
		< FILTER >	
LF701	1-424-485-11	FILTER, LINE	
LPF101	1-235-175-11	FILTER, LOW PASS	
LPF201	1-235-175-11	FILTER, LOW PASS	
		< TRANSISTOR >	
Q101	8-729-900-74	TRANSISTOR DTC143TS	
Q102	8-729-900-80	TRANSISTOR DTC114ES	
Q103	8-729-922-37	TRANSISTOR 2SD2144S	
Q104	8-729-922-37	TRANSISTOR 2SD2144S	
Q105	8-729-900-80	TRANSISTOR DTC114ES	
Q201	8-729-900-74	TRANSISTOR DTC143TS	
Q202	8-729-900-80	TRANSISTOR DTC114ES	
Q203	8-729-922-37	TRANSISTOR 2SD2144S	
Q204	8-729-922-37	TRANSISTOR 2SD2144S	
Q205	8-729-900-80	TRANSISTOR DTC114ES	
Q301	8-729-119-76	TRANSISTOR 2SA1175-HFE	
Q302	8-729-900-80	TRANSISTOR DTC114ES	
Q303	8-729-900-80	TRANSISTOR DTC114ES	
Q304	8-729-900-80	TRANSISTOR DTC114ES	
Q305	8-729-119-76	TRANSISTOR 2SA1175-HFE	
Q306	8-729-900-89	TRANSISTOR DTC144ES	
Q307	8-729-900-80	TRANSISTOR DTC114ES	
Q308	8-729-900-80	TRANSISTOR DTC114ES	
Q309	8-729-900-80	TRANSISTOR DTC114ES	
Q310	8-729-194-57	TRANSISTOR 2SC945-P	
Q311	8-729-194-57	TRANSISTOR 2SC945-P	
Q312	8-729-922-37	TRANSISTOR 2SD2144S	
Q313	8-729-119-78	TRANSISTOR 2SC403SP-51	
Q314	8-729-119-78	TRANSISTOR 2SC403SP-51	
Q315	8-729-900-80	TRANSISTOR DTC114ES	
Q316	8-729-900-74	TRANSISTOR DTC143TS	
Q701	8-729-900-80	TRANSISTOR DTC114ES	
Q702	8-729-900-80	TRANSISTOR DTC114ES	
Q703	8-729-141-83	TRANSISTOR 2SB1094-LK	
Q704	8-729-209-15	TRANSISTOR 2SD2012	
Q705	8-729-209-15	TRANSISTOR 2SD2012	
Q706	8-729-119-78	TRANSISTOR 2SC403SP-51	

MAIN

HEADPHONE

TRANS 1

TRANS 2

Ref. No.	Part No.	Description	Remark
Q707	8-729-900-80	TRANSISTOR DTC114ES	
Q708	8-729-119-76	TRANSISTOR 2SA1175-HFE	
Q709	8-729-140-04	TRANSISTOR 2SB1116A-L	
Q803	8-729-801-84	TRANSISTOR 2SB1013-4	
Q807	8-729-142-36	TRANSISTOR BN1L3Z	
Q808	8-729-422-57	TRANSISTOR UN4111	
Q809	8-729-422-57	TRANSISTOR UN4111	
Q810-814	8-729-900-89	TRANSISTOR DTC144ES	
< RESISTOR >			
R101	1-249-433-11	CARBON 22K 5%	1/4W
R102	1-249-417-11	CARBON 1K 5%	1/4W
R103	1-249-423-11	CARBON 3.3K 5%	1/4W
R104	1-249-428-11	CARBON 8.2K 5%	1/4W
R105	1-249-441-11	CARBON 100K 5%	1/4W
R107	1-249-421-11	CARBON 2.2K 5%	1/4W
R108	1-247-860-11	CARBON 16K 5%	1/4W
R109	1-249-421-11	CARBON 2.2K 5%	1/4W
R110	1-249-417-11	CARBON 1K 5%	1/4W
R112	1-249-423-11	CARBON 3.3K 5%	1/4W
R113	1-249-424-11	CARBON 3.9K 5%	1/4W
R114	1-249-429-11	CARBON 10K 5%	1/4W
R115	1-249-421-11	CARBON 2.2K 5%	1/4W
R116	1-249-425-11	CARBON 4.7K 5%	1/4W
R117	1-249-441-11	CARBON 100K 5%	1/4W
R118	1-249-403-11	CARBON 68 5%	1/4W
R119	1-247-882-11	CARBON 130K 5%	1/4W
R120	1-249-426-11	CARBON 5.6K 5%	1/4W
R121	1-249-421-11	CARBON 2.2K 5%	1/4W
R122	1-249-420-11	CARBON 1.8K 5%	1/4W
R123	1-247-838-00	CARBON 2K 5%	1/4W
R124	1-249-441-11	CARBON 100K 5%	1/4W
R125	1-249-421-11	CARBON 2.2K 5%	1/4W
R126	1-249-425-11	CARBON 4.7K 5%	1/4W
R127	1-249-435-11	CARBON 33K 5%	1/4W
△R128	1-219-153-11	FUSIBLE 10 5%	1/4W F
R129	1-247-883-00	CARBON 150K 5%	1/4W
R130	1-249-434-11	CARBON 27K 5%	1/4W
R131	1-247-874-11	CARBON 62K 5%	1/4W
R133	1-249-410-11	CARBON 270 5%	1/4W
R137	1-249-441-11	CARBON 100K 5%	1/4W
R138	1-249-441-11	CARBON 100K 5%	1/4W
R139	1-247-864-11	CARBON 24K 5%	1/4W
R140	1-249-429-11	CARBON 10K 5%	1/4W
R141	1-249-419-11	CARBON 1.5K 5%	1/4W
R142	1-249-421-11	CARBON 2.2K 5%	1/4W
R143	1-247-844-11	CARBON 3.6K 5%	1/4W
R144	1-249-409-11	CARBON 220 5%	1/4W

Ref. No.	Part No.	Description	Remark
R145	1-249-426-11	CARBON 5.6K 5%	1/4W
R152	1-247-887-00	CARBON 220K 5%	1/4W
R201	1-249-433-11	CARBON 22K 5%	1/4W
R202	1-249-417-11	CARBON 1K 5%	1/4W
R203	1-249-423-11	CARBON 3.3K 5%	1/4W
R204	1-249-428-11	CARBON 8.2K 5%	1/4W
R205	1-249-441-11	CARBON 100K 5%	1/4W
R207	1-249-421-11	CARBON 2.2K 5%	1/4W
R208	1-247-860-11	CARBON 16K 5%	1/4W
R209	1-249-421-11	CARBON 2.2K 5%	1/4W
R210	1-249-417-11	CARBON 1K 5%	1/4W
R212	1-249-423-11	CARBON 3.3K 5%	1/4W
R213	1-249-424-11	CARBON 3.9K 5%	1/4W
R214	1-249-429-11	CARBON 10K 5%	1/4W
R215	1-249-421-11	CARBON 2.2K 5%	1/4W
R216	1-249-425-11	CARBON 4.7K 5%	1/4W
R217	1-249-441-11	CARBON 100K 5%	1/4W
R218	1-249-403-11	CARBON 68 5%	1/4W
R219	1-247-882-11	CARBON 130K 5%	1/4W
R220	1-249-426-11	CARBON 5.6K 5%	1/4W
R221	1-249-421-11	CARBON 2.2K 5%	1/4W
R222	1-249-420-11	CARBON 1.8K 5%	1/4W
R223	1-247-838-00	CARBON 2K 5%	1/4W
R224	1-249-441-11	CARBON 100K 5%	1/4W
R225	1-249-421-11	CARBON 2.2K 5%	1/4W
R226	1-249-425-11	CARBON 4.7K 5%	1/4W
R227	1-249-435-11	CARBON 33K 5%	1/4W
△R228	1-219-153-11	FUSIBLE 10 5%	1/4W F
R229	1-247-883-00	CARBON 150K 5%	1/4W
R230	1-249-434-11	CARBON 27K 5%	1/4W
R231	1-247-874-11	CARBON 62K 5%	1/4W
R233	1-249-410-11	CARBON 270 5%	1/4W
R237	1-249-441-11	CARBON 100K 5%	1/4W
R238	1-249-441-11	CARBON 100K 5%	1/4W
R239	1-247-864-11	CARBON 24K 5%	1/4W
R240	1-249-429-11	CARBON 10K 5%	1/4W
R241	1-249-419-11	CARBON 1.5K 5%	1/4W
R242	1-249-421-11	CARBON 2.2K 5%	1/4W
R243	1-247-844-11	CARBON 3.6K 5%	1/4W
R244	1-249-409-11	CARBON 220 5%	1/4W
R245	1-249-426-11	CARBON 5.6K 5%	1/4W
R252	1-247-887-00	CARBON 220K 5%	1/4W
R302	1-247-848-11	CARBON 5.1K 5%	1/4W
R303	1-249-421-11	CARBON 2.2K 5%	1/4W
R304	1-249-421-11	CARBON 2.2K 5%	1/4W
R305	1-215-452-00	METAL 20K 1%	1/4W
R306	1-249-436-11	CARBON 39K 5%	1/4W
R307	1-249-433-11	CARBON 22K 5%	1/4W
R308	1-249-441-11	CARBON 100K 5%	1/4W

The components identified by mark △ or dotted line with mark △ are critical for safety. Replace only with part number specified.

MAIN



HEADPHONE

TRANS 1

TRANS 2

Ref. No.	Part No.	Description	Remark
R309	1-247-864-11	CARBON	24K 5% 1/4W
R310	1-249-441-11	CARBON	100K 5% 1/4W
R311	1-249-441-11	CARBON	100K 5% 1/4W
R312	1-249-433-11	CARBON	22K 5% 1/4W
R313	1-247-878-00	CARBON	91K 5% 1/4W
R314	1-249-439-11	CARBON	68K 5% 1/4W
R315	1-247-870-11	CARBON	43K 5% 1/4W
R316	1-249-435-11	CARBON	33K 5% 1/4W
R317	1-247-876-11	CARBON	75K 5% 1/4W
R318	1-247-887-00	CARBON	220K 5% 1/4W
R319	1-247-878-00	CARBON	91K 5% 1/4W
R320	1-247-874-11	CARBON	62K 5% 1/4W
R321	1-247-878-00	CARBON	91K 5% 1/4W
R322	1-249-437-11	CARBON	47K 5% 1/4W
R323	1-249-439-11	CARBON	68K 5% 1/4W
R324	1-247-886-11	CARBON	200K 5% 1/4W
R325	1-247-874-11	CARBON	62K 5% 1/4W
R326	1-247-874-11	CARBON	62K 5% 1/4W
R327	1-249-435-11	CARBON	33K 5% 1/4W
R328	1-249-438-11	CARBON	56K 5% 1/4W
R329	1-249-440-11	CARBON	82K 5% 1/4W
R330	1-247-836-11	CARBON	1. 6K 5% 1/4W
R331	1-249-429-11	CARBON	10K 5% 1/4W
R332	1-249-422-11	CARBON	2. 7K 5% 1/4W
R333	1-249-417-11	CARBON	1K 5% 1/4W
R334	1-249-417-11	CARBON	1K 5% 1/4W
R335	1-247-822-11	CARBON	430 5% 1/4W
R336	1-249-417-11	CARBON	1K 5% 1/4W
R337	1-249-429-11	CARBON	10K 5% 1/4W
R338	1-249-421-11	CARBON	2. 2K 5% 1/4W
R339	1-249-440-11	CARBON	82K 5% 1/4W
R340	1-249-440-11	CARBON	82K 5% 1/4W
R341	1-249-390-11	CARBON	5. 6 5% 1/4W
R342	1-249-390-11	CARBON	5. 6 5% 1/4W
R343	1-249-437-11	CARBON	47K 5% 1/4W
R344	1-249-429-11	CARBON	10K 5% 1/4W
R345	1-249-441-11	CARBON	100K 5% 1/4W
R346	1-249-441-11	CARBON	100K 5% 1/4W
R347	1-249-429-11	CARBON	10K 5% 1/4W
R348	1-249-428-11	CARBON	8. 2K 5% 1/4W
R349	1-249-441-11	CARBON	100K 5% 1/4W
R350	1-249-441-11	CARBON	100K 5% 1/4W
R351	1-249-423-11	CARBON	3. 3K 5% 1/4W
R352	1-249-429-11	CARBON	10K 5% 1/4W
R353	1-249-429-11	CARBON	10K 5% 1/4W
R354	1-249-417-11	CARBON	1K 5% 1/4W
R355	1-249-430-11	CARBON	12K 5% 1/4W
R356	1-249-435-11	CARBON	33K 5% 1/4W
R357	1-247-848-11	CARBON	5. 1K 5% 1/4W

Ref. No.	Part No.	Description	Remark
R358	1-249-437-11	CARBON	47K 5% 1/4W
R359	1-249-434-11	CARBON	27K 5% 1/4W
R360	1-249-437-11	CARBON	47K 5% 1/4W
R361	1-249-429-11	CARBON	10K 5% 1/4W
R363	1-215-452-00	METAL	20K 1% 1/4W
R365	1-249-433-11	CARBON	22K 5% 1/4W
R366	1-247-862-11	CARBON	20K 5% 1/4W
R367	1-249-429-11	CARBON	10K 5% 1/4W
R368	1-249-429-11	CARBON	10K 5% 1/4W
R701	1-249-433-11	CARBON	22K 5% 1/4W
R702	1-249-425-11	CARBON	4. 7K 5% 1/4W
R703	1-249-420-11	CARBON	1. 8K 5% 1/4W
R704	1-249-421-11	CARBON	2. 2K 5% 1/4W
R705	1-249-427-11	CARBON	6. 8K 5% 1/4W
R706	1-249-419-11	CARBON	1. 5K 5% 1/4W
R707	1-249-429-11	CARBON	10K 5% 1/4W
R708	1-249-419-11	CARBON	1. 5K 5% 1/4W
R709	1-249-425-11	CARBON	4. 7K 5% 1/4W
R711	1-249-417-11	CARBON	1K 5% 1/4W
R712	1-249-427-11	CARBON	6. 8K 5% 1/4W
R713	1-249-427-11	CARBON	6. 8K 5% 1/4W
R714	1-249-419-11	CARBON	1. 5K 5% 1/4W
R715	1-249-425-11	CARBON	4. 7K 5% 1/4W
R716	1-249-429-11	CARBON	10K 5% 1/4W
R718	1-249-433-11	CARBON	22K 5% 1/4W
R719	1-249-429-11	CARBON	10K 5% 1/4W
R720	1-249-423-11	CARBON	3. 3K 5% 1/4W
R721	1-249-437-11	CARBON	47K 5% 1/4W
△R730	1-219-137-11	FUSIBLE	0. 33 10% 1/4W F
△R731	1-219-136-11	FUSIBLE	0. 22 10% 1/4W F
R801	1-249-435-11	CARBON	33K 5% 1/4W
R802	1-249-429-11	CARBON	10K 5% 1/4W
R803	1-247-862-11	CARBON	20K 5% 1/4W
R805	1-249-417-11	CARBON	1K 5% 1/4W
R806	1-249-417-11	CARBON	1K 5% 1/4W
R807	1-249-430-11	CARBON	12K 5% 1/4W
R808	1-249-433-11	CARBON	22K 5% 1/4W
R809	1-249-433-11	CARBON	22K 5% 1/4W
R811	1-249-425-11	CARBON	4. 7K 5% 1/4W
R812	1-249-425-11	CARBON	4. 7K 5% 1/4W
R813	1-247-866-11	CARBON	30K 5% 1/4W
R814	1-247-866-11	CARBON	30K 5% 1/4W
R815	1-249-437-11	CARBON	47K 5% 1/4W
R817	1-249-441-11	CARBON	100K 5% 1/4W
R818	1-249-417-11	CARBON	1K 5% 1/4W
R821	1-249-433-11	CARBON	22K 5% 1/4W
R822	1-249-393-11	CARBON	10 5% 1/4W
R823	1-249-437-11	CARBON	47K 5% 1/4W
R824	1-249-437-11	CARBON	47K 5% 1/4W

The components identified by mark  or dotted line with mark  are critical for safety. Replace only with part number specified.

MAIN
HEADPHONE
TRANS 1
TRANS 2
PANEL
FL
VOL

Ref. No.	Part No.	Description	Remark
R825	1-249-429-11	CARBON 10K 5%	1/4W
R826	1-249-429-11	CARBON 10K 5%	1/4W
R827	1-247-807-31	CARBON 100 5%	1/4W
R828	1-249-429-11	CARBON 10K 5%	1/4W
R829	1-249-429-11	CARBON 10K 5%	1/4W
R830	1-249-429-11	CARBON 10K 5%	1/4W
< VARIABLE RESISTOR >			
RV101	1-241-765-11	RES, ADJ, CARBON 22K (REC LEVEL)	
RV102	1-238-019-11	RES, ADJ, CARBON 47K (REC EQ (IV))	
RV103	1-241-765-11	RES, ADJ, CARBON 22K (REC BIAS)	
RV121	1-241-763-11	RES, ADJ, CARBON 4.7K (PB LEVEL)	
RV201	1-241-765-11	RES, ADJ, CARBON 22K (REC LEVEL)	
RV202	1-238-019-11	RES, ADJ, CARBON 47K (REC EQ (IV))	
RV203	1-241-765-11	RES, ADJ, CARBON 22K (REC BIAS)	
RV221	1-241-763-11	RES, ADJ, CARBON 4.7K (PB LEVEL)	
RV306	1-223-387-21	RES, ADJ, CARBON 330K (REC EQ (IV))	
< TRANSFORMER >			
T101	1-433-344-11	TRANSFORMER, BIAS OSCILLATION	
T201	1-433-344-11	TRANSFORMER, BIAS OSCILLATION	
T301	1-423-614-11	TRANSFORMER, BIAS OSCILLATION	
< TEST PIN >			
* TP301	1-564-506-11	PLUG, CONNECTOR 3P	
* TP801	1-560-060-00	PIN, CONNECTOR 2P	
< VIBRATOR >			
X801	1-577-358-21	VIBRATOR, CERAMIC (4MHz)	

* A-2007-361-A	PANEL BOARD, COMPLETE		

	FL BOARD		

	VOL BOARD		

< CONNECTOR >			
CNP903	1-770-246-11	SOCKET, CONNECTOR 41P	
* CNP906	1-568-824-11	SOCKET, CONNECTOR 5P	
* CNP907	1-568-824-11	SOCKET, CONNECTOR 5P	
< DIODE >			
D901	8-719-987-63	DIODE 1N4148M	
D902	8-719-987-63	DIODE 1N4148M	
D903	8-719-987-63	DIODE 1N4148M	

Ref. No.	Part No.	Description	Remark
< IC >			
IC901	8-741-810-59	IC SBX1810-59	
< RESISTOR >			
R153	1-249-425-11	CARBON 4.7K 5%	1/4W
R253	1-249-425-11	CARBON 4.7K 5%	1/4W
R362	1-249-429-11	CARBON 10K 5%	1/4W
R901	1-247-838-00	CARBON 2K 5%	1/4W
R902	1-249-422-11	CARBON 2.7K 5%	1/4W
R903	1-247-848-11	CARBON 5.1K 5%	1/4W
R904	1-249-430-11	CARBON 12K 5%	1/4W
R905	1-247-866-11	CARBON 30K 5%	1/4W
R906	1-249-422-11	CARBON 2.7K 5%	1/4W
R907	1-249-424-11	CARBON 3.9K 5%	1/4W
R908	1-249-428-11	CARBON 8.2K 5%	1/4W
R909	1-249-434-11	CARBON 27K 5%	1/4W
R910	1-247-838-00	CARBON 2K 5%	1/4W
R911	1-249-422-11	CARBON 2.7K 5%	1/4W
R912	1-247-848-11	CARBON 5.1K 5%	1/4W
R913	1-249-430-11	CARBON 12K 5%	1/4W
R914	1-247-866-11	CARBON 30K 5%	1/4W
R915	1-249-441-11	CARBON 100K 5%	1/4W
< VARIABLE RESISTOR >			
RV301	1-241-820-11	RES, VAR, CARBON 50K/50K (REC LEVEL)	
RV302	1-241-897-11	RES, VAR, CARBON 50K/50K (BALANCE)	
RV303	1-241-896-11	RES, VAR, CARBON 10K (BIAS)	
RV304	1-223-366-11	RES, VAR, CARBON 5K/5K (REC LEVEL)	
< SWITCH >			
S901	1-554-303-21	SWITCH, TACTILE (▷)	
S902	1-554-303-21	SWITCH, TACTILE (▨)	
S903	1-554-303-21	SWITCH, TACTILE (RESET)	
S904	1-554-303-21	SWITCH, TACTILE (MEMORY)	
S905	1-554-303-21	SWITCH, TACTILE (MONITOR)	
S906	1-554-303-21	SWITCH, TACTILE (■)	
S907	1-554-303-21	SWITCH, TACTILE (◀◀)	
S908	1-554-303-21	SWITCH, TACTILE (▶▶)	
S909	1-554-303-21	SWITCH, TACTILE (●)	
S910	1-554-303-21	SWITCH, TACTILE (○)	
S911	1-554-303-21	SWITCH, TACTILE (CALIBRATION)	
S921	1-692-409-11	SWITCH, PUSH (1 KEY) (POWER)	
S922	1-554-118-00	SWITCH, PUSH (1 KEY) (MPX FILTER)	
S923	1-692-410-11	SWITCH, ROTARY (DOLBY NR)	

SW-A

Ref. No.	Part No.	Description	Remark
*	1-634-841-14	SW-A BOARD ***** < CONNECTOR >	
* CNP81	1-568-852-11	SOCKET, CONNECTOR 9P < IC >	
IC81	8-749-924-10	IC NJL5165K-B(H1)	
IC82	8-749-924-10	IC NJL5165K-B(H1) < RESISTOR >	
R81	1-249-414-11	CARBON 560 5% 1/4W	
R83	1-247-834-11	CARBON 1.3K 5% 1/4W	
R84	1-249-417-11	CARBON 1K 5% 1/4W	
R85	1-249-408-11	CARBON 180 5% 1/4W	
R86	1-249-408-11	CARBON 180 5% 1/4W < SWITCH >	
S81	1-571-958-11	SWITCH, PUSH (1 KEY) (STOP)	
S82	1-571-281-21	SWITCH, LEAF (70u)	
S83	1-571-281-21	SWITCH, LEAF (METAL)	
S84	1-571-281-21	SWITCH, LEAF (REC)	
S86	1-571-281-21	SWITCH, LEAF (HALF)	

MISCELLANEOUS *****			
△14	1-558-945-21	CORD, POWER (POLAR. SPT-1) (US)	
△14	1-575-651-21	CORD, POWER (AEP, G)	
△14	1-696-027-11	CORD, POWER (E)	
△14	1-696-586-11	CORD, POWER (UK)	
△14	1-696-845-11	CORD, POWER (AUS)	
△16	1-569-007-11	ADAPTER, CONVERSION 2P (E)	
66	1-769-406-11	WIRE (FLAT TYPE) (41 CORE)	
70	1-751-732-11	WIRE (FLAT TYPE) (9 CORE)	
71	1-751-733-11	WIRE (FLAT TYPE) (7 CORE)	
76	1-769-431-11	WIRE (FLAT TYPE) (5 CORE)	
78	1-751-734-11	WIRE (FLAT TYPE) (5 CORE)	
120	1-638-983-11	PC BOARD, MOTOR FLEXIBLE	
△F701	1-532-285-00	FUSE, TIME-LAG (TC-K561S)	
△F701	1-532-741-11	FUSE, GLASS TUBE (TC-KA1ES)	
△F702	1-532-285-00	FUSE, TIME-LAG (TC-K561S)	
△F702	1-532-741-11	FUSE, GLASS TUBE (TC-KA1ES)	
HE101	1-543-673-11	HEAD, MAGNETIC (ERASE)	
HRP101	1-543-733-11	HEAD, MAGNETIC (RECORD/PLAYBACK)	
M1	X-3363-501-2	MOTOR ASSY (REEL)	
M2	X-3368-855-1	MOTOR ASSY (CAPSTAN)	
△S701	1-692-155-11	SELECTOR, POWER VOLTAGE (VOLTAGE) (E)	
△T701	1-426-726-21	TRANSFORMER, POWER (US)	

Ref. No.	Part No.	Description	Remark
△T701	1-426-727-21	TRANSFORMER, POWER (AEP, UK, G, AUS)	
△T701	1-426-728-21	TRANSFORMER, POWER (E)	
VFD901	1-517-163-11	INDICATOR TUBE, FLUORESCENT	

ACCESSORIES & PACKING MATERIALS *****			
	1-551-734-11	CORD, CONNECTION	
	3-798-436-11	MANUAL, INSTRUCTION (AEP) (ENGLISH/FRENCH/SPANISH/PORTUGUESE)	
	3-798-436-21	MANUAL, INSTRUCTION (UK, AUS, US) (ENGLISH)	
	3-798-436-41	MANUAL, INSTRUCTION (AEP) (GERMAN/DUTCH/SWEDISH/ITALIAN)	
	3-798-436-51	MANUAL, INSTRUCTION (G) (GERMAN)	
	3-798-436-61	MANUAL, INSTRUCTION (E) (ENGLISH/FRENCH/SPANISH/CHINESE)	
*	3-907-887-01	CUSHION	
*	3-923-964-01	INDIVIDUAL CARTON (E, AUS)	
*	3-923-964-11	INDIVIDUAL CARTON (AEP, UK, G)	
*	3-923-964-21	INDIVIDUAL CARTON (US)	

HARDWARE LIST

#1	7-682-548-09	SCREW +BVT 3×8 (S)
#2	7-682-548-04	SCREW +BVT 3×8 (S)
#3	7-621-773-95	SCREW +BVT 2.6×6 (S)
#4	7-685-134-19	SCREW +PTPWH (2.6×8)
#5	7-685-534-19	SCREW +BTP 2.6×8 TYPE2 N-S (E)
#6	7-621-772-10	SCREW +B 2×4
#7	7-627-556-08	SCREW +P 2.6×2.8
#8	7-621-775-00	SCREW +B 2.6×3

The components identified by mark △ or dotted line with mark △ are critical for safety. Replace only with part number specified.