

# TC-KA3ES

## SERVICE MANUAL

US Model  
Canadian Model  
E Model

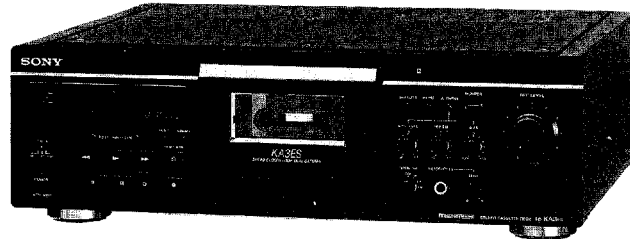

Model Name Using Similar Mechanism	TC-K222ESJ
Tape Transport Mechanism Type	TCM-200D15

### SPECIFICATIONS

#### System

Recording system  
4-track 2-channel stereo

Fast winding time (approx.)  
90 sec. (with Sony C-60 cassette)

Bias  
AC bias

#### Heads

Erasing	S&F
Recording	LA
Playing	LA

#### Motors

Capstan motor x 1 (direct drive linear torque BSL motor)  
Reel motor x 1 (DC motor)  
Assist (mechanism drive) motor x 1 (DC motor)

Signal-to-noise ratio (at peak level, weighted, and with Dolby NR off)  
Type I tape, Sony Type I (NORMAL): 57 dB  
Type II tape, Sony Type II (HIGH): 59 dB  
Type IV tape, Sony Type IV (METAL): 61 dB

#### S/N ratio improvement

Dolby NR on	Approximate values
B	5 dB at 1 kHz, 10 dB at 5 kHz
C	15 dB at 500 Hz, 20 dB at 1 kHz
S	10 dB at 100 Hz, 24 dB at 1 kHz

#### Harmonic distortion

Tape type	
Type I tape	0.4% (160 nWb/m)
Sony Type I (NORMAL)	315 Hz, 3rd H.D.)
Type IV tape	1.3% (250 nWb/m)
Sony Type IV (METAL)	315 Hz, 3rd H.D.)

#### Frequency response (Dolby NR off)

Tape type	
Type I tape	15 - 17,000 Hz
Sony Type I (NORMAL)	(±3 dB, IEC)
Type II tape	15 - 20,000 Hz
Sony Type II (HIGH)	(±3 dB, IEC)
Type IV tape	15 - 22,000 Hz
Sony Type IV (METAL)	(±3 dB, IEC)
	15 - 16,000 Hz
	(±3 dB, -4dB recording)

#### Wow and flutter

±0.04% W. Peak (IEC)
0.022% W. RMS (NAB)
±0.065% W. Peak (DIN)

#### Inputs

Line inputs (phono jacks)  
Sensitivity: 0.16 V  
Input impedance: 47 kilohms

#### Outputs

Line outputs (phono jacks)  
Rated output level: 0.5 V at a load impedance of 47 kilohms  
Load impedance: Over 10 kilohms

#### Headphones (stereo phone jack)

Output level: 0 - 3 mW at a load impedance of 32 ohms

#### General

##### Power requirements

Where purchased	Power requirements
U.S.A. and Canada	120 V AC, 60 Hz
Other countries	120, 220 or 240 V AC adjustable, 50/60 Hz

##### Power consumption

30 W

##### Dimensions (approx.) (w/h/d)

430 x 135 x 360 mm (17 x 5 1/4 x 14 1/4 inches)  
incl. projecting parts and controls

##### Mass (approx.)

7.6 kg (16 lbs 13 oz)

##### Supplied accessories

Audio connecting cords (2)  
Remote commander RM-J701 (1)\*  
Sony batteries SUM-3(NS) (2)\*

\* Canadian model only

Design and specifications are subject to change without notice.

STEREO CASSETTE DECK  
**SONY**®

## TABLE OF CONTENTS

<u>Section</u>	<u>Title</u>	<u>Page</u>
SECTION 1. GENERAL .....		3
SECTION 2. DISASSEMBLY		
2-1. Mechanism Deck .....		4
2-2. Cassette Holder .....		4
2-3. Ornamental Plate .....		5
2-4. Pinch Lever and Lever (FR) .....		5
2-5. Comparator Board, Capstan Board and FG Board.....		6
2-6. MD Board .....		6
2-7. Reel Motor Board .....		7
SECTION 3. MECHANICAL ADJUSTMENTS.....		7
SECTION 4. ELECTRICAL ADJUSTMENTS .....		10
SECTION 5. DIAGRAMS		
5-1. IC Pin Functions		
• IC801 M38172M4-133FP .....		15
• IC851 M38122M2-069SP .....		17
5-2. Circuit Boards Location .....		18
5-3. Block Diagram .....		19
5-4. Printed Wiring Board — Audio Section — .....		23
5-5. Schematic Diagram — Audio Section — .....		27
5-6. Printed Wiring Board — System Control Section — .....		31
5-7. Schematic Diagram		
— System Control (1/2) Section — .....		35
5-8. Schematic Diagram		
— System Control (2/2) Section — .....		39
5-9. IC Block Diagrams .....		42
SECTION 6. EXPLODED VIEWS		
6-1. Front Panel Section .....		44
6-2. Chassis Section .....		45
6-3. Mechanism Section 1 (TCM-200D15) .....		46
6-4. Mechanism Section 2 (TCM-200D15) .....		47
SECTION 7. ELECTRICAL PARTS LIST .....		48

\* Dolby noise reduction and HX Pro headroom extension manufactured under license from Dolby Laboratories Licensing Corporation. HX Pro originated by Bang & Olufsen. "DOLBY," the double-D symbol  and "HX PRO" are trademarks of Dolby Laboratories Licensing Corporation.

### Notes on chip component replacement

- Never reuse a disconnected chip component.
- Notice that the minus side of a tantalum capacitor may be damaged by heat.

## SAFETY CHECK-OUT

After correcting the original service problem, perform the following safety checks before releasing the set to the customer:

Check the antenna terminals, metal trim, "metallized" knobs, screws, and all other exposed metal parts for AC leakage. Check leakage as described below.

### LEAKAGE

The AC leakage from any exposed metal part to earth ground and from all exposed metal parts to any exposed metal part having a return to chassis, must not exceed 0.5 mA (500 microampers). Leakage current can be measured by any one of three methods.

1. A commercial leakage tester, such as the Simpson 229 or RCA WT-540A. Follow the manufacturers' instructions to use these instruments.
2. A battery-operated AC milliammeter. The Data Precision 245 digital multimeter is suitable for this job.
3. Measuring the voltage drop across a resistor by means of a VOM or battery-operated AC voltmeter. The "limit" indication is 0.75 V, so analog meters must have an accurate low-voltage scale. The Simpson 250 and Sanwa SH-63Trd are examples of a passive VOM that is suitable. Nearly all battery operated digital multimeters that have a 2V AC range are suitable. (See Fig. A)

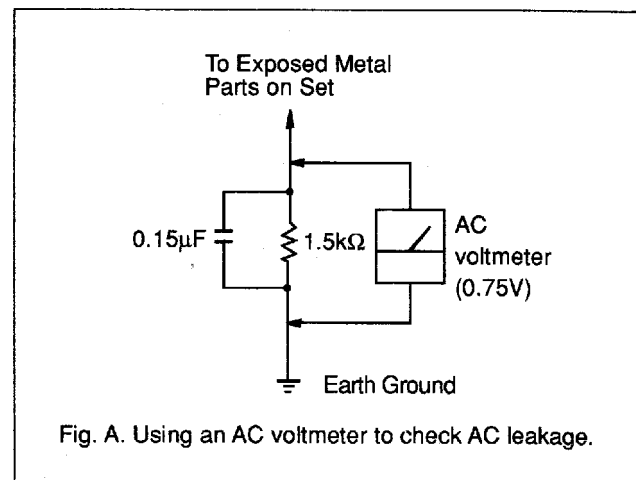

Fig. A. Using an AC voltmeter to check AC leakage.

### SAFETY-RELATED COMPONENT WARNING !!

**COMPONENTS IDENTIFIED BY MARK  $\Delta$  OR DOTTED LINE WITH MARK  $\Delta$  ON THE SCHEMATIC DIAGRAMS AND IN THE PARTS LIST ARE CRITICAL TO SAFE OPERATION. REPLACE THESE COMPONENTS WITH SONY PARTS WHOSE PART NUMBERS APPEAR AS SHOWN IN THIS MANUAL OR IN SUPPLEMENTS PUBLISHED BY SONY.**

### ATTENTION AU COMPOSANT AYANT RAPPORT À LA SÉCURITÉ!!

**LES COMPOSANTS IDENTIFIÉS PAR UNE MARQUE  $\Delta$  SUR LES DIAGRAMMES SCHÉMATIQUES ET LA LISTE DES PIÈCES SONT CRITIQUES POUR LA SÉCURITÉ DE FONCTIONNEMENT. NE REMPLACER CES COMPOSANTS QUE PAR DES PIÈCES SONY DONT LES NUMÉROS SONT DONNÉS DANS CE MANUEL OU DANS LES SUPPLÉMENTS PUBLIÉS PAR SONY.**

## SECTION 1 GENERAL

### Identifying the Parts

#### FRONT PANEL

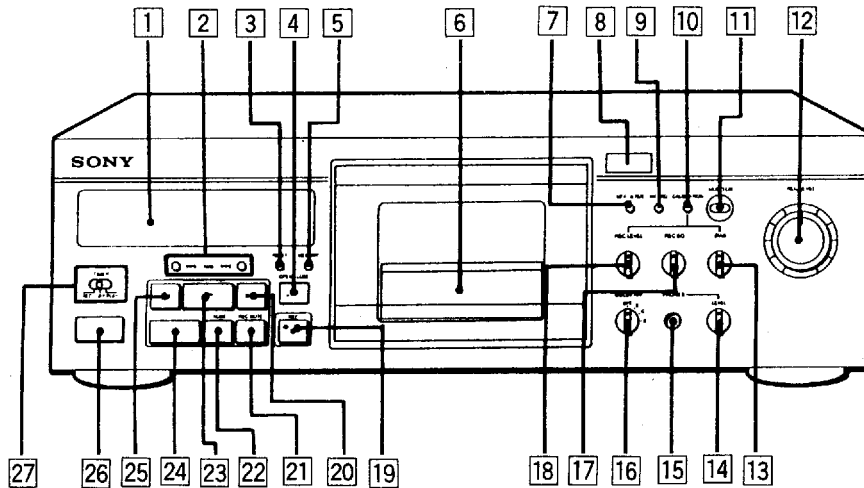

- |  |  |
|--|--|
| <ul style="list-style-type: none"> <li>1 Level meter and Tape counter</li> <li>2 ◀◀/▶▶ (AMS)* buttons</li> <li>3 RESET button</li> <li>4 △ OPEN/CLOSE button</li> <li>5 MEMORY button</li> <li>6 Cassette holder</li> <li>7 MPX (multiplex) FILTER button</li> <li>8 Remote control sensor (canadian only)</li> <li>9 HX PRO button</li> <li>10 CALIBRATION button</li> <li>11 MONITOR button</li> <li>12 REC (recording) LEVEL control</li> <li>13 BIAS control</li> <li>14 PHONES LEVEL control</li> </ul> | <ul style="list-style-type: none"> <li>15 PHONES jack</li> <li>16 DOLBY NR (noise reduction) switch</li> <li>17 REC (recording) EQ (equalizer) control</li> <li>18 REC (recording) LEVEL (for calibration) control</li> <li>19 ● REC (recording) button</li> <li>20 ►► (fast-forward) button</li> <li>21 ○ REC MUTE (record muting) button</li> <li>22    PAUSE button</li> <li>23 ► (play) button</li> <li>24 ■ (stop) button</li> <li>25 ◀◀ (rewind) button</li> <li>26 POWER switch</li> <li>27 TIMER switch</li> </ul> |
|--|--|

\* AMS is the abbreviation of Automatic Music Sensor.

## SECTION 2 DISASSEMBLY

**Note :** Follow the disassembly procedure in the numerical order given.

### 2-1. MECHANISM DECK

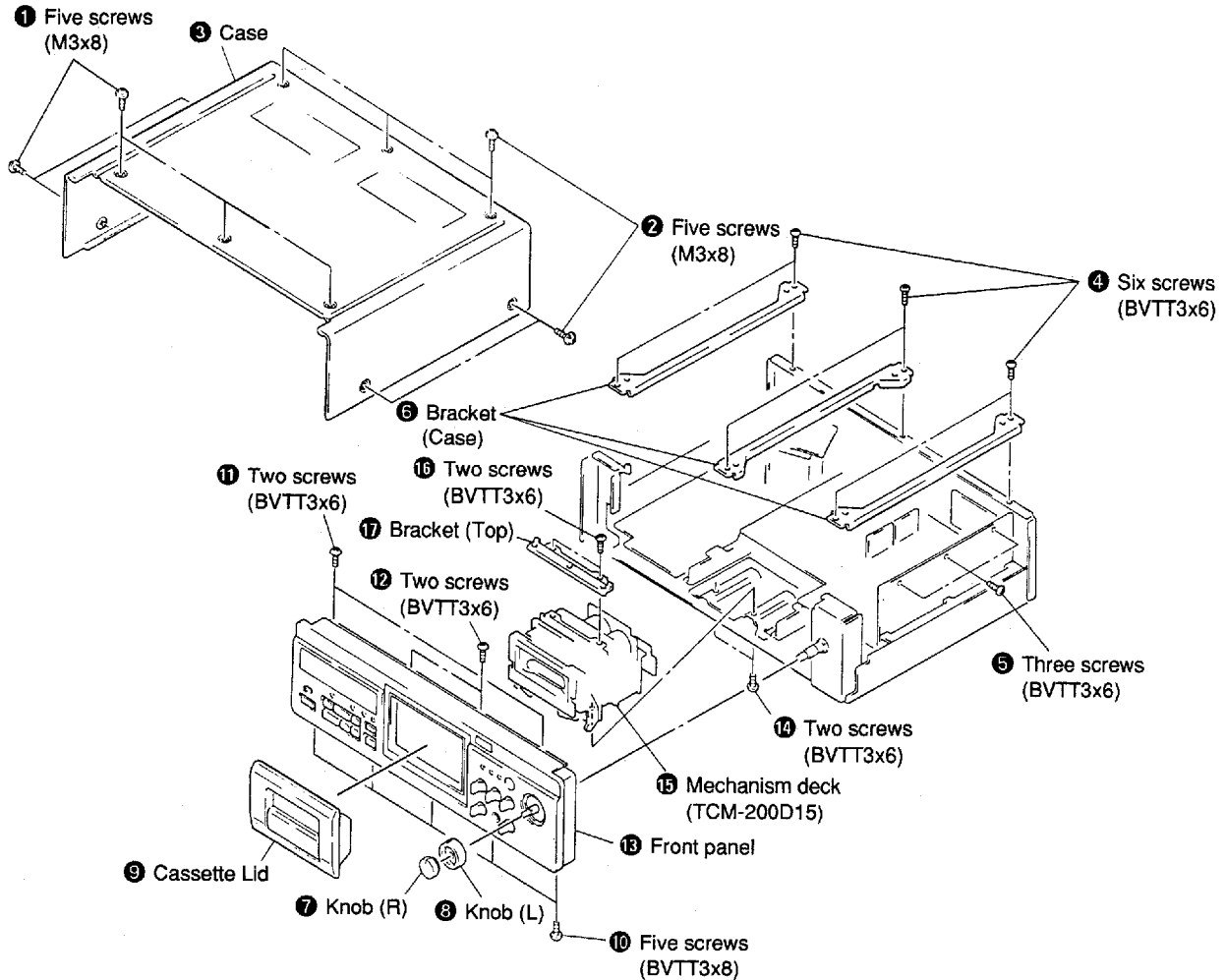

### 2-2. CASSETTE HOLDER

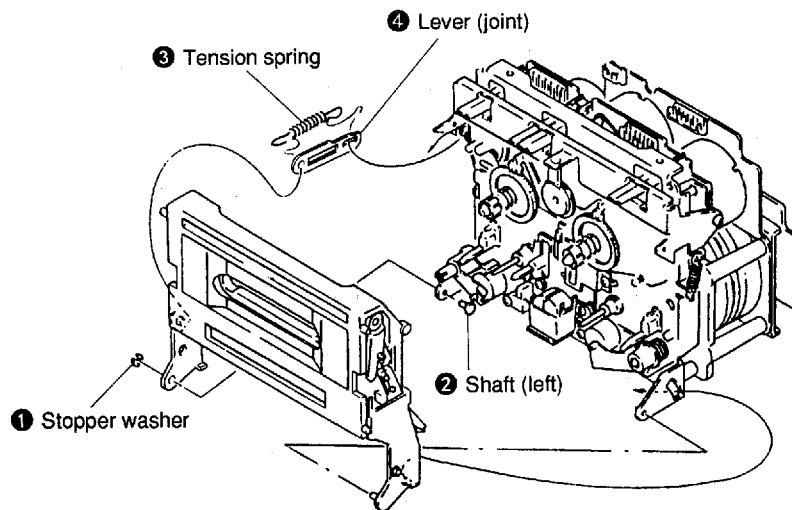

### 2-3. ORNAMENTAL PLATE

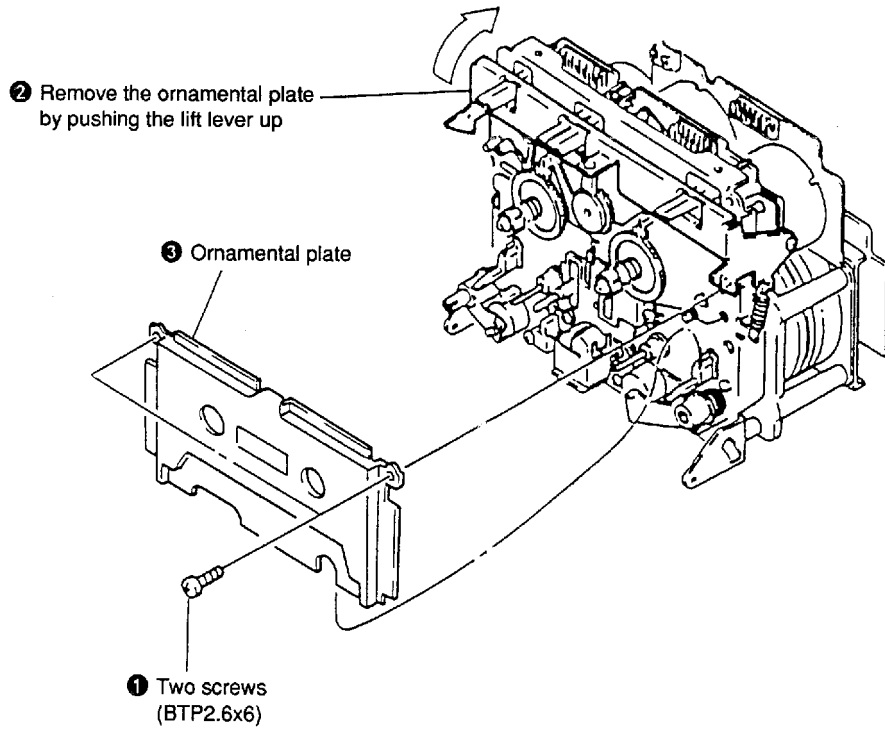

### 2-4. PINCH LEVER AND LEVER (FR)

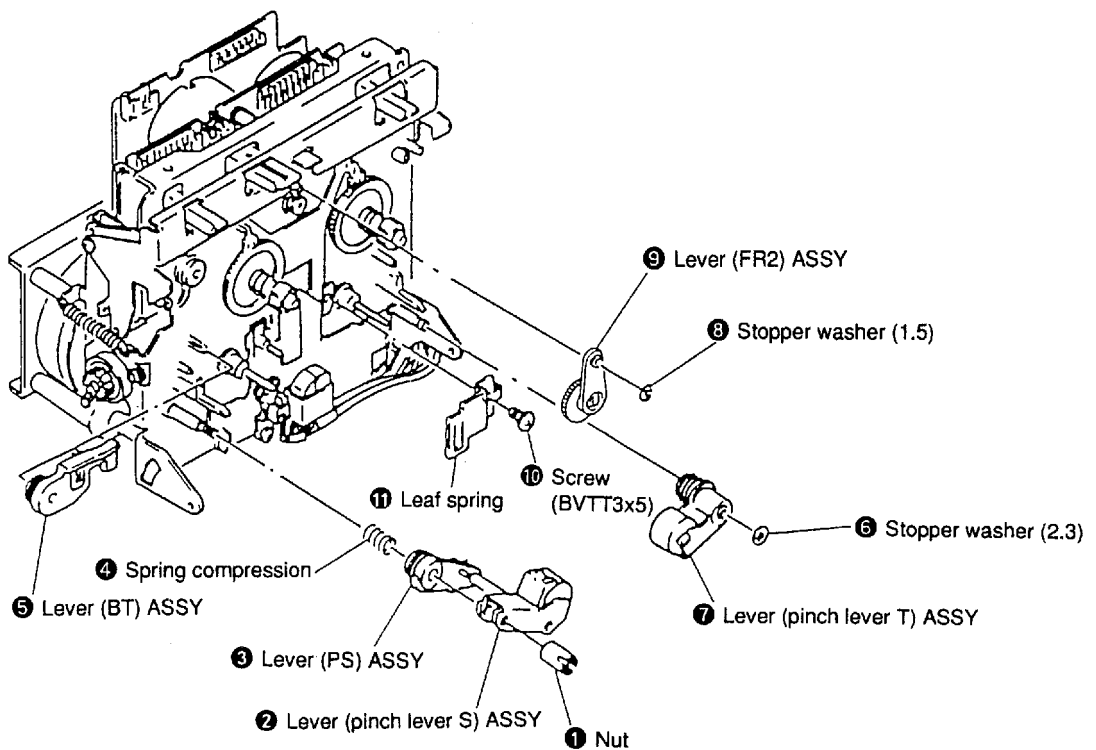

## 2-5. COMPARATOR BOARD, CAPSTAN BOARD AND FG BOARD

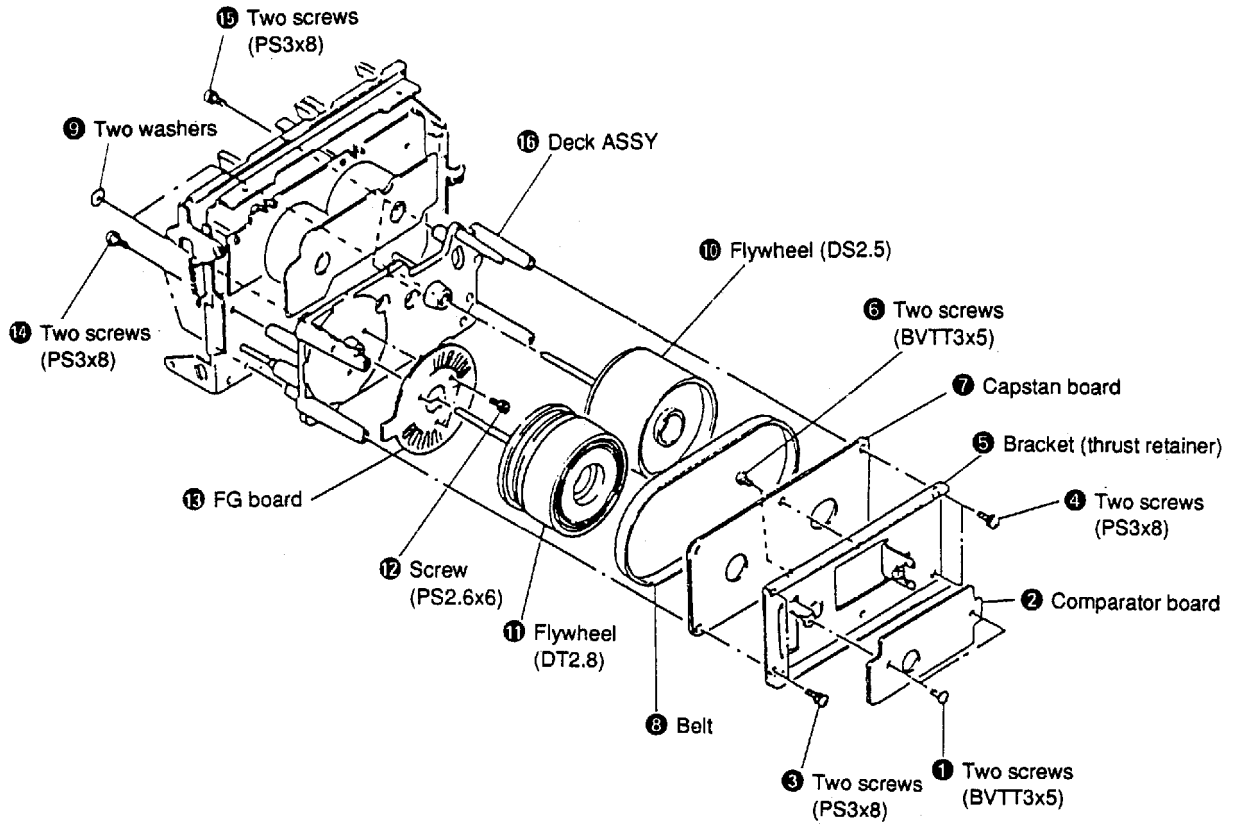

## 2-6. MD BOARD

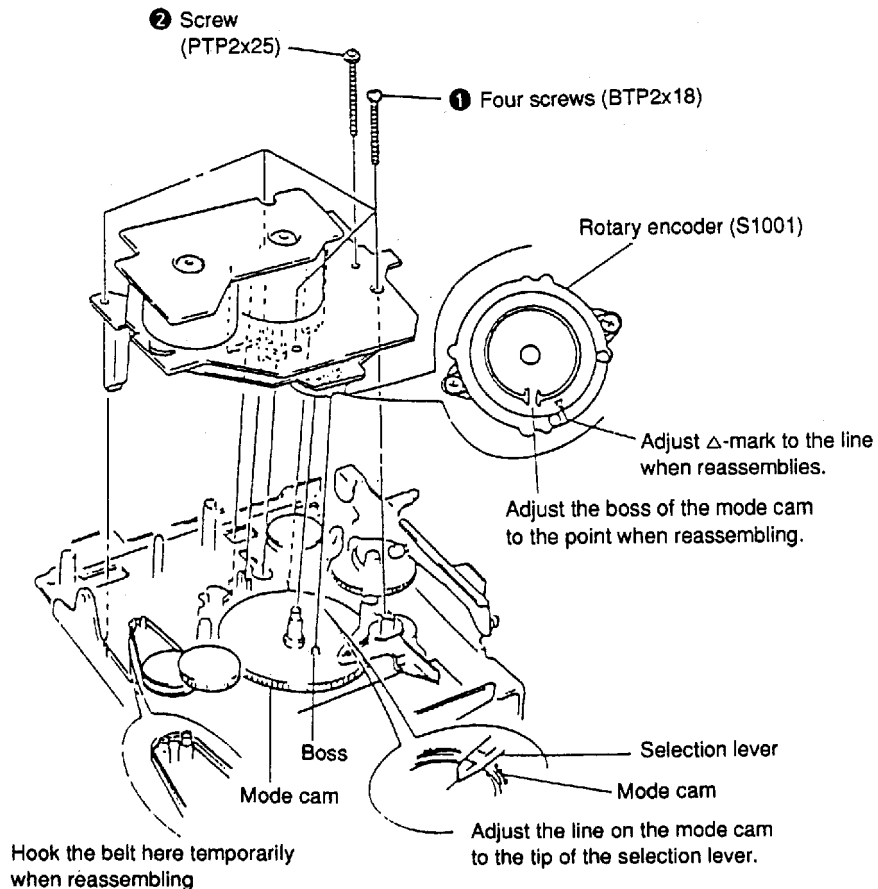

## 2-7. REEL MOTOR BOARD

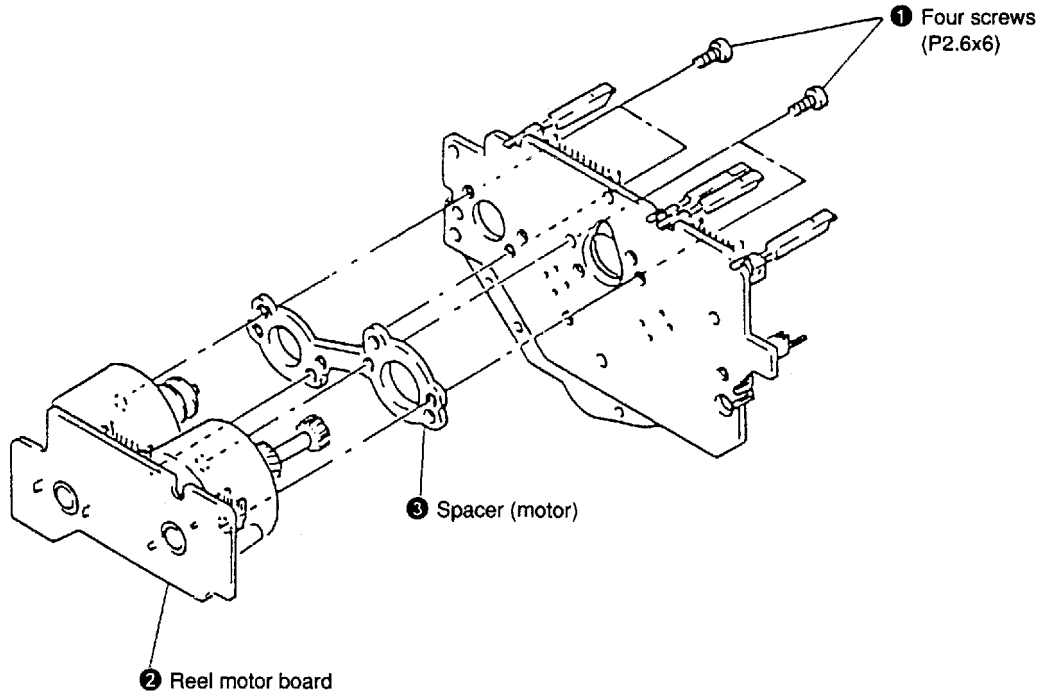

## SECTION 3 MECHANICAL ADJUSTMENTS

• Refer to page 9 for Adjustment Location.

### PRECAUTIONS

1. Clean the following parts with an alcohol-moistened swab.  
(tape sliding surface)
2. Demagnetize the record/playback heads, erase heads and the capstan using the head demagnetizer.
3. Do not use a magnetized screw driver for the adjustments.
4. After the adjustments, apply suitable locking compound to the parts adjusted.
5. The adjustment should be performed with the rated power supply voltage unless otherwise noted.

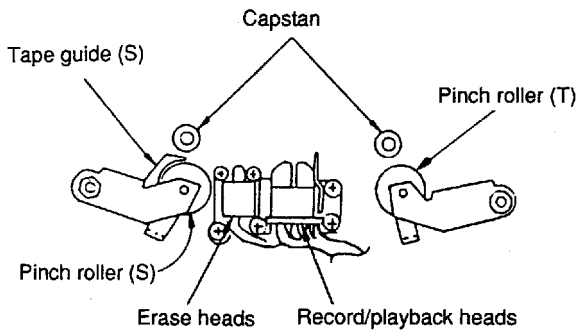

## Tape Passing Adjustment

**Note:** For the following adjustments, use the jig as far as possible. Although the following methods are operable without using the jig, precise adjustment may not be completed, for example no compatibility to other decks is available even if self recording and playback is OK. In these adjustments, either the pinch roller guide in the S side or the record/playback head guide is referred to for tape pass. Therefore, do not unnecessarily rotate the adjustment screws including those of the erase heads unless any one is replaced. When 2 or more heads or pinch rollers out of these 2 heads and pinch rollers are to be adjusted or replaced, use the jig for the adjustments or replace one at first and then take complete tape pass and then replace the second one.

Head height adjusting jig: apex

### Preparation:

- Mirror cassette CQ009C 8-909-708-01  
(Or CQ012C 8-909-708-02)

If it is not available, cut a part of the half of a 120 minute cassette tape and use.

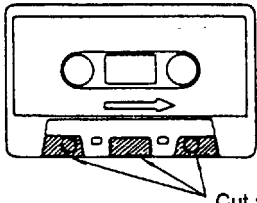

- Plus screw driver  
Medium size ..... Apply to the head adjusting screw.  
Minus screw driver  
Large size..... Apply to the pinch roller adjusting screw in the S side.
- Pen light
- WS-48B (3kHz, 0dB)
- P-4-A100 (10kHz, -10dB)

### Definition:

The following view relates to record/playback heads.

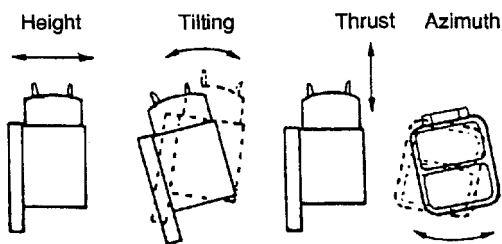

For the locations of the adjusting screws, see the view "adjustment location" in the lower right corner of Page 9.

### Procedure:

#### Pinch roller in the S side

**Note:** It should be adjusted only when the pinch roller in the S side is replaced.

1. Mount the mirror cassette and set the equipment to playback state.
2. Check that the tape is curled in the pinch roller guide or the guide of the record/playback heads.  
If curled, remedy it by rotating the tape curl adjusting screw **H**. At that time, check that the tape runs near the center part of the erase heads.

## Record/playback heads

**Note:** The heads should be adjusted only when the record/playback head is replaced.

1. Mount the mirror cassette and set the equipment to playback state.
2. (Height adjustment) Check that the tape is curled in the tape guide of the heads. If curled, rotate screws **A**, **B** and **C** in the same angle and move the entire heads parallel. Check the mirror cassette where there is curling and, when curling exists in the lower side (actually in the deep side), tighten all screws slightly. If curled in the upper (your) side, loosen them.

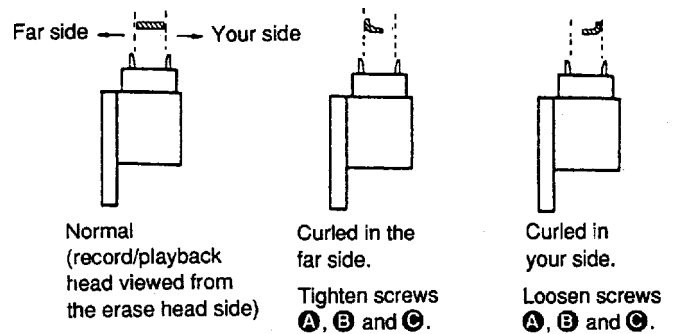

3. (Adjustment of tilting) Adjust back tension to 0 still in playback state (loosen the tape by rotating the reel in the S side using a small tip such as a pencil), and check that there is no curling or snaking (up or down) in the guide of the record/playback heads. Snaking of the tape may occur only within the range of a difference in the widths of the tape and the tape guide (it curls when rate slacks more than the range). Therefore, carefully check it because it may often be overlooked.  
If the tape is snaking, rotate screws **B** and **C** in the same angle and change the tilting of the heads. Tighten or loosen the screws to remedy up or down snaking, respectively.
4. Repeat the adjustment 2 and 3 again and converge the height and tilting to suitable positions.
5. (Tentative adjustments of azimuth) Demagnetize and clean the heads and playback WS-48B (3kHz, 0dB).  
Rotate the screw **C** so that the pointer or the level meter of the set or connected to LINE OUT becomes maximum. If the screw is rotated more than 1/2 turn, repeat the adjustments again from 1.
6. (Checking of tape pass) Connect an oscilloscope to LINE OUT, replay P-4-A100 (10kHz, -10dB) to describe Lissajous' figures.  
At about 20 seconds after beginning playback (the tension in the loop becomes stable), check that the variation of the Lissajous' figures occur within  $\pm 90^\circ$  (more preferably within  $\pm 45^\circ$ ). If beyond  $\pm 90^\circ$ , adjustments of tilting or height will not be complete, so finely adjust the equipment again from 1.



Standard adjustment tape  
P-4-A100  
(10kHz, -10dB)

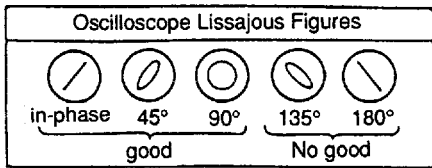
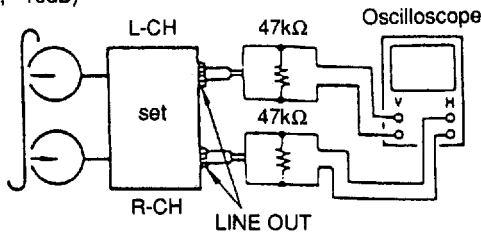

### Erase heads

**Note:** The heads should be adjusted only when the erase head is replaced.

1. Mount the mirror cassette and set the equipment to playback state.
2. (Azimuth adjustments) Adjust screws **E** or **F** so that the tape runs as parallel to the erase heads as possible.

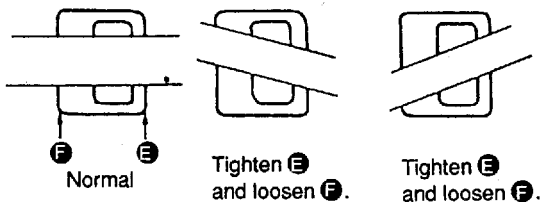

(Erase head viewed in the mirror cassette)

3. (Height adjustment) Rotate screws **D**, **E** and **F** in the same angle so that the widths of erase heads seen in the upper and lower sides of the tape become essentially the same. If the width in the upper or lower side is larger, tighten or loosen the screws, respectively.

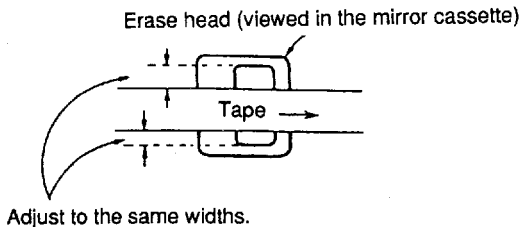

4. (Adjustments of tilting) Adjust back tension to 0 still in playback state and check that there is no snaking in the erase heads and pinch roller guide in the S side. If there is, change tilting by rotating the screw **D**. When the tape moves up or down in the mirror tape, tighten or loosen the screw, respectively.

5. Repeat the adjustments again from 2. and converge the height and tilting to more suitable values. And, check that there are no tape curls in the pinch roller guide and the guide of the record/playback heads.
6. (Adjustments of thrust) Slightly loosen the screw **G** and finely adjust it so that the tape smoothly runs over the entire surfaces of the heads by adjusting the thrust of the erase heads to an optimum value relative to the tape.

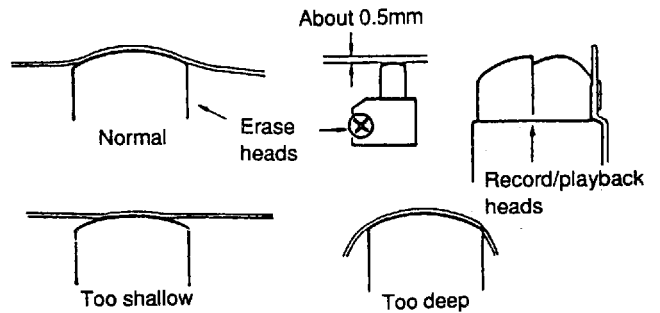

### Checking

1. Check that the tape smoothly runs over the entire tape pass without curling or snaking.
2. After the adjustments, apply the locking compound to the screws adjusted (apply the compound to the screw **C** only after the final azimuth adjustments are completed).

### Adjustment Location:

The following views relate to those in the mirror cassette (upper) and MD viewed from your side (lower).

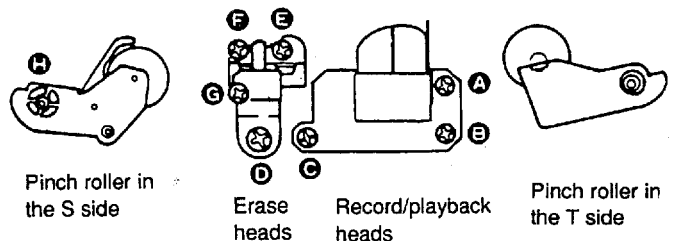
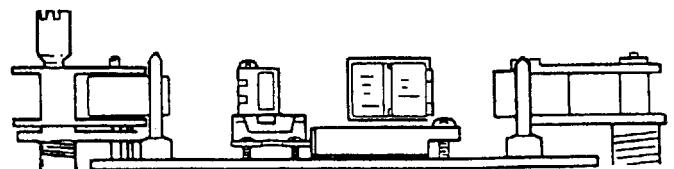

### Torque Adjustment

1. Load the torque measuring tape CQ-102C, and play back. Adjust RV801 so that the torque meter reading is  $40 \pm 5g \cdot cm$ . ( $0.556 \pm 0.069 \text{ oz} \cdot \text{inch}$ )
2. After adjustment, measure back tension and FF/REW torque, and make sure that measured data satisfies the specification.

Torque	Torque meter	Meter reading
FWD	CQ-102C	35 - 45g·cm (0.49 - 0.62 oz · inch)
FWD back tension	CQ-102C	7 - 11g·cm (0.10 - 0.15 oz · inch)
FF/REW	CQ-201B	65 - 90g·cm (0.91 - 1.25 oz · inch)

## SECTION 4

### ELECTRICAL ADJUSTMENTS

**• Note**

1. Perform adjustment in the order listed below. (As a rule, adjust the record system after adjustment of playback system has been completed.)
2. Adjust and measure both channels otherwise specified.
3. To perform simultaneous record and playback, select recording mode, and set MONITOR switch to TAPE, then play back immediately the recorded signal to take out from LINE OUT.

**• Switch position**

DOLBY NR ..... OFF  
 MPX FILTER ..... OFF  
 TIMER ..... OFF  
 MONITOR ..... TAPE  
 HX PRO ..... OFF  
 CALIBRATION ..... OFF  
 BIAS ..... CENTER CLICK  
 REC LEVEL ..... CENTER CLICK  
 REC EQ ..... CENTER CLICK

**• Standard Record**

Adjust the REC LEVEL (RV501) controls so that the I/O signal levels specified below can be attained.

**Record Mode**

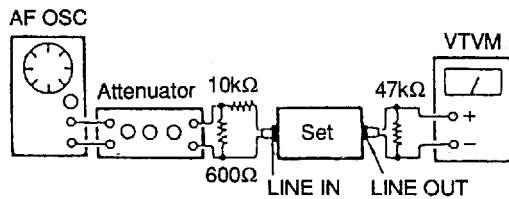

0dB=0.775V

**Standard Input Level**

Input pin	LINE IN
Signal source impedance	10kΩ
Input signal level	0.5V (-3.8dB)

**Standard Output Level**

Output pin	LINE OUT
Load impedance	47kΩ
output signal level	0.5V (-3.8dB)

**Test Tape**

Type	Signal	Used for
WS-48B	3kHz, 0dB	Tape speed/WOW check
P-4-A100	10kHz, -10dB	Azimuth adjustment
P-4-L300	315Hz, 0dB	PB level adjustment

**Tape Speed/WOW check**

**Procedure:**

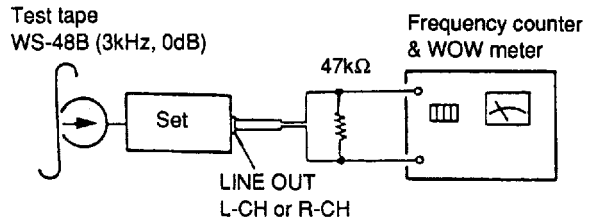

1. Play back the top of test tape to measure its output frequency and WOW value.
2. Invert test tape and perform same measurement, then check for difference between top and end of tape.

**Specification :**

Tape speed deviation : within 2,990 to 3,010Hz  
 Tape speed fluctuation : within 2,990 to 3,010Hz  
 WOW (WRMS) : 0.047% less

**MPX Filter Check**

**Condition :**

DOLBY NR switch : OFF  
 MPX FILTER switch : OFF  
 REC LEVEL control : Standard record  
 MONITOR switch : SOURCE

**Procedure :**

1. Mode : stop

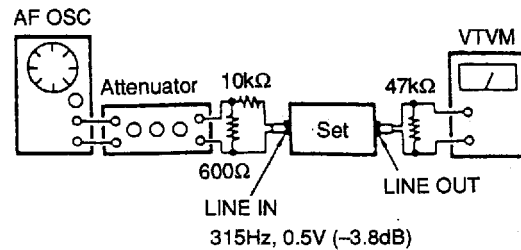

2. Applying 19kHz, 0.5V (-3.8dB) signal, measure the LINE OUT level.

**Specification :**

DOLBY NR switch : Either B, C or S  
 MPX FILTER switch : ON, LINE OUT level must be,  
 315Hz : within 0.44 to 0.56V (within -4.8 to -2.8dB)  
 19kHz : 15.8mV (-33.8dB) or less

### Record/Playback Head Azimuth Adjustment

Procedure :

1. Mode : FWD playback

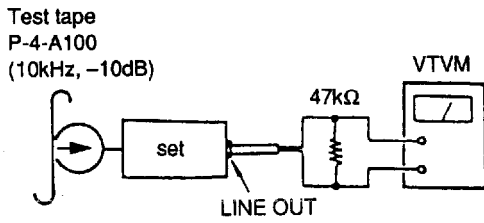

2. Turn the adjustment screw for the maximum output levels. If these levels do not match, turn the adjustment screw until both of output levels match together within 1dB.

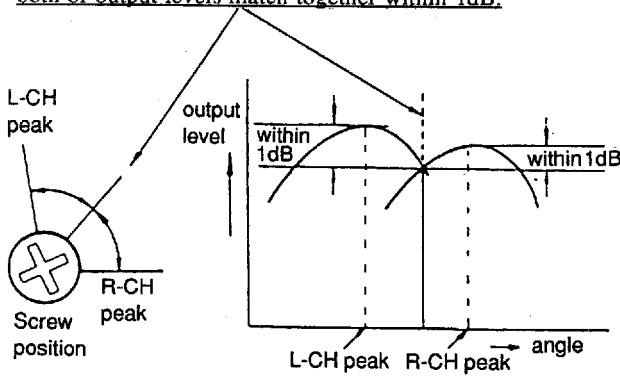

3. Phase Check  
Mode : playback

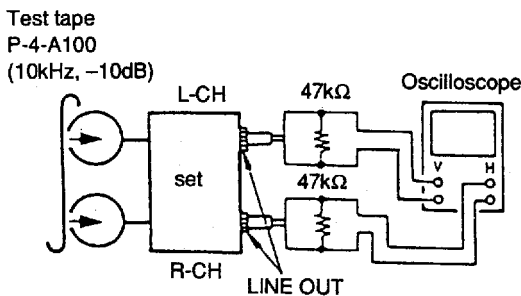

4. Confirm that the phase difference between L-CH and R-CH is in-phase to 90°.

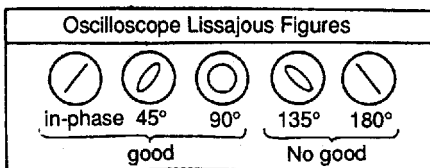

Adjustment Location :

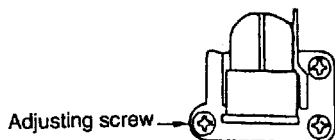

### Playback Level Adjustment

Procedure :

1. Mode : Playback

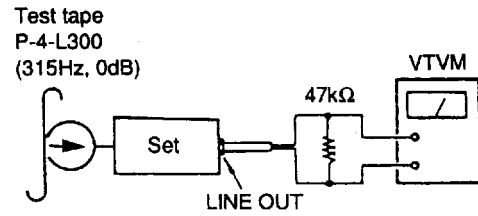

2. Adjust the RV101 (L-CH) and RV201 (R-CH) to satisfy the following specification.

Adjustment Value :

LINE OUT level : 0.3 to 0.34V (-8.2 to -7.2dB)

Level difference between channels : within 0.5dB

Confirm that the LINE OUT level does not change when playback and stop are repeated.

### Erase Current Adjustment

Procedure :

1. Mode : record

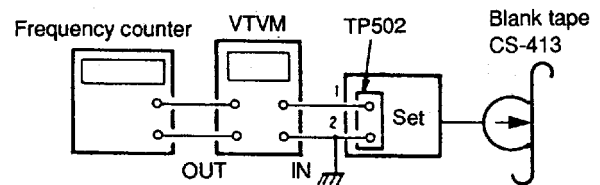

2. Adjust RV506 so that VTVM reading is 110mV (erase current 110mA).
3. At this time, confirm oscillation frequency.

Adjustment Value :

Erase current :  $110^{+0}_{-5}$  mA

Oscillation frequency :  $160 \pm 6$  kHz

**Bias Consumption Current Adjustment**

**Note :** The bias consumption current must be adjusted before adjusting the record bias. Retry record bias adjustment after the bias consumption current is adjusted.

**Procedure :**

1. Set semi-fixed resistors RV104 (L-CH), RV204 (R-CH) and RV505 for record bias adjustment to mechanical center, and select the recording mode without applying a signal.
2. Adjust T101 (L-CH) and T201 (R-CH) so that the digital voltmeter reading becomes minimum.

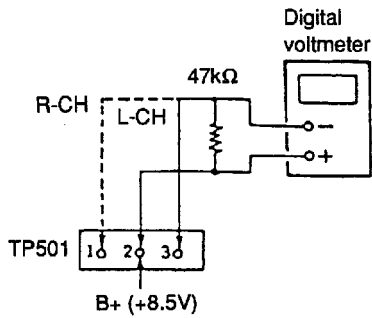

**Specification :** 120mV or less  
(This value is measured using CS-413 after bias adjustment)

**Bias and Recording level adjustment (HX PRO : ON)**

**Condition :**  
REC LEVEL control : Specified recording position (page 10)

**Procedure :**

1. Mode : simultaneous record and playback

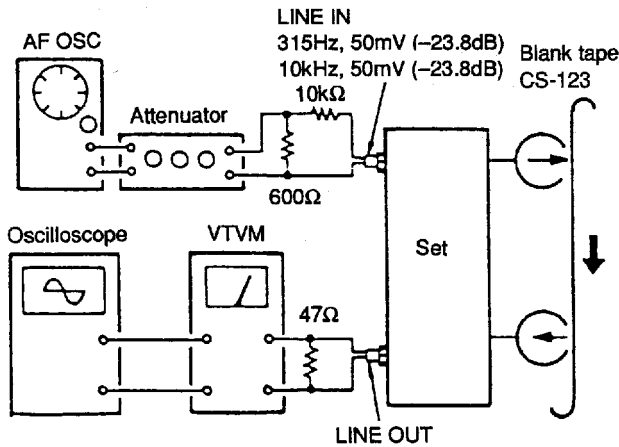

2. Adjust the following controls so that the minimum output becomes the specified output level.
  - (1) RV104 (L-CH) and RV204 (R-CH) ..... Bias adjustment
  - (2) RV103 (L-CH) and RV203 (R-CH) ..... Recording level adjustment

**Adjustment Value :**

- (1) Level of 10kHz against 315Hz :  $0 \pm 0.3\text{dB}$
- (2) 315Hz level : 48.3 to 51mV (-24.1 to -23.5dB)

**Bias Adjustment (HX PRO : OFF)**

**Condition :**  
REC LEVEL control : Specified recording position (page 10)  
HX PRO switch : OFF

**Procedure :**

1. Mode : simultaneous record and playback

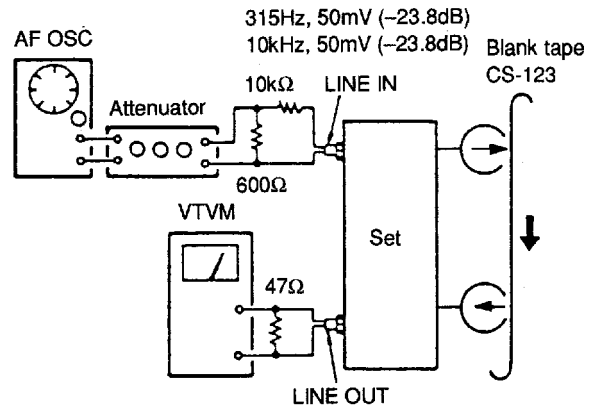

2. Adjust RV105 (L-CH) and RV205 (R-CH) so that 10kHz playback output is  $0 \pm 0.3\text{dB}$  relative to the 315Hz output.

**Metal Bias Adjustment**

**Condition :**  
REC LEVEL control : Specified recording position (page 10)

**Procedure :**

1. Mode : simultaneous record and playback

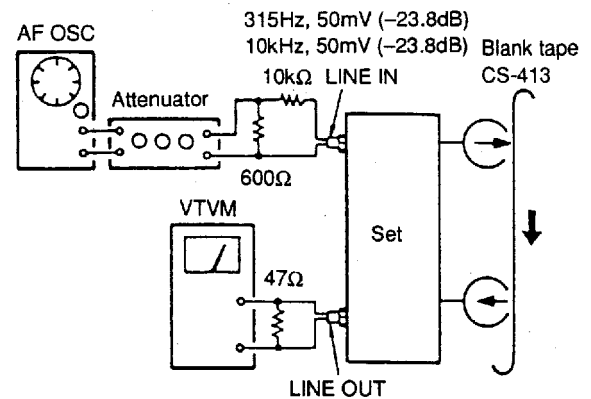

2. Adjust RV505 so that 10kHz R-CH output is  $0 \pm 0.3\text{dB}$  relative to the 315Hz output.

**Calibration Adjustment**

Condition :

CALIBRATION switch : ON

TP801 : The state of short-circuit

Adjustment method (Oscillation input level) :

1. Short-circuit the test point TP801 of system control (A) board.
2. Adjust RV904 (HIGH), RV905 (MID) and RV906 (LEVEL) to become the level meter as the following display.



3. As for HIGH and MID, the segment with  $\triangle\triangledown$  mark in the left side should be lit. (approve of flashing)  
And when the left segment is flashing, the right segment is approved of flashing.
4. As for LEVEL,  $\blacksquare$  mark should be lit. (Both ends are approved of flashing.)
5. Release the short-circuit of TP801.

Adjustment Location :

**AUDIO (A) BOARD** — Component side —

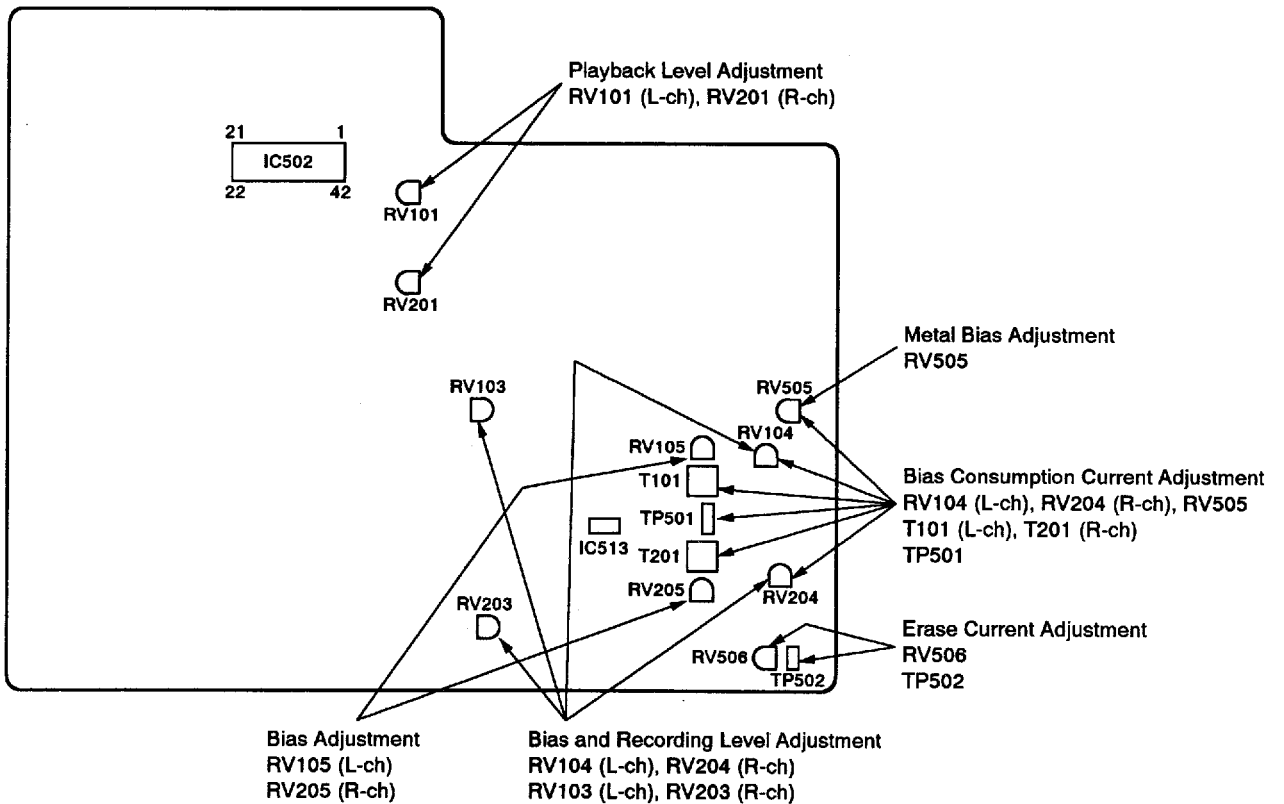

**SYSTEM CONTROL (A) BOARD — Component side —**

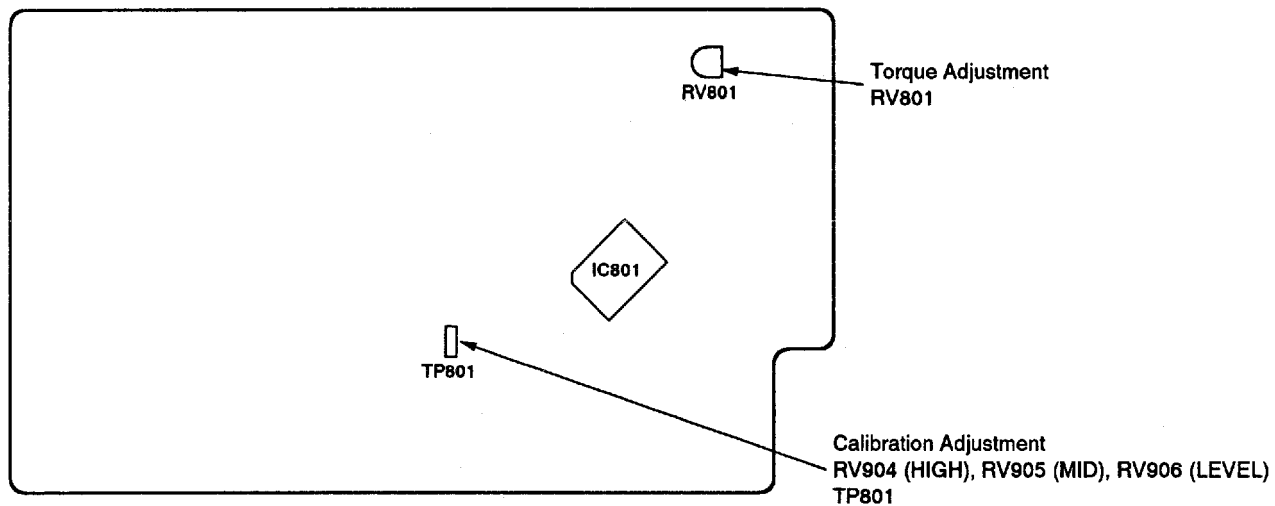

**SYSTEM CONTROL (F) BOARD — Component side —**

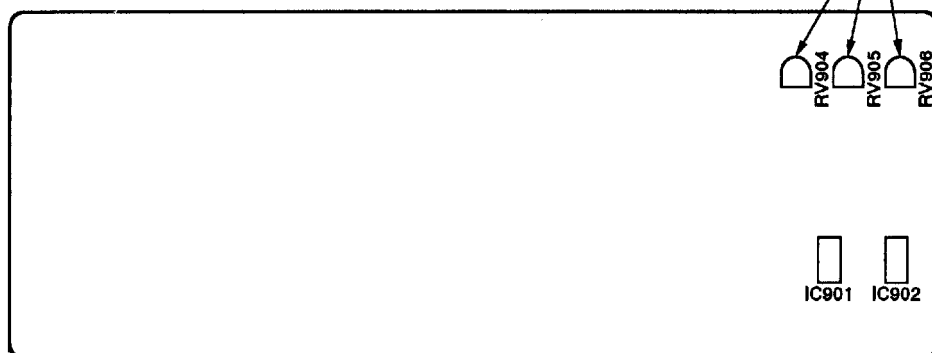

## SECTION 5 DIAGRAMS

### 5-1. IC PIN FUNCTIONS

• IC801 M38172M4-133FP

Pin No.	Pin Name	I/O	Function																																													
1	EQ VOL	I	Calibration volume (EQ) data input																																													
2	LEVEL VOL	I	Calibration volume (LEVEL) data input																																													
3	T-PULSE	I	Mechanism deck take-up reel table sensor pulse input																																													
4	S-PULSE	I	Mechanism deck supply reel table sensor pulse input																																													
5	SYNC	I	Serial timing clock input																																													
6	SR-CLK	I	Serial clock input																																													
7	SR-OUT	O	Serial clock data output																																													
8	SR-IN	I	Serial clock data input																																													
9	NC	I	Not used (open)																																													
10	M-CLK	I/O	Memory clock input																																													
11	M-DATA	I/O	Memory data input																																													
12	NC	-	Not used (open)																																													
13	$\overline{\text{SERVO}}$	O	Eject motor control L: EJECT																																													
14	$\overline{\text{FAST TRQ}}$	O	Motor speed control L: FAST																																													
15	$\overline{\text{PLAY TRQ}}$	O	Play motor control L: PLAY																																													
16	REEL FWD	O	Reel motor FWD control L: FWD																																													
17	REEL RVS	O	Reel motor REV control L: REV																																													
18	ASIST UP	O	Assist motor UP control L: UP																																													
19	ASIST DOWN	O	Assist motor DOWN control L: DOWN																																													
20	METAL HOLE	I	Mechanism deck METAL SW (S1007) input H: Metal tape, L: Normal or CrO <sub>2</sub> tape																																													
21	$\overline{\text{HALF}}$	I	Mechanism deck HALF SW (S1006) input L: Tape is loaded																																													
22	70 $\mu$ HOLE	I	Mechanism deck 70 $\mu$ SW (S1008) input H: 70 $\mu$ S L: 120 $\mu$ S (Constant when playback EQ)																																													
23	$\overline{\text{REC TAB}}$	I	Mechanism deck FWD TAB (S1005) input L: There is Rec protector																																													
24	NC	-	Not used (open)																																													
25	SIRCS	I	SIRCS signal input																																													
26	PWR DET	I	Power detect H: ON																																													
27	$\overline{\text{RESET}}$	I	RESET input																																													
28	XC-IN	I	Not used (Connect to GND)																																													
29	XC-OUT	O	Not used (open)																																													
30	X-IN	I	Clock input (6MHz)																																													
31	X-OUT	O	Clock output (6MHz)																																													
32	V <sub>ss</sub>	-	GND																																													
33	NC	-	Not used (open)																																													
34	$\overline{\text{DRSW}}$	I	Mechanism deck DOOR SW (S1002) input																																													
35	$\overline{\text{CLSW}}$	I	Mechanism deck CLOSE SW (S1003) input																																													
36	OPSW	I	Mechanism deck OPEN SW (S1004) input																																													
37 to 40	PT3 to PT0	O	Rotary encoder input for mechanism deck head base position detection <table border="1" style="margin-left: 20px;"> <thead> <tr> <th></th> <th>PAUSE</th> <th>AMS</th> <th>FF/REW</th> <th>STOP</th> <th colspan="2">PLAY</th> <th colspan="2">EJECT</th> </tr> </thead> <tbody> <tr> <td>PT3</td> <td>L</td> <td>L</td> <td>L</td> <td>L</td> <td>H</td> <td>H</td> <td>H</td> <td>H</td> </tr> <tr> <td>PT2</td> <td>L</td> <td>L</td> <td>H</td> <td>H</td> <td>L</td> <td>L</td> <td>H</td> <td>H</td> </tr> <tr> <td>PT1</td> <td>L</td> <td>H</td> <td>L</td> <td>H</td> <td>L</td> <td>H</td> <td>L</td> <td>H</td> </tr> <tr> <td>PT0</td> <td>L</td> <td>H</td> <td>H</td> <td>L</td> <td>L</td> <td>L</td> <td>L</td> <td>L</td> </tr> </tbody> </table>		PAUSE	AMS	FF/REW	STOP	PLAY		EJECT		PT3	L	L	L	L	H	H	H	H	PT2	L	L	H	H	L	L	H	H	PT1	L	H	L	H	L	H	L	H	PT0	L	H	H	L	L	L	L	L
	PAUSE	AMS	FF/REW	STOP	PLAY		EJECT																																									
PT3	L	L	L	L	H	H	H	H																																								
PT2	L	L	H	H	L	L	H	H																																								
PT1	L	H	L	H	L	H	L	H																																								
PT0	L	H	H	L	L	L	L	L																																								

Pin No.	Pin Name	I/O	Function
41	NC	—	} Not used (open)
42	NC	—	
43 to 48	EQ6 to EQ1	O	Calibration EQ adjust output
49 to 53	LV5 to LV1	O	Calibration LEVEL adjust output
54 to 56	NC	O	Not used (open)
57	S-TAPE	O	DOLBY S monitor output
58	NORM- TAPE	O	DOLBY B, C monitor output
59	SOURCE	O	Source ON/OFF control H: ON
60	DOLBY ON	O	DOLBY B ON/OFF control H: ON
61	DOLBY C	O	DOLBY C ON/OFF control L: ON
62	DOLBY S	O	DOLBY S ON/OFF control H: ON
63	FILTER	O	MPX FILTER ON/OFF control H: ON
64	HX PRO	O	HX PRO ON/OFF control H: ON
65	LINE MUTE	O	LINE MUTE ON/OFF control L: ON
66	REC MUTE	O	REC MUTE ON/OFF control L: ON
67	BIAS	O	BIAS ON/OFF control H: ON
68	AMS MODE	O	AMS MODE ON/OFF control L: ON
69	TYPE 1	O	REC equalizer switching output H: TYPE 1
70	TYPE 2	O	REC equalizer switching output H: TYPE 2
71	TYPE 4	O	REC equalizer switching output H: TYPE 4
72	CAL MODE	O	Calibration control output
73	Vcc	—	Power supply (+5V)
74	Vee	—	Power supply (–25V)
75	AVss	—	GND
76	Vref	—	Reference voltage (+5V)
77	AMS IN	I	AMS signal input
78	LINE	I	TEST TERMINAL L: TEST MODE
79	KEY-IN	I	Key input
80	DOLBY SW	I	DOLBY SW detection input



• IC851 M38122M2-069SP

Pin No.	Pin Name	I/O	Function
1	Vcc	–	Power supply (+5V)
2	Vee	–	Power supply (–25V)
3	AVss	–	GND
4	Vref	–	Reference voltage (+5V)
5	KEY-X	I	Key switch input (A/D) OPEN/CLOSE, STOP, REW, FF, REC
6	KEY-Y	I	Key switch input (A/D) PLAY, PAUSE, REW, AMS, FF, AMS, REC MUTE
7	KEY-Z	I	Key switch input (A/D) RESET, MEMORY
8	TIM-SW	I	TIMER switch input (A/D) PLAY, OFF, REC
9	NC	–	Not used (open)
10	LEVEL-SW	I	Level meter input (Calibration)
11	METER-R	I	Level meter input (R CH)
12	METER-L	I	Level meter input (L CH)
13	REC LED	O	LED lights (REC)
14	PAUSE LED	O	LED lights (PAUSE)
15	PLAY LED	O	LED lights (PLAY)
16	SR-CLK	I	Serial clock input
17	SR-OUT	O	Serial data output
18	SR-IN	I	Serial data input
19 to 25	NC	–	Not used (open)
26	SYNC	I	Serial timing clock input
27	RESET	I	Reset signal input
28, 29	NC	–	Not used (open)
30	XI	I	Clock input (6MHz)
31	XO	O	Clock output (6MHz)
32	Vss	–	GND
33	GRID5	O	} FL tube grid output
34	GRID4	O	
35	GRID3	O	
36	GRID1	O	
37	GRID2	O	
38	SEG A	O	} FL tube segment output
39 to 64	SEGz to SEGa	O	

**5-2. CIRCUIT BOARDS LOCATION**

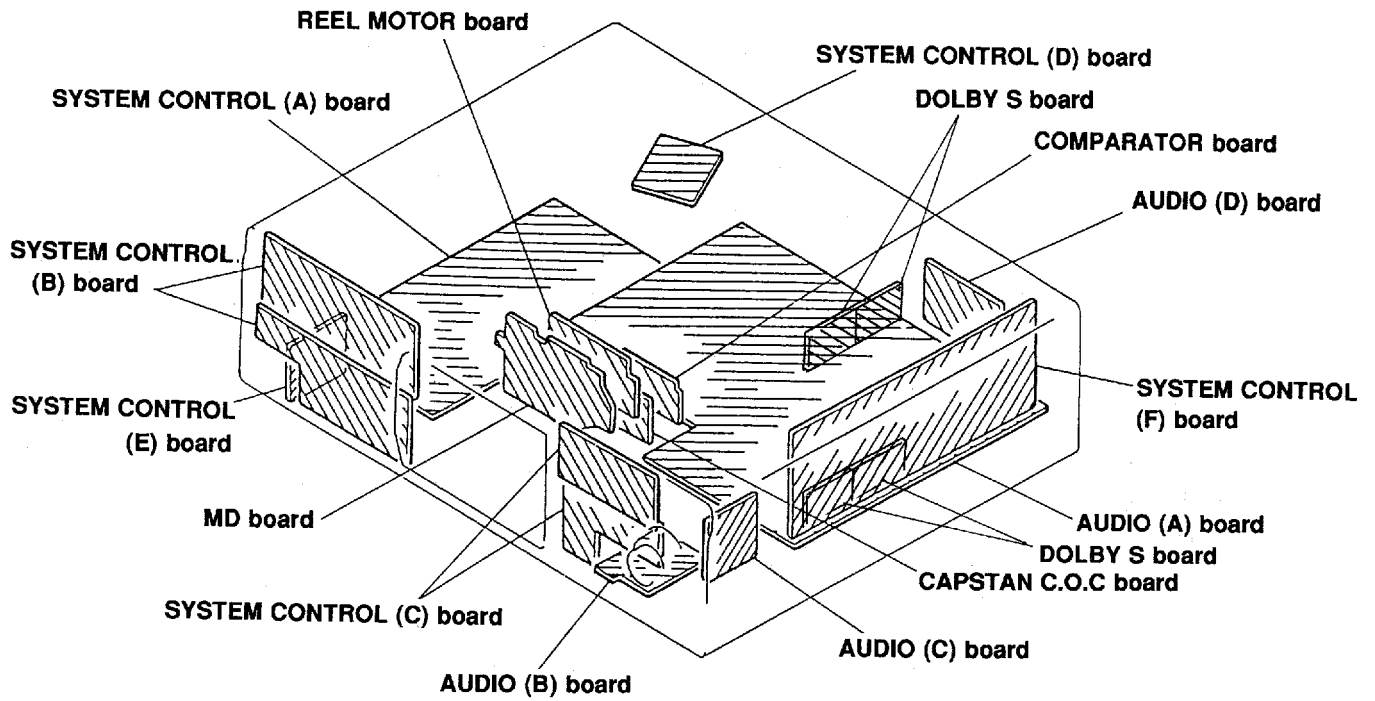

**NOTE :** AUDIO (A)/ (B)/ (C)/ (D) and DOLBY S board are including in AUDIO board.  
 SYSTEM CONTROL (A)/ (B)/ (C)/ (D)/ (E)/ (F) are including in SYSTEM CONTROL board.

5-3. BLOCK DIAGRAM

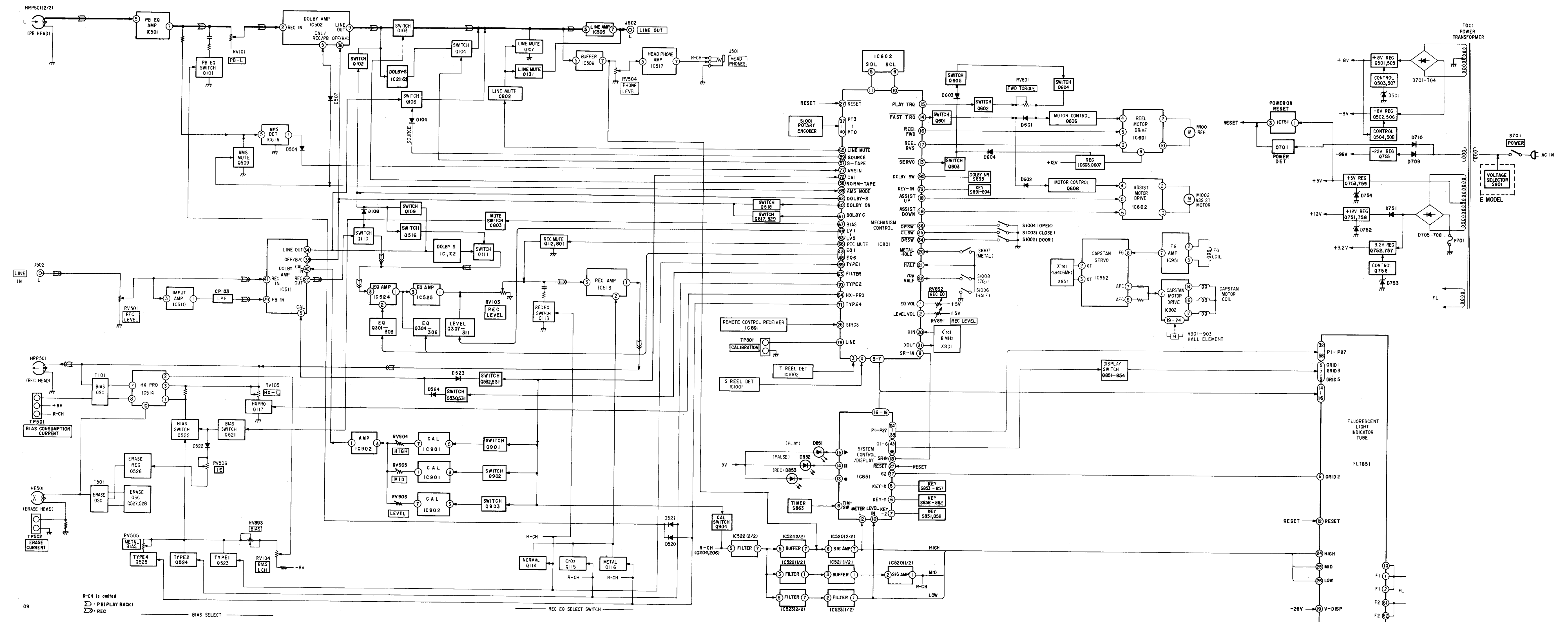

5-4. PRINTED WIRING BOARD — AUDIO SECTION —  
 • See page 18 for Circuit Boards Location.

• Semiconductor Location

Ref. No.	Location	Ref. No.	Location
D101	J-7	Q115	D-13
D102	J-7	Q116	D-13
D104	I-7	Q117	D-15
D108	D-12	Q131	F-7
D109	E-12	Q201	G-12
D201	H-7	Q202	G-8
D202	G-7	Q203	H-7
D204	G-7	Q204	G-7
D208	C-12	Q206	G-7
D209	B-12	Q207	G-7
D501	H-16	Q209	C-11
D504	F-9	Q210	D-12
D507	G-11	Q211	B-12
D508	I-8	Q212	C-13
D509	H-8	Q213	C-13
D516	C-12	Q214	C-13
D517	E-12	Q215	C-13
D520	F-13	Q216	C-13
D521	F-13	Q217	C-15
D522	B-16	Q231	F-7
D523	C-7	Q501	H-15
D524	C-7	Q502	F-15
		Q503	H-16
		Q504	F-16
IC1	C-21	Q505	H-16
IC2	G-20	Q507	H-16
IC501	H-13	Q508	G-16
IC502	I-10	Q509	G-12
IC505	I-7	Q512	J-8
IC506	F-8	Q513	H-8
IC510	C-7	Q514	C-12
IC511	C-9	Q515	E-12
IC513	D-14	Q516	E-10
IC514	D-16	Q517	E-9
IC516	F-10	Q518	E-10
IC517	J-3	Q521	D-17
Q101	H-12	Q522	D-17
Q102	J-8	Q523	E-16
Q103	J-7	Q524	E-16
Q104	J-7	Q525	E-16
Q106	I-7	Q526	B-16
Q107	F-7	Q527	B-15
Q109	E-11	Q528	B-15
Q110	D-12	Q529	E-9
Q111	E-12	Q530	D-7
Q112	D-12	Q531	D-7
Q113	D-13	Q532	C-7
Q114	D-13	Q533	C-7

Note:  
 • — : parts extracted from the component side.  
 • ● : Through hole.  
 • ■ : Pattern from the side which enable seeing.

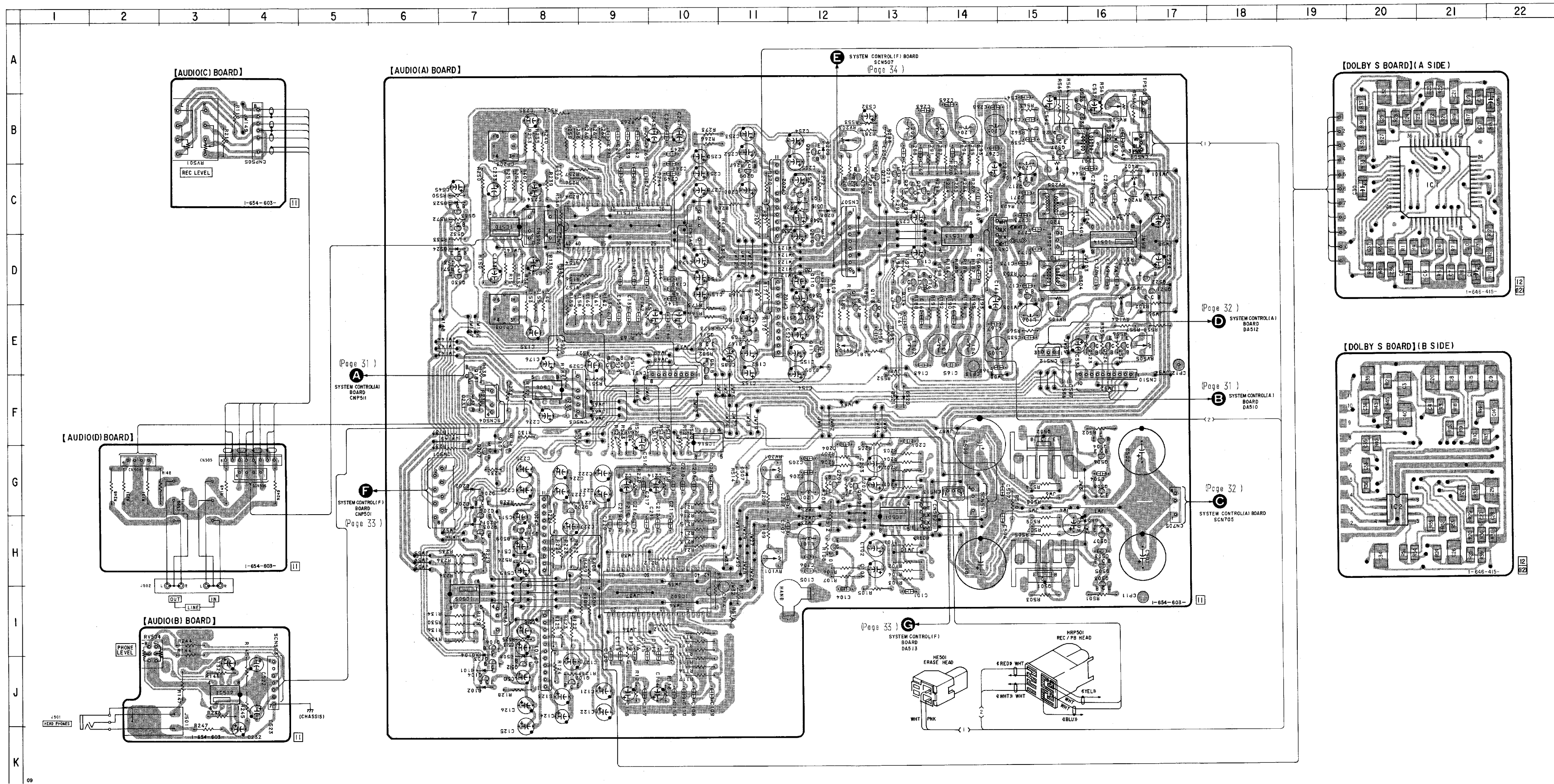

5-5. SCHEMATIC DIAGRAM — AUDIO SECTION —  
• See page 42 for IC Block Diagrams.

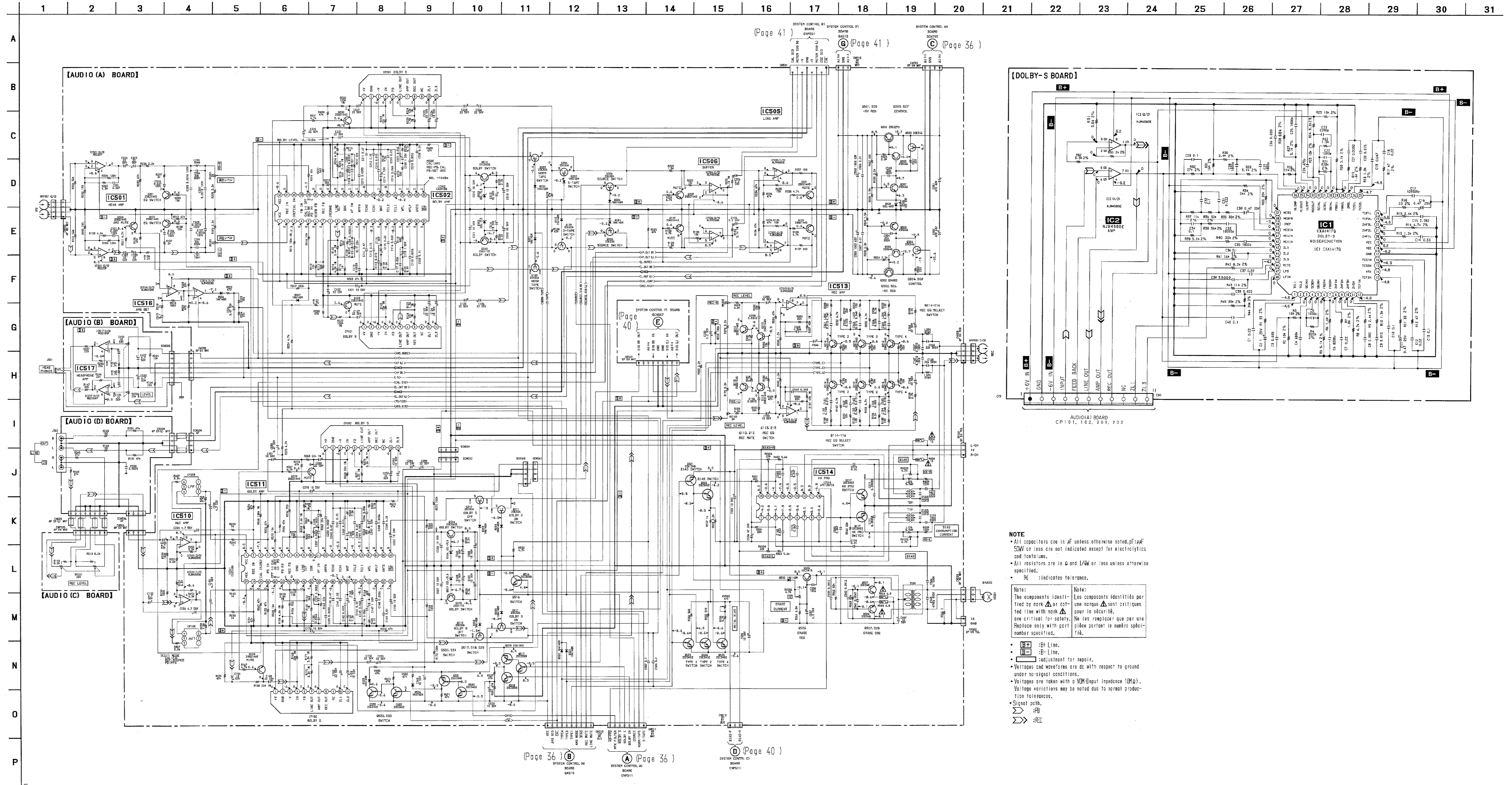

**NOTE**

- All capacitors are in  $\mu\text{F}$  unless otherwise noted, pF =  $\mu\text{F}$  / 100.
- 50W or less are not indicated except for electrolytics and tantalums.
- All resistors are in  $\Omega$  and  $1/\text{W}$  or less unless otherwise specified.
- % indicates tolerance.

**Note:**  
The components identified by mark  $\Delta$  or circled  $\Delta$  are critical for safety. Replace only with part number specified.

**Note:**  
Les composants identifiés par une marque  $\Delta$  sont critiques pour la sécurité. Ne les remplacer que par une pièce portant le numéro spécifié.

- $\Delta$  -BI Line.
- $\square$  -B Line.
- $\square$  -adjustment for repair.
- Waveforms and waveforms are dc with respect to ground under no-signal conditions.
- Waveforms are taken with a VOM (input impedance 10M $\Omega$ ). Voltage variations may be noted due to normal production tolerances.
- Signal paths:
- $\rightarrow$  -FB
- $\rightarrow$  -REC

5-6. PRINTED WIRING BOARD — SYSTEM CONTROL SECTION —  
 • See page 18 for Circuit Boards Location.

• Semiconductor Location

Ref. No.	Location	Ref. No.	Location
D120	D-22	IC952	J-2
D121	D-22	IC1001	H-9
D122	D-22	IC1002	H-9
D220	C-22		
D221	C-22	Q301	F-23
D222	C-22	Q302	F-22
D514	C-21	Q303	F-22
D515	C-21	Q304	F-22
D601	B-2	Q305	F-22
D602	B-2	Q306	F-21
D603	B-3	Q307	G-21
D604	A-3	Q308	G-21
D701	B-7	Q309	G-21
D702	B-7	Q310	G-21
D703	B-8	Q311	G-21
D704	B-7	Q401	I-23
D705	C-7	Q402	I-22
D706	C-7	Q403	I-22
D707	C-6	Q404	I-22
D708	B-6	Q405	I-22
D709	D-6	Q406	I-21
D710	D-6	Q407	I-21
D751	E-7	Q408	I-21
D752	E-8	Q409	I-21
D753	D-8	Q410	I-21
D754	C-9	Q411	I-21
D756	E-6	Q601	B-2
D757	E-6	Q602	B-3
D758	D-6	Q603	B-3
D801	E-3	Q604	B-3
D851	I-16	Q605	B-3
D852	J-16	Q606	A-3
D853	J-14	Q607	B-5
D854	G-16	Q608	B-1
D855	G-16	Q701	D-5
D856	G-16	Q751	E-6
		Q752	D-9
		Q753	C-9
IC520	C-22	Q755	D-6
IC521	E-22	Q756	E-9
IC522	E-22	Q757	D-9
IC523	C-21	Q758	D-9
IC524	H-22	Q759	D-8
IC525	H-21	Q801	D-3
IC601	B-3	Q802	E-3
IC602	B-2	Q803	E-5
IC603	A-5	Q851	H-14
IC751	C-5	Q852	H-14
IC801	C-3	Q853	H-14
IC802	C-4	Q854	G-14
IC851	G-17	Q901	B-22
IC891	B-13	Q902	A-22
IC901	B-21	Q903	A-22
IC902A	A-21	Q904	E-21
IC902B	J-6		
IC951	J-3		

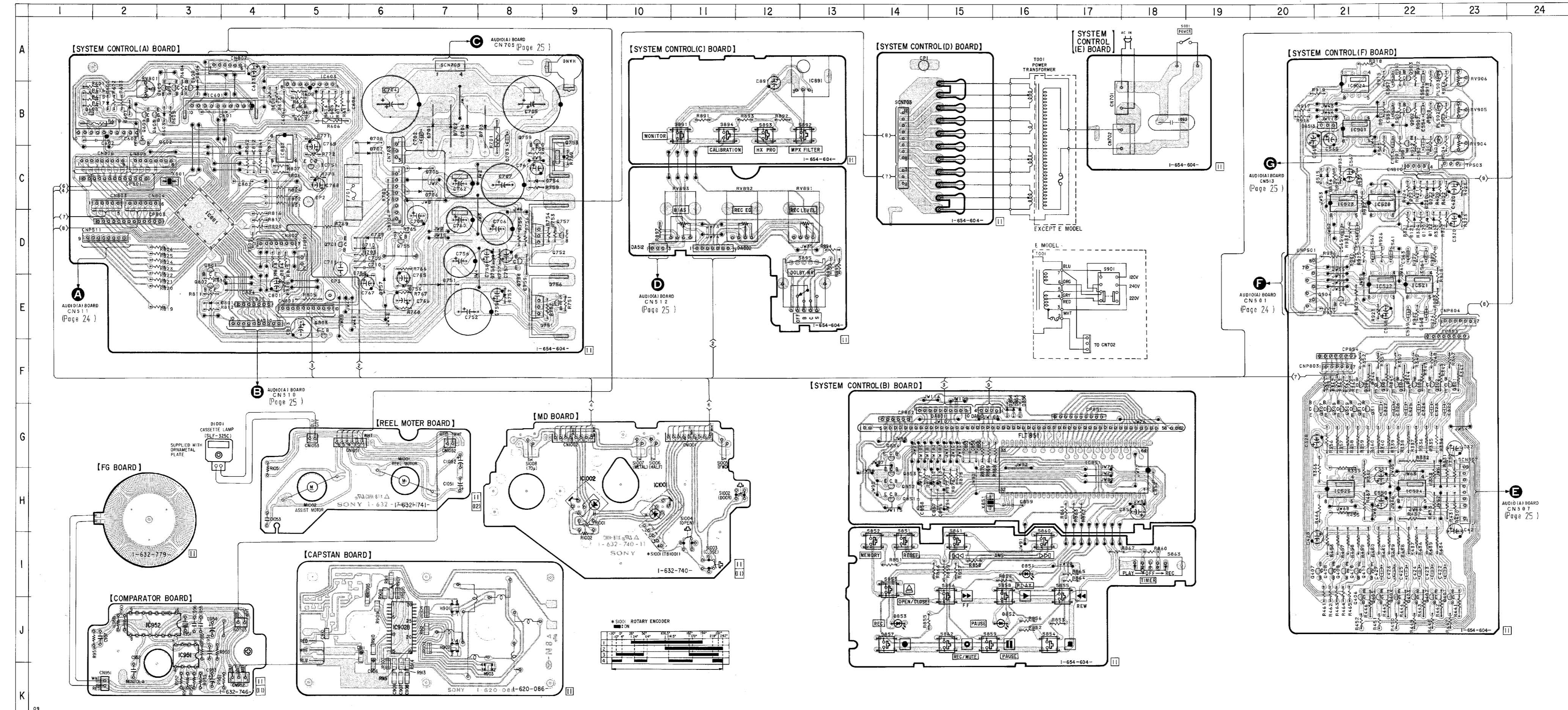

Note:  
 • ○ : parts extracted from the component side.  
 • □ : Pattern from the side which enable seeing.

5-7. SCHEMATIC DIAGRAM — SYSTEM CONTROL (1/2) SECTION —  
• See page 15 for IC Pin Function. (IC801)  
• See page 42 for IC Block Diagrams.

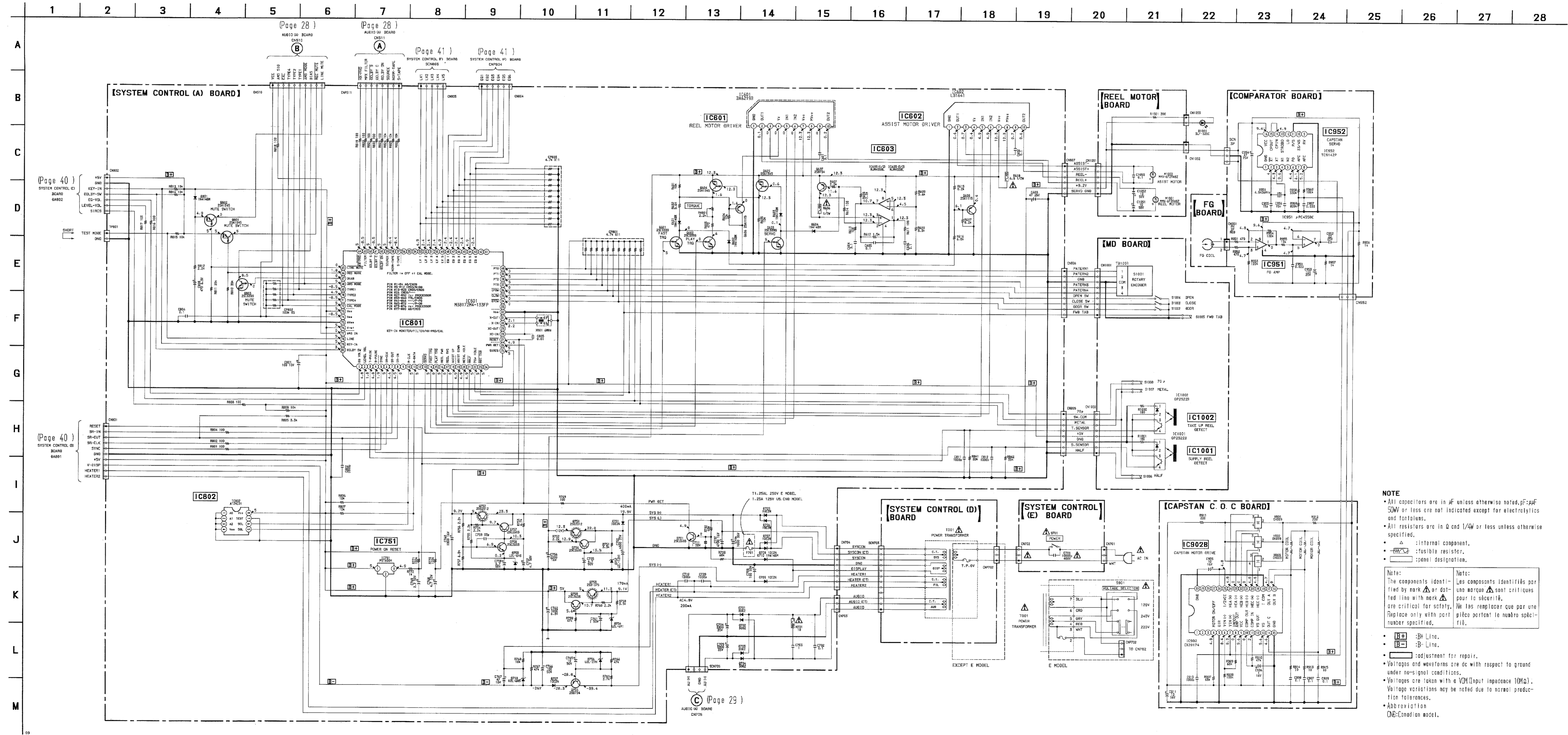

**NOTE**

- All capacitors are in  $\mu\text{F}$  unless otherwise noted; pF: pF; 50W or less are not indicated except for electrolytics and tantalums.
- All resistors are in  $\Omega$  and 1/4W or less unless otherwise specified.
- $\Delta$ : internal component.
- $\square$ : fusible resistor.
- $\square$ : panel designation.

**Note:**  
The components identified by mark  $\Delta$  or dotted line with mark  $\Delta$  are critical for safety. Replace only with part number specified.

**Note:**  
Les composants identifiés par une marque  $\Delta$  sont critiques pour la sécurité. Ne les remplacer que par une pièce portant le numéro spécifié.

- $\square$ : B-Line.
- $\square$ : B-Line.
- $\square$ : adjustment for repair.
- Voltages and waveforms are dc with respect to ground under no-signal conditions.
- Voltages are taken with a VOM (input impedance 10M $\Omega$ ). Voltage variations may be noted due to normal production tolerances.
- Abbreviation
- CND: Canadian model.

5-8. SCHEMATIC DIAGRAM — SYSTEM CONTROL (2/2) SECTION —  
• See page 17 for IC Pin Function. (IC851)

1 2 3 4 5 6 7 8 9 10 11 12 13 14 15 16 17 18 19 20 21

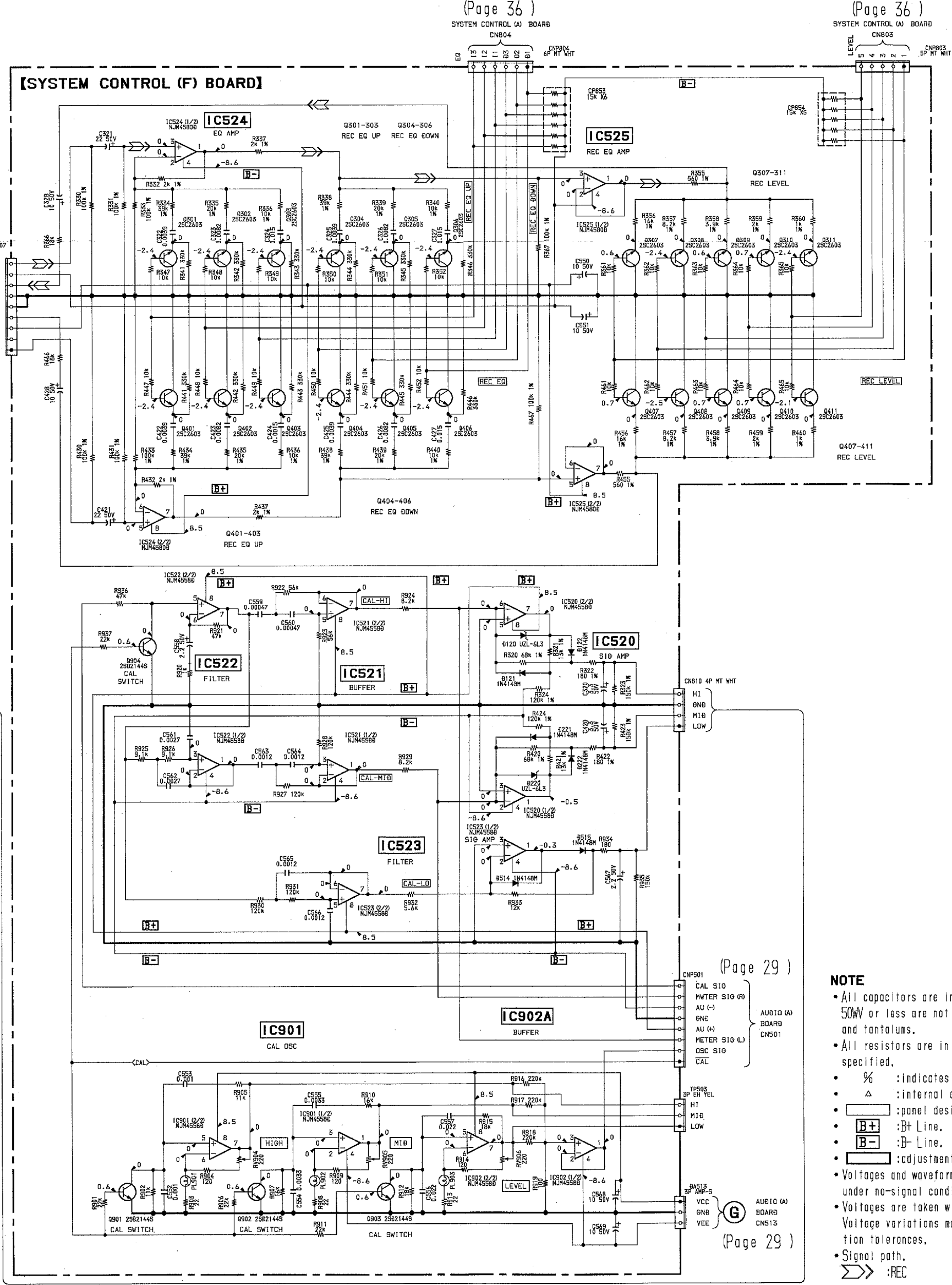
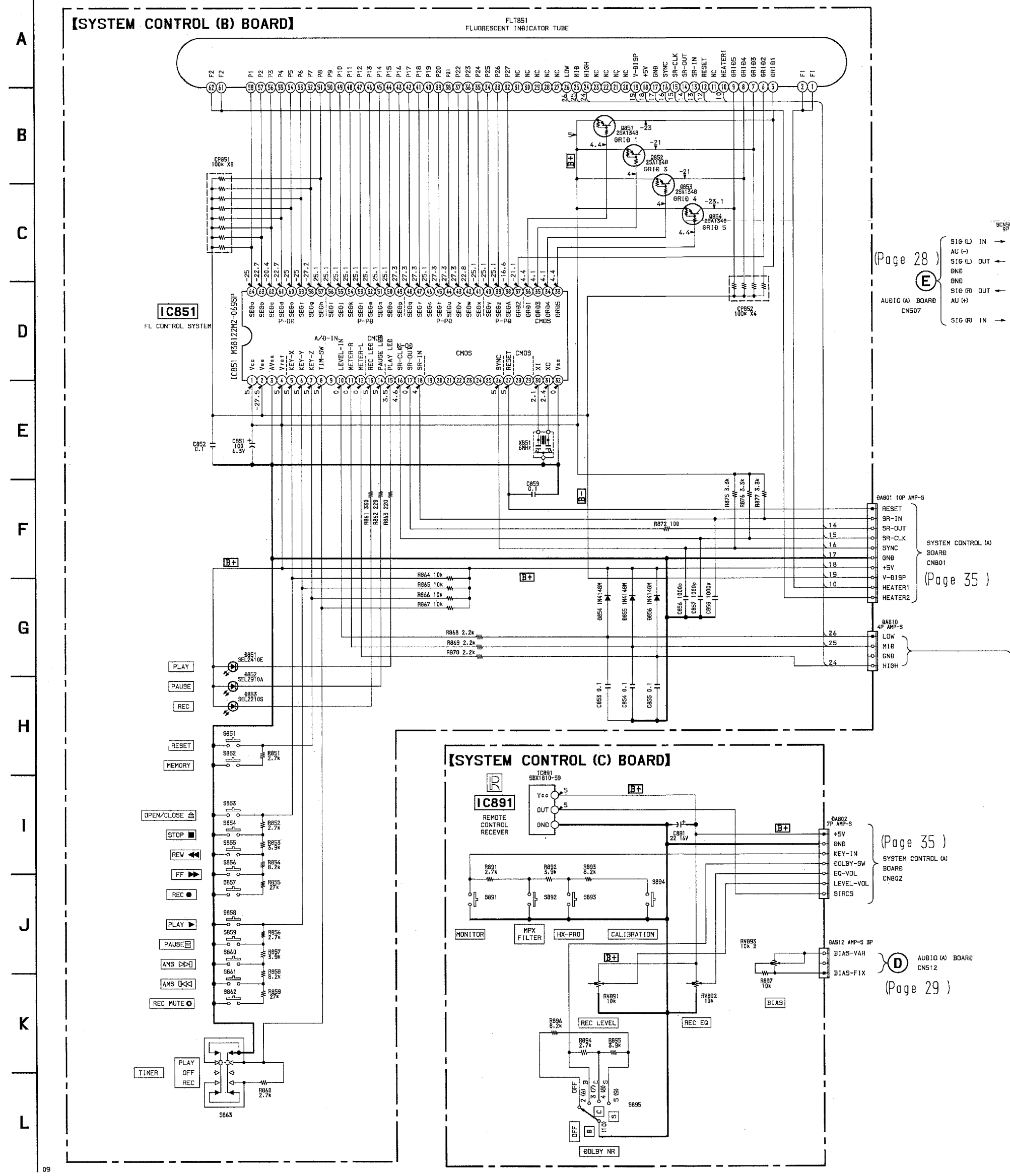

**NOTE**

- All capacitors are in  $\mu\text{F}$  unless otherwise noted,  $\text{pF} = \mu\mu\text{F}$  50WV or less are not indicated except for electrolytics and tantalums.
- All resistors are in  $\Omega$  and  $1/4\text{W}$  or less unless otherwise specified.
- % : indicates tolerance.
- $\Delta$  : internal component.
- $\square$  : panel designation.
- $\square$  : B+ Line.
- $\square$  : B- Line.
- $\square$  : adjustment for repair.
- Voltages and waveforms are dc with respect to ground under no-signal conditions.
- Voltages are taken with a VOM (input impedance  $10\text{M}\Omega$ ). Voltage variations may be noted due to normal production tolerances.
- Signal path.
- $\gg$  : REC



# 5-9. IC BLOCK DIAGRAMS

**IC1 CXA1417Q**

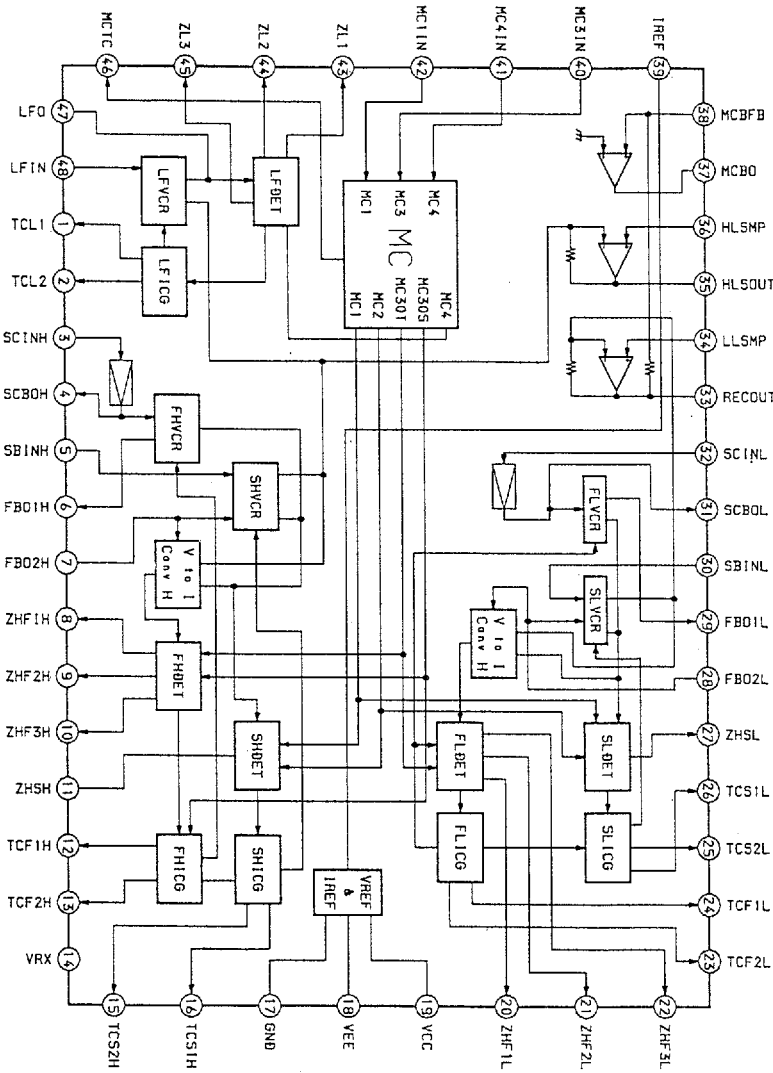

**IC502/511 CX20188**

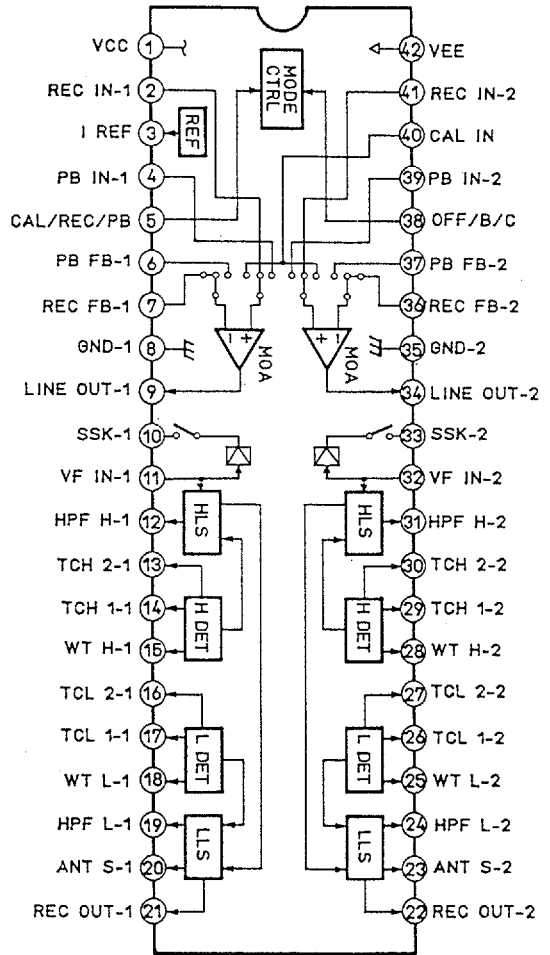

**IC514 μPC1297CA**

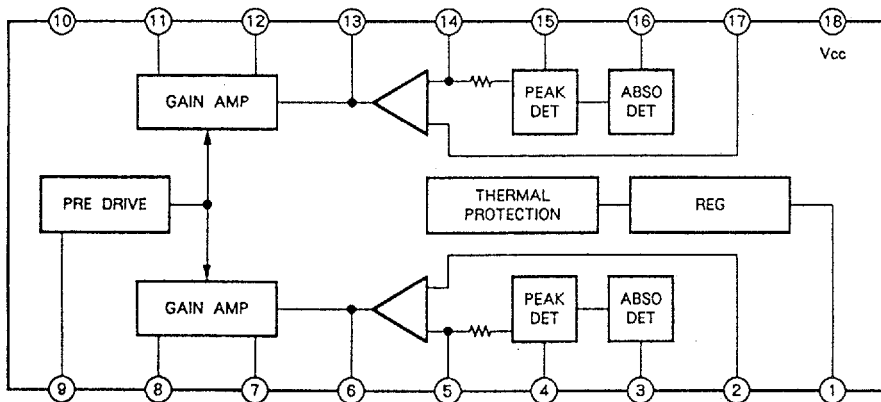

**IC601 BA6219B**

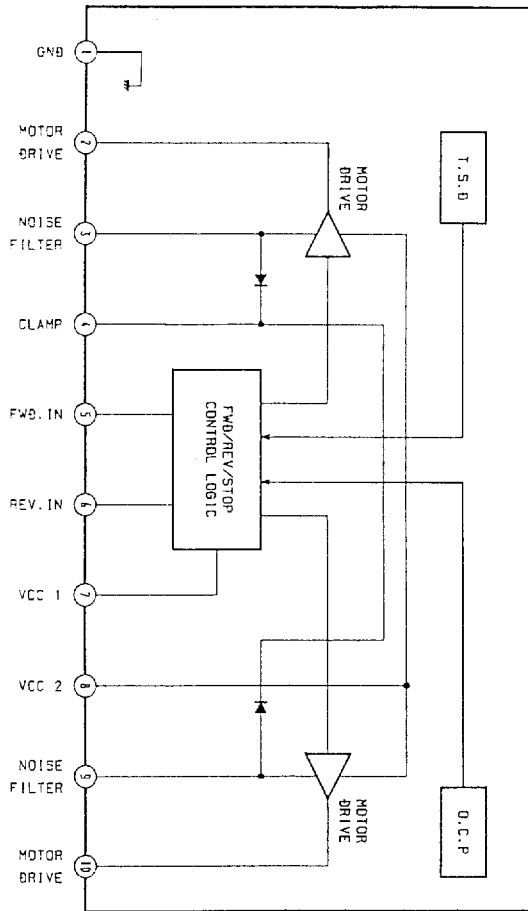

**IC602 LB1641**

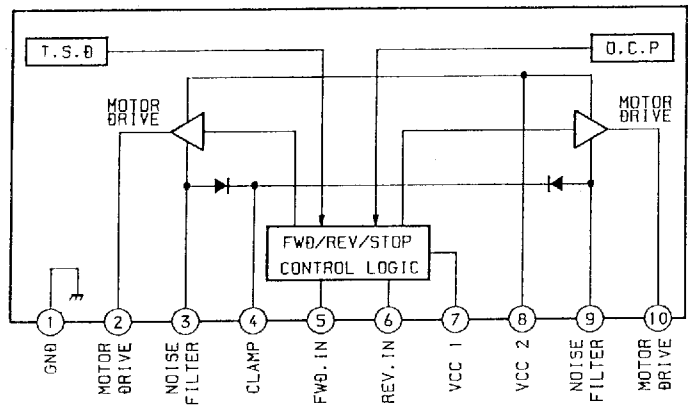

**IC802 AT24C01**

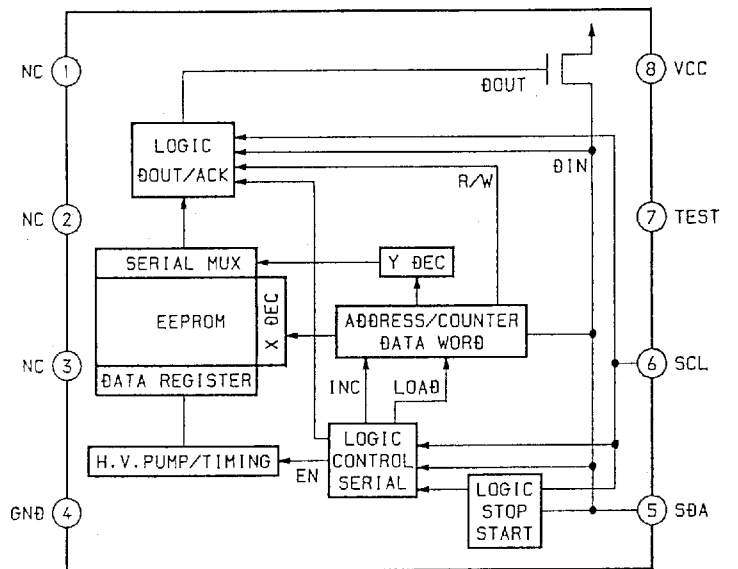

## SECTION 6 EXPLODED VIEWS

**NOTE:**

- Items marked “ \* ” are not stocked since they are seldom required for routine service. Some delay should be anticipated when ordering these items.
- The mechanical parts with no reference number in the exploded views are not supplied.
- Hardware (# mark) list and accessories and packing materials are given in the last of this parts list.
- Abbreviation  
CND : Canadian model

The components identified by mark or dotted line with mark are critical for safety. Replace only with part number specified.

Les composants identifiés par une marque sont critiques pour la sécurité. Ne les remplacer que par une pièce portant le numéro spécifié.

### 6-1. FRONT PANEL SECTION

- C SYSTEM CONTROL (C) BOARD
- E SYSTEM CONTROL (E) BOARD

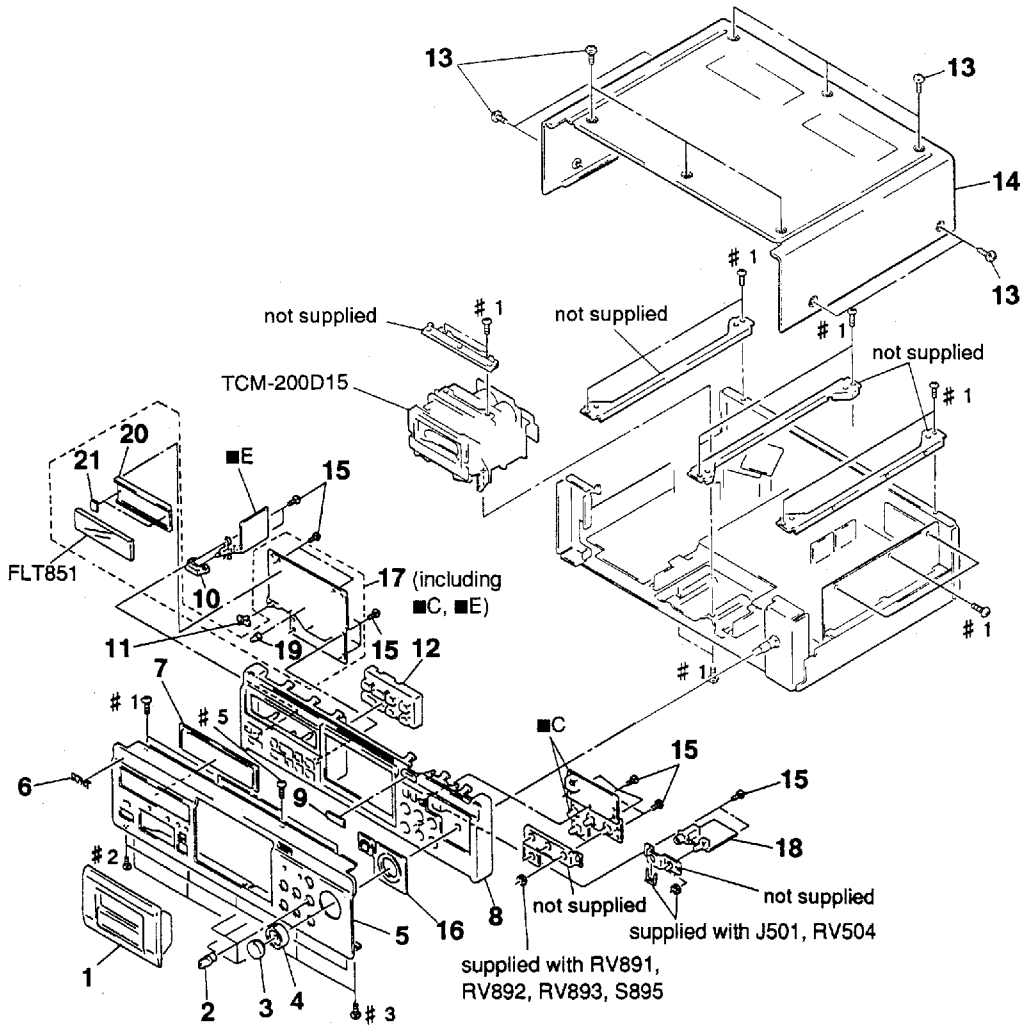

Ref. No.	Part No.	Description	Remark	Ref. No.	Part No.	Description	Remark
1	X-3369-451-1	LID ASSY, CASSETTE		13	3-704-366-01	SCREW (CASE) (M3X8)	
2	X-3362-818-1	KNOB (DIA. 12) ASSY (B), FLAT		14	3-919-386-01	CASE	
3	3-919-248-01	KNOB (R)		15	4-951-620-01	SCREW (2. 6X8), +BVTP	
4	3-919-247-01	KNOB (L)		16	3-919-384-01	ESCUTCHEON (VOL)	
5	3-919-383-01	PANEL, FRONT		* 17	A-2007-396-A	SYSTEM CONTROL BOARD, COMPLETE (E)	
6	4-942-568-01	EMBLEM (NO. 5), SONY		* 17	A-2007-398-A	SYSTEM CONTROL BOARD, COMPLETE (US, CND)	
7	3-919-224-01	WINDOW (METER)		* 18	A-2007-395-A	AUDIO BOARD, COMPLETE (E)	
* 8	3-919-385-01	PANEL (BASE)		* 18	A-2007-397-A	AUDIO BOARD, COMPLETE (US, CND)	
9	3-385-600-01	WINDOW (R) (US, E)		* 19	3-362-478-31	HOLDER (T), LED	
10	3-354-932-01	BUTTON (POWER)		* 20	3-385-607-01	HOLDER, FL TUBE	
11	3-919-257-01	KNOB (TIMER)		* 21	3-354-927-21	CUSHION	
12	X-3369-438-1	BUTTON (CONTROL) ASSY		FLT851	1-517-359-11	INDICATOR TUBE, FLUORESCENT	

## 6-2. CHASSIS SECTION

- D SYSTEM CONTROL (D) BOARD
- F SYSTEM CONTROL (F) BOARD
- C AUDIO (C) BOARD
- D AUDIO (D) BOARD
- S DOLBY S BOARD

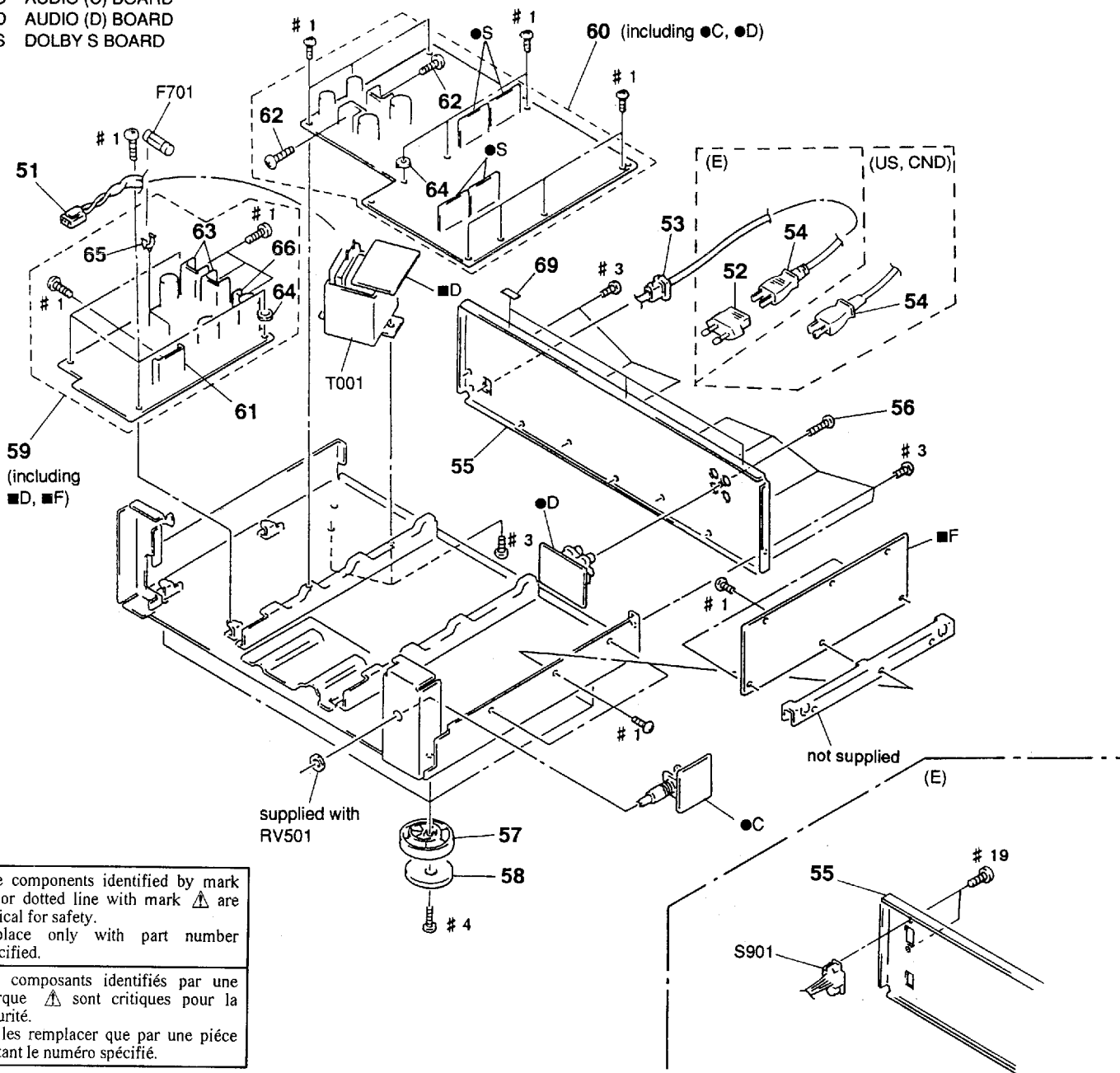

The components identified by mark  $\triangle$  or dotted line with mark  $\triangle$  are critical for safety. Replace only with part number specified.

Les composants identifiés par une marque  $\triangle$  sont critiques pour la sécurité. Ne les remplacer que par une pièce portant le numéro spécifié.

Ref. No.	Part No.	Description	Remark	Ref. No.	Part No.	Description	Remark
* 51	1-590-321-61	LEAD (WITH CONNECTOR)		* 60	A-2007-397-A	AUDIO BOARD, COMPLETE (US, CND)	
$\triangle$ 52	1-569-007-11	ADAPTER, CONVERSION 2P (E)		* 61	3-356-925-01	HEAT SINK	
* 53	3-703-244-00	BUSHING (2104), CORD (US, CND)		* 62	2-259-121-01	SCREW, TR	
* 53	3-703-571-11	BUSHING (S) (4516), CORD (E)		* 63	4-880-403-11	HEAT SINK	
$\triangle$ 54	1-559-583-21	CORD, POWER (US, CND)		* 64	4-942-204-01	PLATE, GROUND	
$\triangle$ 54	1-696-027-11	CORD, POWER (E)		* 65	1-533-213-31	HOLDER, FUSE	
* 55	3-919-387-11	PANEL, BACK (US, CND)		* 66	3-309-144-21	HEAT SINK	
* 55	3-919-387-21	PANEL, BACK (E)		$\triangle$ S901	1-692-155-11	SELECTOR, POWER VOLTAGE (VOLTAGE SELECTOR) (E)	
56	3-704-515-01	SCREW (BV/RING)		$\triangle$ F701	1-532-285-00	FUSE, TIME-LAG (T1.25A 250V) (E)	
57	4-970-123-01	FOOT (F50180S)		$\triangle$ F701	1-532-741-11	FUSE, GLASS TUBE (1.25A 125V) (US, CND)	
58	4-970-124-01	CUSHION (F50180S)		$\triangle$ T001	1-427-832-11	TRANSFORMER, POWER (US, CND)	
* 59	A-2007-396-A	SYSTEM CONTROL BOARD, COMPLETE (E)		$\triangle$ T001	1-427-833-11	TRANSFORMER, POWER (E)	
* 59	A-2007-398-A	SYSTEM CONTROL BOARD, COMPLETE (US, CND)					
* 60	A-2007-395-A	AUDIO BOARD, COMPLETE (E)					

6-3. MECHANISM SECTION-1 (TCM-200D15)

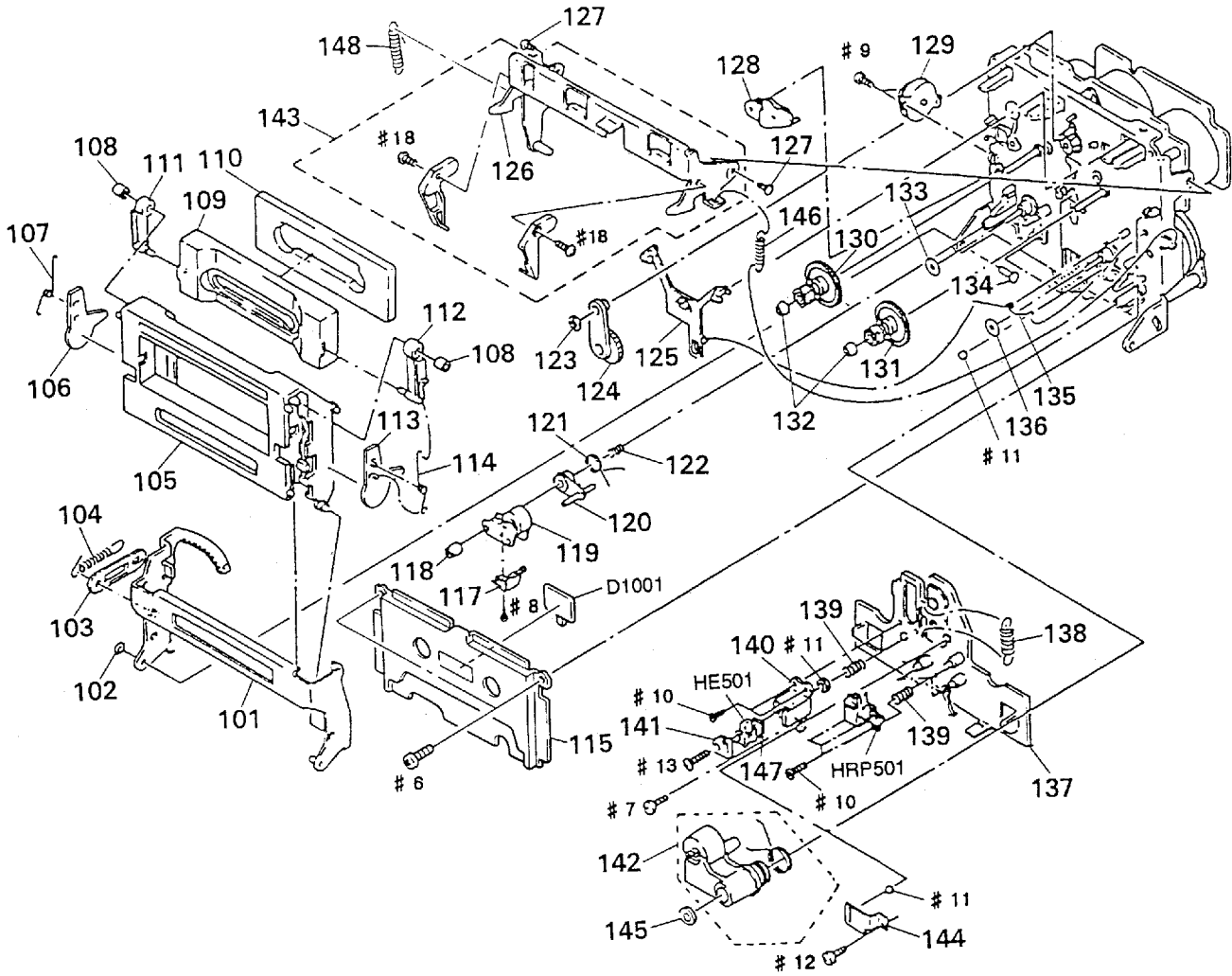

Ref. No.	Part No.	Description
101	X-3362-671-1	HOLDER (BG) ASSY, CASSETTE
102	3-558-708-21	WASHER, STOPPER
* 103	3-356-717-01	LEVER (JOINT)
104	3-356-626-01	SPRING, TENSION
105	X-3369-639-1	HOLDER (D15) ASSY, CASSETTE
106	3-920-319-01	LEVER (L-T)
107	3-920-363-01	SPRING (L), TORSION
108	3-356-946-01	BUSHING
109	3-356-928-01	PLATE (A), ORNAMENTAL
* 110	3-356-929-01	ABSORBENT, VIBRATION
111	3-356-933-01	LEVER (LB)
112	3-356-931-01	LEVER (RB)
113	3-920-320-01	LEVER (R-T)
114	3-920-364-01	SPRING (R), TORSION
115	X-3356-613-1	PLATE ASSY, ORNAMENTAL
117	3-920-576-01	GUIDE (SL), TAPE
118	3-356-652-01	NUT (PINCH LEVER S)
119	X-3356-621-1	LEVER (PINCH LEVER S) ASSY
120	3-356-660-01	LEVER (PS)
121	3-356-661-01	SPRING (PINCH LEVER S), TORSION
122	3-356-657-01	SPRING (PS), COMPRESSION
123	3-669-465-11	WASHER (1.5), STOPPER
124	X-3356-641-1	LEVER (FR2) ASSY
125	3-356-614-01	SLIDER (BRAKE)
* 126	X-3356-608-1	LEVER (LIFTER) ASSY

Remark	Ref. No.	Part No.	Description	Remark
	127	3-356-601-11	SCREW, STEP	
	128	X-3356-623-1	LEVER (BT) ASSY	
	129	3-319-224-41	DAMPER, SMALL	
	130	X-3356-629-1	GEAR (S) ASSY	
	131	X-3356-627-1	GEAR (T) ASSY	
	132	3-362-308-01	CAP (REEL)	
	133	3-332-763-01	RING, OIL RESERVOIR	
	134	3-356-710-01	SHAFT (LEFT) (CASSETTE HOLDER)	
	135	3-356-619-01	SPRING (B), TORSION	
	136	3-920-322-01	WASHER (FELT RING T)	
	* 137	X-3362-199-1	SLIDER (HEAD CHASSIS D) ASSY	
	138	3-356-658-01	SPRING (LIMITER H), TENSION	
	139	3-564-121-00	SPRING, COMPRESSION	
	* 140	3-576-977-00	BRACKET, E. HEAD	
	141	3-318-433-01	SPRING	
	142	X-3367-095-1	LEVER (PINCH LEVER DT) ASSY	
	* 143	X-3369-638-1	LEVER (LIFTER) COMPLETE ASSY	
	144	3-356-656-01	SPRING (HEAD PC BOARD), LEAF	
	145	3-669-596-01	WASHER (2.3), STOPPER	
	146	3-920-366-01	SPRING (LIFTER R), TENSION	
	* 147	1-608-268-00	ERASE HEAD BOARD	
	148	3-920-365-01	SPRING (LIFTER L), TENSION	
	D1001	8-719-980-85	DIODE S1F325C	
	HE501	1-543-836-11	HEAD, MAGNETIC (ERASE)	
	HRP501	1-543-684-21	HEAD, MAGNETIC (RECORD/PLAYBACK)	

6-4. MECHANISM SECTION-2 (TCM-200D15)

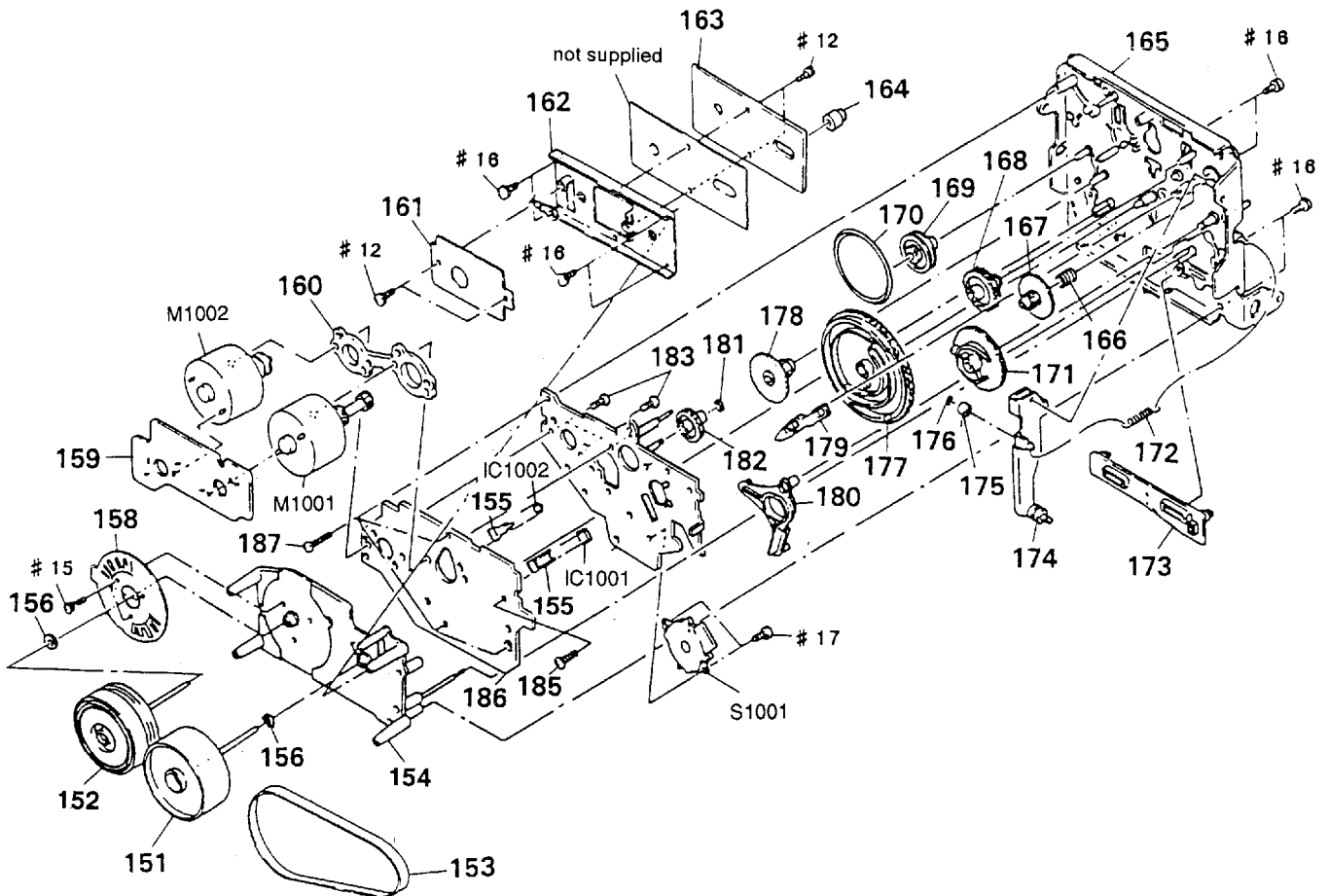

Ref. No.	Part No.	Description	Remark	Ref. No.	Part No.	Description	Remark
151	X-3369-635-1	FLYWHEEL (DS 2.5) ASSY		173	3-356-653-01	SLIDER (PAUSE)	
152	X-3369-634-1	FLYWHEEL (DT 2.8) ASSY		* 174	X-3356-606-1	LEVER (LOADING) ASSY	
153	3-364-600-01	BELT (CAPSTAN)		175	3-356-630-01	ROLLER (LOADING)	
* 154	X-3369-637-1	DECK (D 2.8) ASSY		176	3-558-708-11	WASHER, STOPPER	
155	3-356-631-01	HOLDER (SENSOR)		177	3-356-654-01	GEAR (MODE CAM C)	
156	3-356-705-51	WASHER (CAPSTAN)		178	3-356-606-01	GEAR (MODE)	
158	1-632-779-11	FG BOARD		179	3-356-617-01	LEVER (SELECTION)	
* 159	1-632-741-11	REEL MOTOR BOARD		180	3-356-613-01	LEVER (MODE)	
* 160	3-356-628-01	SPACER (MOTOR)		181	3-669-465-01	WASHER (1.5), STOPPER	
* 161	1-632-746-11	COMPARATOR BOARD		182	3-356-702-01	GEAR (COMMUNICATION B)	
* 162	X-3362-282-1	BRACKET (THRUST RETAINER) ASSY		183	3-363-804-01	SCREW (+P 2.6X6.5)	
* 163	A-2006-380-A	CAPSTAN C.O.C BOARD, COMPLETE		* 184	X-3356-616-1	BRACKET (MOTOR D) ASSY	
164	3-364-135-01	RETAINER (S), THRUST		185	3-356-707-01	SCREW (+PTPHW 2X25)	
165	X-3356-622-1	CHASSIS (C) ASSY, MECHANICAL		* 186	1-632-740-11	MD BOARD	
166	3-356-605-01	SPRING, COMPRESSION		187	3-355-801-01	SCREW (BTP 2X18)	
167	3-356-609-01	GEAR (LOADING)		IC1001	8-749-920-97	IC GP2S22B	
168	3-356-703-01	GEAR (COMMUNICATION C)		IC1002	8-749-920-97	IC GP2S22B	
169	3-356-607-01	PULLEY (MODE)		M1001	X-3356-638-1	MOTOR (REEL R) ASSY	
170	3-356-603-01	BELT (MODE)		M1002	X-3356-604-1	MOTOR (ASSIST) ASSY	
171	3-356-616-01	GEAR (LOADING CAM)		S1001	1-466-238-11	ENCODER, ROTARY	
172	3-356-624-01	SPRING, TENSION					

# AUDIO

## SECTION 7 ELECTRICAL PARTS LIST

Consisting the following section in the audio (AUDIO (A)/(B)/(C)/(D), DOLBY S)

### NOTE:

The components identified by mark  $\Delta$  or dotted line with mark  $\Delta$  are critical for safety. Replace only with part number specified.

Les composants identifiés par une marque  $\Delta$  sont critiques pour la sécurité. Ne les remplacer que par une pièce portant le numéro spécifié.

When indicating parts by reference number, please include the board name.

- Due to standardization, replacements in the parts list may be different from the parts specified in the diagrams or the components used on the set.
- Items marked "\*" are not stocked since they are seldom required for routine service. Some delay should be anticipated when ordering these items.
- RESISTORS  
All resistors are in ohms  
METAL: Metal-film resistor  
METAL OXIDE: Metal Oxide-film resistor  
F: nonflammable

- SEMICONDUCTORS  
In each case, u:  $\mu$ , for example:  
uA...:  $\mu$ A..., uPA...:  $\mu$ PA..., uPB...:  $\mu$ PB...,  
uPC...:  $\mu$ PC..., uPD...:  $\mu$ PD...
- CAPACITORS  
uF:  $\mu$ F
- COILS  
uH:  $\mu$ H
- Abbreviation  
CND: Canadian model

Ref.No.	Part No.	Description	Remark	Ref.No.	Part No.	Description	Remark
*	A-2007-395-A	AUDIO BOARD, COMPLETE (E) *****		C32	1-104-563-11	FILM CHIP	0.1uF 5% 16V
*	A-2007-397-A	AUDIO BOARD, COMPLETE (US, CND) ***** (Including AUDIO (A)/(B)/(C)/(D), DOLBY S BOARD)		C33	1-163-024-00	CERAMIC CHIP	0.018uF 10% 50V
*	1-537-473-11	TERMINAL (LEAD PIN)		C34	1-137-306-11	FILM CHIP	0.1uF 5% 16V
*	2-259-121-01	SCREW, TR		C35	1-163-012-00	CERAMIC CHIP	0.0018uF 10% 50V
*	4-942-204-01	PLATE, GROUND		C36	1-165-319-11	CERAMIC CHIP	0.1uF 50V
		< CAPACITOR >		C37	1-164-222-11	CERAMIC CHIP	0.22uF 25V
C1	1-164-222-11	CERAMIC CHIP	0.22uF 25V	C38	1-163-989-11	CERAMIC CHIP	0.033uF 10% 25V
C2	1-135-177-21	TANTALUM CHIP	1uF 20% 20V	C39	1-104-555-11	FILM CHIP	0.022uF 5% 16V
C3	1-137-301-11	FILM CHIP	0.039uF 5% 16V	C40	1-137-306-11	FILM CHIP	0.1uF 5% 16V
C4	1-163-007-11	CERAMIC CHIP	680PF 10% 50V	C101	1-130-893-00	FILM	0.027uF 5% 100V
C5	1-163-009-11	CERAMIC CHIP	0.001uF 10% 50V	C102	1-124-916-11	ELECT	22uF 20% 63V
C6	1-164-717-11	CERAMIC CHIP	0.0082uF 5% 50V	C103	1-124-916-11	ELECT	22uF 20% 63V
C7	1-164-222-11	CERAMIC CHIP	0.22uF 25V	C104	1-130-893-00	FILM	0.027uF 5% 100V
C8	1-104-562-11	FILM CHIP	0.082uF 5% 16V	C105	1-136-253-11	FILM	0.0018uF 5% 100V
C9	1-104-553-11	FILM CHIP	0.015uF 5% 16V	C106	1-107-161-00	MICA	39PF 5% 500V
C10	1-165-319-11	CERAMIC CHIP	0.1uF 50V	C107	1-136-253-11	FILM	0.0018uF 5% 100V
C11	1-135-145-11	TANTALUM CHIP	0.47uF 10% 35V	C108	1-130-475-00	MYLAR	0.0022uF 5% 50V
C12	1-164-222-11	CERAMIC CHIP	0.22uF 25V	C109	1-130-475-00	MYLAR	0.0022uF 5% 50V
C13	1-165-319-11	CERAMIC CHIP	0.1uF 50V	C110	1-130-478-00	MYLAR	0.0039uF 5% 50V
C14	1-162-568-11	CERAMIC CHIP	0.33uF 10% 16V	C111	1-136-173-00	FILM	0.47uF 5% 50V
C15	1-104-562-11	FILM CHIP	0.082uF 5% 16V	C112	1-136-167-00	FILM	0.15uF 5% 50V
C16	1-135-145-11	TANTALUM CHIP	0.47uF 10% 35V	C113	1-136-155-00	FILM	0.015uF 5% 50V
C17	1-165-319-11	CERAMIC CHIP	0.1uF 50V	C114	1-124-903-11	ELECT	1uF 20% 50V
C18	1-164-222-11	CERAMIC CHIP	0.22uF 25V	C115	1-136-169-00	FILM	0.22uF 5% 50V
C19	1-163-035-00	CERAMIC CHIP	0.047uF 50V	C116	1-136-163-00	FILM	0.068uF 5% 50V
C20	1-104-553-11	FILM CHIP	0.015uF 5% 16V	C117	1-136-162-00	FILM	0.056uF 5% 50V
C21	1-164-717-11	CERAMIC CHIP	0.0082uF 5% 50V	C118	1-124-903-11	ELECT	1uF 20% 50V
C22	1-163-009-11	CERAMIC CHIP	0.001uF 10% 50V	C119	1-130-480-00	MYLAR	0.0056uF 5% 50V
C23	1-164-161-11	CERAMIC CHIP	0.0022uF 10% 100V	C120	1-136-153-00	FILM	0.01uF 5% 50V
C24	1-163-005-11	CERAMIC CHIP	470PF 10% 50V	C121	1-124-916-11	ELECT	22uF 20% 63V
C25	1-163-012-00	CERAMIC CHIP	0.0018uF 10% 50V	C122	1-124-916-11	ELECT	22uF 20% 63V
C26	1-137-301-11	FILM CHIP	0.039uF 5% 16V	C123	1-124-916-11	ELECT	22uF 20% 63V
C27	1-163-012-00	CERAMIC CHIP	0.0018uF 10% 50V	C124	1-126-059-11	ELECT	10uF 20% 50V
C28	1-163-012-00	CERAMIC CHIP	0.0018uF 10% 50V	C125	1-124-916-11	ELECT	22uF 20% 63V
C29	1-137-306-11	FILM CHIP	0.1uF 5% 16V	C126	1-124-916-11	ELECT	22uF 20% 63V
C30	1-135-145-11	TANTALUM CHIP	0.47uF 10% 35V	C127	1-124-916-11	ELECT	22uF 20% 63V
C31	1-104-555-11	FILM CHIP	0.022uF 5% 16V	C132	1-126-059-11	ELECT	10uF 20% 50V
				C133	1-124-927-11	ELECT	4.7uF 20% 100V
				C134	1-124-927-11	ELECT	4.7uF 20% 100V
				C135	1-124-927-11	ELECT	4.7uF 20% 100V
				C137	1-130-475-00	MYLAR	0.0022uF 5% 50V
				C138	1-130-475-00	MYLAR	0.0022uF 5% 50V

# AUDIO

Ref. No.	Part No.	Description			Remark	Ref. No.	Part No.	Description			Remark
C139	1-130-478-00	MYLAR	0.0039uF	5%	50V	C214	1-124-903-11	ELECT	1uF	20%	50V
C140	1-136-173-00	FILM	0.47uF	5%	50V	C215	1-136-169-00	FILM	0.22uF	5%	50V
C141	1-136-167-00	FILM	0.15uF	5%	50V	C216	1-136-163-00	FILM	0.068uF	5%	50V
C142	1-136-155-00	FILM	0.015uF	5%	50V	C217	1-136-162-00	FILM	0.056uF	5%	50V
C143	1-124-903-11	ELECT	1uF	20%	50V	C218	1-124-903-11	ELECT	1uF	20%	50V
C144	1-136-169-00	FILM	0.22uF	5%	50V	C219	1-130-480-00	MYLAR	0.0056uF	5%	50V
C145	1-136-163-00	FILM	0.068uF	5%	50V	C220	1-136-153-00	FILM	0.01uF	5%	50V
C146	1-136-162-00	FILM	0.056uF	5%	50V	C221	1-124-916-11	ELECT	22uF	20%	63V
C147	1-124-903-11	ELECT	1uF	20%	50V	C222	1-124-916-11	ELECT	22uF	20%	63V
C148	1-130-480-00	MYLAR	0.0056uF	5%	50V	C223	1-124-916-11	ELECT	22uF	20%	63V
C149	1-136-153-00	FILM	0.01uF	5%	50V	C224	1-126-059-11	ELECT	10uF	20%	50V
C150	1-126-059-11	ELECT	10uF	20%	50V	C225	1-124-916-11	ELECT	22uF	20%	63V
C151	1-126-059-11	ELECT	10uF	20%	50V	C226	1-124-916-11	ELECT	22uF	20%	63V
C152	1-124-916-11	ELECT	22uF	20%	63V	C227	1-124-916-11	ELECT	22uF	20%	63V
C153	1-126-059-11	ELECT	10uF	20%	50V	C232	1-126-059-11	ELECT	10uF	20%	50V
C154	1-124-916-11	ELECT	22uF	20%	63V	C233	1-124-927-11	ELECT	4.7uF	20%	100V
C155	1-124-916-11	ELECT	22uF	20%	63V	C234	1-124-927-11	ELECT	4.7uF	20%	100V
C158	1-106-347-00	MYLAR	1500PF	5%	200V	C235	1-124-927-11	ELECT	4.7uF	20%	100V
C159	1-126-059-11	ELECT	10uF	20%	50V	C237	1-130-475-00	MYLAR	0.0022uF	5%	50V
C160	1-130-493-00	MYLAR	0.068uF	5%	50V	C238	1-130-475-00	MYLAR	0.0022uF	5%	50V
C161	1-130-485-00	MYLAR	0.015uF	5%	50V	C239	1-130-478-00	MYLAR	0.0039uF	5%	50V
C162	1-130-489-00	MYLAR	0.033uF	5%	50V	C240	1-136-173-00	FILM	0.47uF	5%	50V
C163	1-130-485-00	MYLAR	0.015uF	5%	50V	C241	1-136-167-00	FILM	0.15uF	5%	50V
C164	1-130-490-11	MYLAR	0.039uF	5%	50V	C242	1-136-155-00	FILM	0.015uF	5%	50V
C165	1-130-486-00	MYLAR	0.018uF	10%	50V	C243	1-124-903-11	ELECT	1uF	20%	50V
C166	1-124-916-11	ELECT	22uF	20%	63V	C244	1-136-169-00	FILM	0.22uF	5%	50V
C167	1-136-252-00	FILM	0.0015uF	5%	100V	C245	1-136-163-00	FILM	0.068uF	5%	50V
C168	1-107-597-11	MICA	22PF	5%	500V	C246	1-136-162-00	FILM	0.056uF	5%	50V
C169	1-136-157-00	FILM	0.022uF	5%	50V	C247	1-124-903-11	ELECT	1uF	20%	50V
C170	1-136-161-00	FILM	0.047uF	5%	50V	C248	1-130-480-00	MYLAR	0.0056uF	5%	50V
C171	1-110-341-11	MYLAR	330PF	5%	50V	C249	1-136-153-00	FILM	0.01uF	5%	50V
C172	1-136-803-11	FILM	560PF	5%	630V	C250	1-126-059-11	ELECT	10uF	20%	50V
C173	1-107-611-11	MICA	100PF	5%	500V	C251	1-126-059-11	ELECT	10uF	20%	50V
C174	1-136-153-00	FILM	0.01uF	5%	50V	C252	1-124-916-11	ELECT	22uF	20%	63V
C176	1-124-925-11	ELECT	2.2uF	20%	100V	C253	1-126-059-11	ELECT	10uF	20%	50V
C178	1-126-059-11	ELECT	10uF	20%	50V	C254	1-124-916-11	ELECT	22uF	20%	63V
C180	1-124-916-11	ELECT	22uF	20%	63V	C255	1-124-916-11	ELECT	22uF	20%	63V
C201	1-130-893-00	FILM	0.027uF	5%	100V	C258	1-106-347-00	MYLAR	1500PF	5%	200V
C202	1-124-916-11	ELECT	22uF	20%	63V	C259	1-126-059-11	ELECT	10uF	20%	50V
C203	1-124-916-11	ELECT	22uF	20%	63V	C260	1-130-493-00	MYLAR	0.068uF	5%	50V
C204	1-130-893-00	FILM	0.027uF	5%	100V	C261	1-130-485-00	MYLAR	0.015uF	5%	50V
C205	1-136-253-11	FILM	0.0018uF	5%	100V	C262	1-130-489-00	MYLAR	0.033uF	5%	50V
C206	1-107-161-00	MICA	39PF	5%	500V	C263	1-130-485-00	MYLAR	0.015uF	5%	50V
C207	1-136-253-11	FILM	0.0018uF	5%	100V	C264	1-130-490-11	MYLAR	0.039uF	5%	50V
C208	1-130-475-00	MYLAR	0.0022uF	5%	50V	C265	1-130-486-00	MYLAR	0.018uF	10%	50V
C209	1-130-475-00	MYLAR	0.0022uF	5%	50V	C266	1-124-916-11	ELECT	22uF	20%	63V
C210	1-130-478-00	MYLAR	0.0039uF	5%	50V	C267	1-136-252-00	FILM	0.0015uF	5%	100V
C211	1-136-173-00	FILM	0.47uF	5%	50V	C268	1-107-597-11	MICA	22PF	5%	500V
C212	1-136-167-00	FILM	0.15uF	5%	50V	C269	1-136-157-00	FILM	0.022uF	5%	50V
C213	1-136-155-00	FILM	0.015uF	5%	50V	C270	1-136-161-00	FILM	0.047uF	5%	50V



# AUDIO

Ref. No.	Part No.	Description			Remark	Ref. No.	Part No.	Description			Remark
C271	1-110-341-11	MYLAR	330PF	5%	50V	C599	1-162-302-11	CERAMIC	0.0022uF	20%	16V
C272	1-136-803-11	FILM	560PF	5%	630V			< CONNECTOR >			
C273	1-107-611-11	MICA	100PF	5%	500V	CN501	1-764-817-11	CONNECTOR, BOARD TO BOARD	8P		
C274	1-136-153-00	FILM	0.01uF	5%	50V	* CN502	1-560-062-00	PIN, CONNECTOR	4P		
C276	1-124-925-11	ELECT	2.2uF	20%	100V	CN503	1-691-767-11	PLUG (MICRO CONNECTOR)	5P		
C278	1-126-059-11	ELECT	10uF	20%	50V	* CN504	1-564-519-11	PLUG, CONNECTOR	4P		
C280	1-124-916-11	ELECT	22uF	20%	63V	CN505	1-564-523-11	PLUG, CONNECTOR	8P		
C501	1-126-066-11	ELECT	470uF	20%	63V	CN506	1-691-765-11	PLUG (MICRO CONNECTOR)	3P		
C502	1-126-066-11	ELECT	470uF	20%	63V	CN507	1-691-770-11	PLUG (MICRO CONNECTOR)	8P		
C503	1-107-601-11	MICA	33PF	5%	500V	* CN508	1-560-062-00	PIN, CONNECTOR	4P		
C504	1-107-601-11	MICA	33PF	5%	500V	* CN509	1-560-061-00	PIN, CONNECTOR	3P		
C505	1-124-122-11	ELECT	100uF	20%	50V	* CN510	1-568-937-21	PIN, CONNECTOR	10P		
C506	1-136-153-00	FILM	0.01uF	5%	50V	* CN511	1-568-935-11	PIN, CONNECTOR	8P		
C507	1-136-153-00	FILM	0.01uF	5%	50V	CN512	1-506-468-11	PIN, CONNECTOR	3P		
C508	1-124-922-11	ELECT	1000uF	20%	63V	CN513	1-506-468-11	PIN, CONNECTOR	3P		
C509	1-124-922-11	ELECT	1000uF	20%	63V	CN705	1-691-765-11	PLUG (MICRO CONNECTOR)	3P		
C510	1-126-059-11	ELECT	10uF	20%	50V	CNP505	1-691-768-11	PLUG (MICRO CONNECTOR)	6P		
C511	1-126-059-11	ELECT	10uF	20%	50V			< FILTER >			
C513	1-126-059-11	ELECT	10uF	20%	50V	CP103	1-236-087-11	FILTER, LOW PASS			
C514	1-126-059-11	ELECT	10uF	20%	50V	CP203	1-236-087-11	FILTER, LOW PASS			
C515	1-164-159-11	CERAMIC	0.1uF		50V			< DIODE >			
C516	1-124-902-00	ELECT	0.47uF	20%	50V	D101	8-719-987-63	DIODE	1N4148M		
C518	1-126-059-11	ELECT	10uF	20%	50V	D102	8-719-987-63	DIODE	1N4148M		
C519	1-126-059-11	ELECT	10uF	20%	50V	D104	8-719-987-63	DIODE	1N4148M		
C522	1-124-927-11	ELECT	4.7uF	20%	100V	D108	8-719-987-63	DIODE	1N4148M		
C523	1-124-927-11	ELECT	4.7uF	20%	100V	D109	8-719-987-63	DIODE	1N4148M		
C526	1-126-059-11	ELECT	10uF	20%	50V	D201	8-719-987-63	DIODE	1N4148M		
C527	1-126-059-11	ELECT	10uF	20%	50V	D202	8-719-987-63	DIODE	1N4148M		
C529	1-124-907-11	ELECT	10uF	20%	50V	D204	8-719-987-63	DIODE	1N4148M		
C530	1-126-059-11	ELECT	10uF	20%	50V	D208	8-719-987-63	DIODE	1N4148M		
C531	1-126-059-11	ELECT	10uF	20%	50V	D209	8-719-987-63	DIODE	1N4148M		
C532	1-124-925-11	ELECT	2.2uF	20%	100V	D501	8-719-933-41	DIODE	HZS6C3L		
C533	1-126-059-11	ELECT	10uF	20%	50V	D504	8-719-987-63	DIODE	1N4148M		
C534	1-124-477-11	ELECT	47uF	20%	25V	D507	8-719-987-63	DIODE	1N4148M		
C535	1-136-161-00	FILM	0.047uF	5%	50V	D508	8-719-000-81	DIODE	UZL-7L3		
C536	1-124-907-11	ELECT	10uF	20%	50V	D509	8-719-000-81	DIODE	UZL-7L3		
C537	1-124-925-11	ELECT	2.2uF	20%	100V	D516	8-719-000-81	DIODE	UZL-7L3		
C538	1-162-282-31	CERAMIC	100PF	10%	50V	D517	8-719-000-81	DIODE	UZL-7L3		
C539	1-136-228-11	FILM	0.0012uF	5%	100V	D520	8-719-987-63	DIODE	1N4148M		
C540	1-136-228-11	FILM	0.0012uF	5%	100V	D521	8-719-987-63	DIODE	1N4148M		
C541	1-136-233-11	FILM	0.0047uF	5%	100V	D522	8-719-987-63	DIODE	1N4148M		
C542	1-124-907-11	ELECT	10uF	20%	50V	D523	8-719-987-63	DIODE	1N4148M		
C543	1-136-559-11	FILM	0.0047uF	5%	630V	D524	8-719-987-63	DIODE	1N4148M		
C544	1-107-584-11	CERAMIC	4PF	0.25PF	500V			< IC >			
C545	1-124-907-11	ELECT	10uF	20%	50V	IC1	8-752-056-51	IC	CXA1417Q		
C548	1-126-059-11	ELECT	10uF	20%	50V	IC2	8-759-711-85	IC	NJM4580E-D		
C549	1-126-059-11	ELECT	10uF	20%	50V						
C585	1-124-902-00	ELECT	0.47uF	20%	50V						
C586	1-164-159-11	CERAMIC	0.1uF		50V						
C587	1-164-159-11	CERAMIC	0.1uF		50V						

# AUDIO

Ref. No.	Part No.	Description	Remark	Ref. No.	Part No.	Description	Remark
IC501	8-759-602-01	IC M5220P		Q206	8-729-203-06	TRANSISTOR 2SK30A-GR2	
IC502	8-752-018-80	IC CX20188		Q207	8-729-922-37	TRANSISTOR 2SD2144S-UVW	
IC505	8-759-711-35	IC NJM4580D		Q209	8-729-922-37	TRANSISTOR 2SD2144S-UVW	
IC506	8-759-634-51	IC M5218AP		Q210	8-729-203-06	TRANSISTOR 2SK30A-GR2	
IC510	8-759-711-35	IC NJM4580D		Q211	8-729-203-06	TRANSISTOR 2SK30A-GR2	
IC511	8-752-018-80	IC CX20188		Q212	8-729-922-37	TRANSISTOR 2SD2144S-UVW	
IC513	8-759-711-35	IC NJM4580D		Q213	8-729-922-37	TRANSISTOR 2SD2144S-UVW	
IC514	8-759-106-56	IC $\mu$ PC1297CA		Q214	8-729-922-37	TRANSISTOR 2SD2144S-UVW	
IC516	8-759-634-51	IC M5218AP		Q215	8-729-922-37	TRANSISTOR 2SD2144S-UVW	
IC517	8-759-634-51	IC M5218AP		Q216	8-729-922-37	TRANSISTOR 2SD2144S-UVW	
< JACK >				Q217	8-729-900-80	TRANSISTOR DTC114ES	
J501	1-507-796-71	JACK (HEADPHONES)		Q231	8-729-922-37	TRANSISTOR 2SD2144S-UVW	
* J502	1-573-142-31	JACK, PIN 4P (LINE IN/OUT)		Q501	8-729-107-53	TRANSISTOR 2SC2275A	
< COIL >				Q502	8-729-141-10	TRANSISTOR 2SA985A-QP	
L101	1-408-927-11	INDUCTOR 18mH		Q503	8-729-224-62	TRANSISTOR 2SK246-GR	
L102	1-408-920-00	INDUCTOR 4.7mH		Q504	8-729-224-62	TRANSISTOR 2SK246-GR	
L103	1-408-918-11	INDUCTOR 3.3mH		Q505	8-729-366-62	TRANSISTOR 2SD666-C	
L104	1-408-916-11	INDUCTOR 2.2mH		Q506	8-729-364-62	TRANSISTOR 2SB646-C	
L105	1-408-929-00	INDUCTOR 27mH		Q507	8-729-366-62	TRANSISTOR 2SD666-C	
L106	1-410-769-31	INDUCTOR 3.3mH		Q508	8-729-364-62	TRANSISTOR 2SB646-C	
L201	1-408-927-11	INDUCTOR 18mH		Q509	8-729-922-37	TRANSISTOR 2SD2144S-UVW	
L202	1-408-920-00	INDUCTOR 4.7mH		Q512	8-729-620-05	TRANSISTOR 2SC2603-EF	
L203	1-408-918-11	INDUCTOR 3.3mH		Q513	8-729-119-76	TRANSISTOR 2SA1175-HFE	
L204	1-408-916-11	INDUCTOR 2.2mH		Q514	8-729-620-05	TRANSISTOR 2SC2603-EF	
L205	1-408-929-00	INDUCTOR 27mH		Q515	8-729-119-76	TRANSISTOR 2SA1175-HFE	
L206	1-410-769-31	INDUCTOR 3.3mH		Q516	8-729-900-89	TRANSISTOR DTC144ES	
< TRANSISTOR >				Q517	8-729-900-89	TRANSISTOR DTC144ES	
Q101	8-729-922-37	TRANSISTOR 2SD2144S-UVW		Q518	8-729-900-89	TRANSISTOR DTC144ES	
Q102	8-729-922-37	TRANSISTOR 2SD2144S-UVW		Q521	8-729-900-61	TRANSISTOR DTA114ES	
Q103	8-729-203-06	TRANSISTOR 2SK30A-GR2		Q522	8-729-900-80	TRANSISTOR DTC114ES	
Q104	8-729-203-06	TRANSISTOR 2SK30A-GR2		Q523	8-729-900-80	TRANSISTOR DTC114ES	
Q106	8-729-203-06	TRANSISTOR 2SK30A-GR2		Q524	8-729-900-80	TRANSISTOR DTC114ES	
Q107	8-729-922-37	TRANSISTOR 2SD2144S-UVW		Q525	8-729-900-80	TRANSISTOR DTC114ES	
Q109	8-729-922-37	TRANSISTOR 2SD2144S-UVW		Q526	8-729-119-78	TRANSISTOR 2SC2785-HFE	
Q110	8-729-203-06	TRANSISTOR 2SK30A-GR2		Q527	8-729-194-57	TRANSISTOR 2SC945-P	
Q111	8-729-203-06	TRANSISTOR 2SK30A-GR2		Q528	8-729-194-57	TRANSISTOR 2SC945-P	
Q112	8-729-922-37	TRANSISTOR 2SD2144S-UVW		Q529	8-729-900-65	TRANSISTOR DTA144ES	
Q113	8-729-922-37	TRANSISTOR 2SD2144S-UVW		Q530	8-729-900-80	TRANSISTOR DTC114ES	
Q114	8-729-922-37	TRANSISTOR 2SD2144S-UVW		Q531	8-729-900-61	TRANSISTOR DTA114ES	
Q115	8-729-922-37	TRANSISTOR 2SD2144S-UVW		Q532	8-729-900-80	TRANSISTOR DTC114ES	
Q116	8-729-922-37	TRANSISTOR 2SD2144S-UVW		Q533	8-729-900-80	TRANSISTOR DTC114ES	
Q117	8-729-900-80	TRANSISTOR DTC114ES		< RESISTOR >			
Q131	8-729-922-37	TRANSISTOR 2SD2144S-UVW		R1	1-216-615-11	METAL CHIP 33 0.5% 1/10W	
Q201	8-729-922-37	TRANSISTOR 2SD2144S-UVW		R2	1-208-806-11	METAL GLAZE 10K 2% 1/10W	
Q202	8-729-922-37	TRANSISTOR 2SD2144S-UVW		R3	1-208-812-11	METAL GLAZE 18K 2% 1/10W	
Q203	8-729-203-06	TRANSISTOR 2SK30A-GR2		R4	1-208-556-41	METAL GLAZE 820K 2% 1/10W	
Q204	8-729-203-06	TRANSISTOR 2SK30A-GR2		R5	1-208-799-11	METAL GLAZE 5.1K 2% 1/10W	
				R6	1-208-787-11	METAL GLAZE 1.6K 2% 1/10W	
				R7	1-216-657-11	METAL CHIP 1.8K 0.5% 1/10W	

# AUDIO

Ref. No.	Part No.	Description	Remark			Ref. No.	Part No.	Description	Remark		
R8	1-216-667-11	METAL CHIP	4.7K	0.5%	1/10W	R110	1-247-152-00	CARBON	8.2K	5%	1/4W
R9	1-208-791-11	METAL GLAZE	2.4K	2%	1/10W	R111	1-247-710-11	CARBON	560	5%	1/4W F
R10	1-208-440-41	METAL GLAZE	1.3K	2%	1/10W	R112	1-247-725-11	CARBON	10K	5%	1/4W F
R11	1-216-615-11	METAL CHIP	33	0.5%	1/10W	R113	1-249-932-11	CARBON	2.4K	1%	1/4W
R12	1-216-619-11	METAL CHIP	47	0.5%	1/10W	R114	1-249-938-91	CARBON	4.3K	1%	1/4W
R13	1-208-784-11	METAL GLAZE	1.2K	2%	1/10W	R115	1-259-500-11	CARBON	1M	5%	1/6W
R14	1-216-667-11	METAL CHIP	4.7K	0.5%	1/10W	R116	1-247-710-11	CARBON	560	5%	1/4W F
R15	1-208-791-11	METAL GLAZE	2.4K	2%	1/10W	R117	1-249-462-11	CARBON	22K	5%	1/4W
R16	1-216-615-11	METAL CHIP	33	0.5%	1/10W	R118	1-259-449-11	CARBON	7.5K	5%	1/6W
R17	1-216-619-11	METAL CHIP	47	0.5%	1/10W	R119	1-259-424-11	CARBON	680	5%	1/6W
R18	1-216-657-11	METAL CHIP	1.8K	0.5%	1/10W	R120	1-259-451-11	CARBON	9.1K	5%	1/6W
R19	1-208-787-11	METAL GLAZE	1.6K	2%	1/10W	R121	1-249-425-11	CARBON	4.7K	5%	1/4W F
R20	1-208-799-11	METAL GLAZE	5.1K	2%	1/10W	R122	1-249-973-11	CARBON	120K	1%	1/4W
R21	1-208-556-41	METAL CHIP	820K	2%	1/10W	R123	1-249-951-11	CARBON	15K	1%	1/4W
R22	1-216-655-11	METAL CHIP	1.5K	0.5%	1/10W	R124	1-249-949-11	CARBON	12K	1%	1/4W
R23	1-216-678-11	METAL CHIP	13K	0.5%	1/10W	R125	1-249-927-11	CARBON	1.5K	1%	1/4W
R24	1-216-673-11	METAL CHIP	8.2K	0.5%	1/10W	R128	1-249-465-11	CARBON	47K	5%	1/4W
R25	1-208-806-11	METAL GLAZE	10K	2%	1/10W	R129	1-247-716-11	CARBON	1.8K	5%	1/4W F
R26	1-216-676-11	METAL CHIP	11K	0.5%	1/10W	R130	1-249-425-11	CARBON	4.7K	5%	1/4W F
R27	1-208-799-11	METAL GLAZE	5.1K	2%	1/10W	R131	1-249-465-11	CARBON	47K	5%	1/4W
R28	1-216-695-11	METAL CHIP	68K	0.5%	1/10W	R132	1-247-725-11	CARBON	10K	5%	1/4W F
R29	1-208-799-11	METAL GLAZE	5.1K	2%	1/10W	R133	1-215-438-00	METAL	5.1K	1%	1/4W
R30	1-208-791-11	METAL GLAZE	2.4K	2%	1/10W	R134	1-249-465-11	CARBON	47K	5%	1/4W
R31	1-208-811-11	METAL GLAZE	16K	2%	1/10W	R135	1-247-725-11	CARBON	10K	5%	1/4W F
R32	1-216-685-11	METAL CHIP	27K	0.5%	1/10W	R136	1-249-465-11	CARBON	47K	5%	1/4W
R33	1-208-813-11	METAL GLAZE	20K	2%	1/10W	R137	1-247-700-11	CARBON	100	5%	1/4W F
R34	1-216-684-11	METAL CHIP	24K	0.5%	1/10W	R138	1-249-425-11	CARBON	4.7K	5%	1/4W F
R35	1-208-817-11	METAL GLAZE	30K	2%	1/10W	R139	1-247-713-11	CARBON	1K	5%	1/4W F
R36	1-208-817-11	METAL GLAZE	30K	2%	1/10W	R140	1-247-713-11	CARBON	1K	5%	1/4W F
R37	1-216-676-11	METAL CHIP	11K	0.5%	1/10W	R144	1-247-725-11	CARBON	10K	5%	1/4W F
R38	1-208-819-11	METAL GLAZE	36K	2%	1/10W	R145	1-247-718-11	CARBON	2.7K	5%	1/4W F
R39	1-208-799-11	METAL GLAZE	5.1K	2%	1/10W	R146	1-249-462-11	CARBON	22K	5%	1/4W
R40	1-208-817-11	METAL GLAZE	30K	2%	1/10W	R147	1-247-704-11	CARBON	220	5%	1/4W F
R41	1-208-811-11	METAL GLAZE	16K	2%	1/10W	R148	1-247-700-11	CARBON	100	5%	1/4W F
R42	1-216-673-11	METAL CHIP	8.2K	0.5%	1/10W	R149	1-249-586-11	CARBON	27K	5%	1/4W
R43	1-216-676-11	METAL CHIP	11K	0.5%	1/10W	R150	1-249-469-11	CARBON	100K	5%	1/4W
R44	1-216-689-11	METAL CHIP	39K	0.5%	1/10W	R151	1-247-723-11	CARBON	6.8K	5%	1/4W F
R45	1-216-689-11	METAL CHIP	39K	0.5%	1/10W	R152	1-247-720-11	CARBON	3.9K	5%	1/4W F
R51	1-208-800-11	METAL GLAZE	5.6K	2%	1/10W	R153	1-247-152-00	CARBON	7.5K	5%	1/4W
R52	1-216-663-11	METAL CHIP	3.3K	0.5%	1/10W	R154	1-249-465-11	CARBON	47K	5%	1/4W
R55	1-208-789-11	METAL GLAZE	2K	2%	1/10W	R155	1-249-465-11	CARBON	47K	5%	1/4W
R101	1-249-466-11	CARBON	56K	5%	1/4W	R156	1-247-128-00	CARBON	750	5%	1/4W
R102	1-249-531-11	CARBON	130	5%	1/4W	R157	1-247-725-11	CARBON	10K	5%	1/4W F
R103	1-247-146-00	CARBON	4.3K	5%	1/4W	R158	1-249-932-11	CARBON	2.4K	1%	1/4W
R104	1-249-602-11	CARBON	120K	5%	1/4W	R159	1-249-938-91	CARBON	4.3K	1%	1/4W
R105	1-249-465-11	CARBON	47K	5%	1/4W	R160	1-259-500-11	CARBON	1M	5%	1/6W
R106	1-247-717-11	CARBON	2.2K	5%	1/4W F	R161	1-247-710-11	CARBON	560	5%	1/4W F
R107	1-247-138-00	CARBON	2K	5%	1/4W	R162	1-249-462-11	CARBON	22K	5%	1/4W
R108	1-249-429-11	CARBON	10K	5%	1/4W	R163	1-259-449-11	CARBON	7.5K	5%	1/6W
R109	1-247-717-11	CARBON	2.2K	5%	1/4W F	R164	1-259-424-11	CARBON	680	5%	1/6W

# AUDIO

Ref. No.	Part No.	Description	Remark	Ref. No.	Part No.	Description	Remark
R165	1-259-451-11	CARBON	9. 1K 5% 1/6W	R222	1-249-973-11	CARBON	120K 1% 1/4W
R166	1-249-469-11	CARBON	100K 5% 1/4W	R223	1-249-951-11	CARBON	15K 1% 1/4W
R167	1-249-425-11	CARBON	4. 7K 5% 1/4W F	R224	1-249-949-11	CARBON	12K 1% 1/4W
R168	1-249-955-11	CARBON	22K 1% 1/4W	R225	1-249-927-11	CARBON	1. 5K 1% 1/4W
R169	1-249-955-11	CARBON	22K 1% 1/4W	R228	1-249-465-11	CARBON	47K 5% 1/4W
R170	1-249-935-11	CARBON	3. 3K 1% 1/4W	R229	1-247-716-11	CARBON	1. 8K 5% 1/4W F
R171	1-249-935-11	CARBON	3. 3K 1% 1/4W	R230	1-249-425-11	CARBON	4. 7K 5% 1/4W F
R172	1-249-469-11	CARBON	100K 5% 1/4W	R231	1-249-465-11	CARBON	47K 5% 1/4W
R173	1-249-465-11	CARBON	47K 5% 1/4W	R232	1-247-725-11	CARBON	10K 5% 1/4W F
R179	1-247-719-11	CARBON	3. 3K 5% 1/4W F	R233	1-215-438-00	METAL	5. 1K 1% 1/4W
R180	1-247-723-11	CARBON	6. 8K 5% 1/4W F	R234	1-249-465-11	CARBON	47K 5% 1/4W
R181	1-249-421-11	CARBON	2. 2K 5% 1/4W F	R235	1-247-725-11	CARBON	10K 5% 1/4W F
R182	1-249-590-11	CARBON	39K 5% 1/4W	R236	1-249-465-11	CARBON	47K 5% 1/4W
R183	1-249-429-11	CARBON	10K 5% 1/4W	R237	1-247-700-11	CARBON	100 5% 1/4W F
R184	1-249-465-11	CARBON	47K 5% 1/4W	R238	1-249-425-11	CARBON	4. 7K 5% 1/4W F
R185	1-249-556-11	CARBON	1. 5K 5% 1/4W	R239	1-247-713-11	CARBON	1K 5% 1/4W F
R186	1-259-474-11	CARBON	82K 5% 1/6W	R240	1-247-713-11	CARBON	1K 5% 1/4W F
R187	1-249-962-11	CARBON	43K 1% 1/4W	R244	1-247-725-11	CARBON	10K 5% 1/4W F
R188	1-249-531-11	CARBON	130 5% 1/4W	R245	1-247-718-11	CARBON	2. 7K 5% 1/4W F
R190	1-247-701-11	CARBON	120 5% 1/4W F	R246	1-249-462-11	CARBON	22K 5% 1/4W
R191	1-249-462-11	CARBON	22K 5% 1/4W	R247	1-247-704-11	CARBON	220 5% 1/4W F
R192	1-247-721-11	CARBON	4. 7K 5% 1/4W F	R248	1-247-700-11	CARBON	100 5% 1/4W F
R193	1-247-700-11	CARBON	100 5% 1/4W F	R249	1-249-586-11	CARBON	27K 5% 1/4W
R194	1-247-152-00	CARBON	8. 2K 5% 1/4W	R250	1-249-469-11	CARBON	100K 5% 1/4W
R195	1-247-721-11	CARBON	4. 7K 5% 1/4W F	R251	1-247-723-11	CARBON	6. 8K 5% 1/4W F
R196	1-249-429-11	CARBON	10K 5% 1/4W	R252	1-247-720-11	CARBON	3. 9K 5% 1/4W F
R197	1-249-429-11	CARBON	10K 5% 1/4W	R253	1-247-152-00	CARBON	7. 5K 5% 1/4W
R198	1-249-429-11	CARBON	10K 5% 1/4W	R254	1-249-465-11	CARBON	47K 5% 1/4W
R199	1-247-718-11	CARBON	2. 7K 5% 1/4W F	R255	1-249-465-11	CARBON	47K 5% 1/4W
R201	1-249-466-11	CARBON	56K 5% 1/4W	R256	1-247-128-00	CARBON	750 5% 1/4W
R202	1-249-531-11	CARBON	130 5% 1/4W	R257	1-247-725-11	CARBON	10K 5% 1/4W F
R203	1-247-146-00	CARBON	4. 3K 5% 1/4W	R258	1-249-932-11	CARBON	2. 4K 1% 1/4W
R204	1-249-602-11	CARBON	120K 5% 1/4W	R259	1-249-938-91	CARBON	4. 3K 1% 1/4W
R205	1-249-455-11	CARBON	47K 5% 1/4W	R260	1-259-500-11	CARBON	1M 5% 1/6W
R206	1-247-717-11	CARBON	2. 2K 5% 1/4W F	R261	1-247-710-11	CARBON	560 5% 1/4W F
R207	1-247-138-00	CARBON	2K 5% 1/4W	R262	1-249-462-11	CARBON	22K 5% 1/4W
R208	1-249-429-11	CARBON	10K 5% 1/4W	R263	1-259-449-11	CARBON	7. 5K 5% 1/6W
R209	1-247-717-11	CARBON	2. 2K 5% 1/4W F	R264	1-259-424-11	CARBON	680 5% 1/6W
R210	1-247-152-00	CARBON	8. 2K 5% 1/4W	R265	1-259-451-11	CARBON	9. 1K 5% 1/6W
R211	1-247-710-11	CARBON	560 5% 1/4W F	R266	1-249-469-11	CARBON	100K 5% 1/4W
R212	1-247-725-11	CARBON	10K 5% 1/4W F	R267	1-249-425-11	CARBON	4. 7K 5% 1/4W F
R213	1-249-932-11	CARBON	2. 4K 1% 1/4W	R268	1-249-955-11	CARBON	22K 1% 1/4W
R214	1-249-938-91	CARBON	4. 3K 1% 1/4W	R269	1-249-955-11	CARBON	22K 1% 1/4W
R215	1-259-500-11	CARBON	1M 5% 1/6W	R270	1-249-935-11	CARBON	3. 3K 1% 1/4W
R216	1-247-710-11	CARBON	560 5% 1/4W F	R271	1-249-935-11	CARBON	3. 3K 1% 1/4W
R217	1-249-462-11	CARBON	22K 5% 1/4W	R272	1-249-469-11	CARBON	100K 5% 1/4W
R218	1-259-449-11	CARBON	7. 5K 5% 1/6W	R273	1-249-465-11	CARBON	47K 5% 1/4W
R219	1-259-424-11	CARBON	680 5% 1/6W	R279	1-247-719-11	CARBON	3. 3K 5% 1/4W F
R220	1-259-451-11	CARBON	9. 1K 5% 1/6W	R280	1-247-723-11	CARBON	6. 8K 5% 1/4W F
R221	1-249-425-11	CARBON	4. 7K 5% 1/4W F	R281	1-249-421-11	CARBON	2. 2K 5% 1/4W F

# AUDIO

Ref. No.	Part No.	Description	Remark	Ref. No.	Part No.	Description	Remark
R282	1-249-590-11	CARBON	39K 5% 1/4W	R519	1-247-885-00	CARBON	180K 5% 1/4W
R283	1-249-429-11	CARBON	10K 5% 1/4W	R520	1-249-433-11	CARBON	22K 5% 1/4W
R284	1-249-465-11	CARBON	47K 5% 1/4W	R521	1-249-413-11	CARBON	470 5% 1/4W F
R285	1-249-556-11	CARBON	1.5K 5% 1/4W	R522	1-249-413-11	CARBON	470 5% 1/4W F
R286	1-259-474-11	CARBON	82K 5% 1/6W	R523	1-249-432-11	CARBON	18K 5% 1/4W
R287	1-249-962-11	CARBON	43K 1% 1/4W	R524	1-249-433-11	CARBON	22K 5% 1/4W
R288	1-249-531-11	CARBON	130 5% 1/4W	R525	1-259-436-11	CARBON	2.2K 5% 1/6W
R290	1-247-701-11	CARBON	120 5% 1/4W F	R526	1-259-436-11	CARBON	2.2K 5% 1/6W
R291	1-249-462-11	CARBON	22K 5% 1/4W	R527	1-249-437-11	CARBON	47K 5% 1/4W
R292	1-247-721-11	CARBON	4.7K 5% 1/4W F	R528	1-259-436-11	CARBON	2.2K 5% 1/6W
R293	1-247-700-11	CARBON	100 5% 1/4W F	R529	1-259-436-11	CARBON	2.2K 5% 1/6W
R294	1-247-152-00	CARBON	8.2K 5% 1/4W	R530	1-249-465-11	CARBON	47K 5% 1/4W
R295	1-247-721-11	CARBON	4.7K 5% 1/4W F	R532	1-249-425-11	CARBON	4.7K 5% 1/4W F
R296	1-249-429-11	CARBON	10K 5% 1/4W	R533	1-249-437-11	CARBON	47K 5% 1/4W
R297	1-249-429-11	CARBON	10K 5% 1/4W	R534	1-249-425-11	CARBON	4.7K 5% 1/4W F
R298	1-249-429-11	CARBON	10K 5% 1/4W	R550	1-249-437-11	CARBON	47K 5% 1/4W
R299	1-247-718-11	CARBON	2.7K 5% 1/4W F	R551	1-249-437-11	CARBON	47K 5% 1/4W
R301	1-249-439-11	CARBON	68K 5% 1/4W	R552	1-249-421-11	CARBON	2.2K 5% 1/4W F
R302	1-249-426-11	CARBON	5.6K 5% 1/4W	R553	1-249-441-11	CARBON	100K 5% 1/4W
R303	1-247-883-00	CARBON	150K 5% 1/4W	R554	1-249-414-11	CARBON	560 5% 1/4W F
△R304	1-212-857-00	FUSIBLE	10 5% 1/4W F	R555	1-247-830-11	CARBON	910 5% 1/4W
R307	1-247-719-11	CARBON	3.3K 5% 1/4W F	R556	1-249-425-11	CARBON	4.7K 5% 1/4W F
R308	1-249-465-11	CARBON	47K 5% 1/4W	R557	1-249-417-11	CARBON	1K 5% 1/4W F
R309	1-249-963-11	CARBON	47K 1% 1/4W	R558	1-249-421-11	CARBON	2.2K 5% 1/4W F
R310	1-249-465-11	CARBON	47K 5% 1/4W	R560	1-249-433-11	CARBON	22K 5% 1/4W
R401	1-249-439-11	CARBON	68K 5% 1/4W	R561	1-249-427-11	CARBON	6.8K 5% 1/4W F
R402	1-249-426-11	CARBON	5.6K 5% 1/4W	R562	1-249-440-11	CARBON	82K 5% 1/4W
R403	1-247-883-00	CARBON	150K 5% 1/4W	R563	1-249-440-11	CARBON	82K 5% 1/4W
△R404	1-212-857-00	FUSIBLE	10 5% 1/4W F	△R564	1-212-853-00	FUSIBLE	6.8 5% 1/4W F
R407	1-247-719-11	CARBON	3.3K 5% 1/4W F	△R565	1-212-853-00	FUSIBLE	6.8 5% 1/4W F
R408	1-249-465-11	CARBON	47K 5% 1/4W	R566	1-249-381-11	CARBON	1 5% 1/4W F
R409	1-249-963-11	CARBON	47K 1% 1/4W	R567	1-249-437-11	CARBON	47K 5% 1/4W
R410	1-249-465-11	CARBON	47K 5% 1/4W	R568	1-215-472-00	METAL	130K 1% 1/4W
R501	1-247-704-11	CARBON	220 5% 1/4W F	R569	1-249-429-11	CARBON	10K 5% 1/4W
R502	1-247-704-11	CARBON	220 5% 1/4W F	R570	1-249-429-11	CARBON	10K 5% 1/4W
R503	1-247-717-11	CARBON	2.2K 5% 1/4W F	R571	1-249-437-11	CARBON	47K 5% 1/4W
R504	1-247-717-11	CARBON	2.2K 5% 1/4W F	R572	1-249-437-11	CARBON	47K 5% 1/4W
R505	1-247-717-11	CARBON	2.2K 5% 1/4W F	R573	1-249-425-11	CARBON	4.7K 5% 1/4W F
R506	1-249-437-11	CARBON	47K 5% 1/4W	< VARIABLE RESISTOR >			
R507	1-247-706-11	CARBON	330 5% 1/4W F	RV101	1-228-991-00	RES, ADJ, METAL 2.2K	
R508	1-249-926-11	CARBON	1.3K 5% 1/4W	RV103	1-228-993-00	RES, ADJ, METAL 4.7K	
R509	1-249-556-11	CARBON	1.5K 5% 1/4W	RV104	1-241-765-11	RES, ADJ, CARBON 22K	
R510	1-249-556-11	CARBON	1.5K 5% 1/4W	RV105	1-241-763-11	RES, ADJ, CARBON 4.7K	
R511	1-249-425-11	CARBON	4.7K 5% 1/4W F	RV201	1-228-991-00	RES, ADJ, METAL 2.2K	
R512	1-249-437-11	CARBON	47K 5% 1/4W	RV203	1-228-993-00	RES, ADJ, METAL 4.7K	
R514	1-249-429-11	CARBON	10K 5% 1/4W	RV204	1-241-765-11	RES, ADJ, CARBON 22K	
R515	1-215-472-00	METAL	130K 1% 1/4W	RV205	1-241-763-11	RES, ADJ, CARBON 4.7K	
R516	1-249-429-11	CARBON	10K 5% 1/4W	RV501	1-230-344-11	RES, VAR, CARBON 20K/20K (REC LEVEL)	
R517	1-249-441-11	CARBON	100K 5% 1/4W	RV504	1-223-797-11	RES, VAR, CARBON 20K/20K (LEVEL)	
R518	1-249-417-11	CARBON	1K 5% 1/4W F				

The components identified by mark  $\Delta$  or dotted line with mark  $\Delta$  are critical for safety. Replace only with part number specified.

Les composants identifiés par une marque  $\Delta$  sont critiques pour la sécurité. Ne les remplacer que par une pièce portant le numéro spécifié.

**AUDIO**

**CAPSTAN C.O.C**

**COMPARATOR**

**MD**

Ref. No.	Part No.	Description	Remark	Ref. No.	Part No.	Description	Remark
RV505	1-238-019-11	RES, ADJ, CARBON 47K		*	1-632-746-11	COMPARATOR BOARD	
RV506	1-241-763-11	RES, ADJ, CARBON 4.7K				*****	
		< TRANSFORMER >				< CAPACITOR >	
T101	1-433-379-11	TRANSFORMER, BIAS OSCILLATOR		C951	1-136-157-00	FILM 0.022uF 5%	50V
T201	1-433-379-11	TRANSFORMER, BIAS OSCILLATOR		C952	1-124-282-00	ELECT 22uF 20%	25V
T501	1-433-359-11	TRANSFORMER, BIAS OSCILLATION		C953	1-124-478-11	ELECT 100uF 20%	25V
		< TEST PIN >		C954	1-124-477-11	ELECT 47uF 20%	25V
* TP501	1-564-506-11	PLUG, CONNECTOR 3P		C955	1-162-203-31	CERAMIC 15PF 5%	50V
* TP502	1-564-505-11	PLUG, CONNECTOR 2P		C956	1-162-203-31	CERAMIC 15PF 5%	50V
		*****		C957	1-136-159-00	FILM 0.033uF 5%	50V
		< CAPACITOR >				< CONNECTOR >	
* A-2006-380-A	CAPSTAN C.O.C BOARD, COMPLETE			* CN951	1-564-718-11	PIN, CONNECTOR (SMALL TYPE) 2P	
		*****		* CN952	1-564-518-11	PLUG, CONNECTOR 3P	
		< CAPACITOR >				< IC >	
C905	1-124-779-00	ELECT CHIP 10uF 20% 16V		IC951	8-759-145-58	IC uPC4558C	
C906	1-135-091-00	TANTALUM CHIP 1uF 20% 16V		IC952	8-759-201-58	IC TC9142P	
C907	1-163-077-91	CERAMIC CHIP 0.1uF 50V				< RESISTOR >	
C908	1-163-077-91	CERAMIC CHIP 0.1uF 50V		R951	1-249-413-11	CARBON 470 5% 1/4W F	
C909	1-163-077-91	CERAMIC CHIP 0.1uF 50V		R952	1-249-413-11	CARBON 470 5% 1/4W F	
C910	1-163-205-00	CERAMIC CHIP 0.001uF 5% 50V		R953	1-247-881-00	CARBON 120K 5% 1/4W	
C911	1-124-779-00	ELECT CHIP 10uF 20% 16V		R954	1-247-881-00	CARBON 120K 5% 1/4W	
		< HALL ELEMENT >		R955	1-249-429-11	CARBON 10K 5% 1/4W	
H901	8-759-100-96	IC uPC4558G2		R956	1-249-417-11	CARBON 1K 5% 1/4W F	
H902	8-759-100-96	IC uPC4558G2		R957	1-249-417-11	CARBON 1K 5% 1/4W F	
H903	8-759-100-96	IC uPC4558G2		R958	1-247-891-00	CARBON 330K 5% 1/4W	
		< IC >		R959	1-247-901-11	CARBON 820K 5% 1/4W	
IC902	8-752-064-50	IC CX20174-T6		R960	1-249-441-11	CARBON 100K 5% 1/4W	
		< RESISTOR >				< VIBRATOR >	
R907	1-216-242-91	METAL GLAZE 68K 5% 1/8W		X951	1-760-560-11	VIBRATOR, CRYSTAL (4.9406MHz)	
R908	1-216-246-91	METAL GLAZE 100K 5% 1/8W				*****	
R909	1-216-242-91	METAL GLAZE 68K 5% 1/8W		* 1-632-740-11	MD BOARD		
R910	1-216-238-91	METAL GLAZE 47K 5% 1/8W			*****		
R911	1-216-182-00	METAL GLAZE 220 5% 1/8W				3-356-631-01	HOLDER (SENSOR)
R912	1-216-182-00	METAL GLAZE 220 5% 1/8W				< CONNECTOR >	
R913	1-216-150-00	METAL GLAZE 10 5% 1/8W		CN1001	1-506-615-11	PIN, CONNECTOR 9P	
R914	1-216-150-00	METAL GLAZE 10 5% 1/8W		CN1002	1-564-501-11	PIN, CONNECTOR 8P	
R915	1-216-150-00	METAL GLAZE 10 5% 1/8W				< IC >	
		*****		IC1001	8-749-920-97	IC GP2S22B	
				IC1002	8-749-920-97	IC GP2S22B	

# MD REEL MOTOR SYSTEM CONTROL

Consisting the following section in the system control (SYSTEM CONTROL (A)/(B)/(C)/(D)/(E)/(F))

Ref. No.	Part No.	Description	Remark
< RESISTOR >			
R1001	1-249-408-11	CARBON	180 5% 1/4W F
R1002	1-249-408-11	CARBON	180 5% 1/4W F
< SWITCH >			
S1002	1-570-953-11	SWITCH, PUSH (1 KEY) (DOOR)	
S1003	1-571-958-11	SWITCH, PUSH (1 KEY) (CLOSE)	
S1004	1-572-126-11	SWITCH, PUSH (1 KEY) (OPEN)	
S1005	1-572-125-11	SWITCH, LEAF (FWD TAB)	
S1006	1-572-202-11	SWITCH, LEAF (HALF)	
S1007	1-572-125-11	SWITCH, LEAF (METAL)	
S1008	1-572-125-11	SWITCH, LEAF (70u)	
< TERMINAL >			
* TB1001	1-694-018-11	TERMINAL (5P)	
*****			
*	1-632-741-11	REEL MOTOR BOARD	*****
< CAPACITOR >			
C1051	1-124-907-11	ELECT	10uF 20% 50V
C1052	1-124-907-11	ELECT	10uF 20% 50V
C1053	1-164-159-11	CERAMIC	0.1uF 50V
< CONNECTOR >			
* CN1051	1-564-499-11	PIN, CONNECTOR 6P	
* CN1052	1-564-718-11	PIN, CONNECTOR (SMALL TYPE) 2P	
* CN1053	1-564-718-11	PIN, CONNECTOR (SMALL TYPE) 2P	
< RESISTOR >			
R1051	1-249-412-11	CARBON	390 5% 1/4W F
*****			
*	A-2007-396-A	SYSTEM CONTROL BOARD, COMPLETE (E)	*****
*	A-2007-398-A	SYSTEM CONTROL BOARD, COMPLETE (US, CND)	*****
		(Including SYSTEM CONTROL (A)/(B)/(C)/(D)/(E)/(F))	
*	1-533-213-31	HOLDER, FUSE	
*	3-309-144-21	HEAT SINK	
*	3-354-927-21	CUSHION	
*	3-356-925-01	HEAT SINK	
*	3-362-478-31	HOLDER (T), LED	
*	3-385-607-01	HOLDER, FL TUBE	
*	4-880-403-11	HEAT SINK	
*	4-942-204-01	PLATE, GROUND	

Ref. No.	Part No.	Description	Remark
< CAPACITOR >			
C320	1-126-962-11	ELECT	3.3uF 20% 50V
C321	1-124-916-11	ELECT	22uF 20% 63V
C322	1-130-478-00	MYLAR	0.0039uF 5% 50V
C323	1-130-482-00	MYLAR	0.0082uF 5% 50V
C324	1-130-485-00	MYLAR	0.015uF 5% 50V
C325	1-130-478-00	MYLAR	0.0039uF 5% 50V
C326	1-130-482-00	MYLAR	0.0082uF 5% 50V
C327	1-130-485-00	MYLAR	0.015uF 5% 50V
C328	1-126-059-11	ELECT	10uF 20% 50V
C420	1-126-962-11	ELECT	3.3uF 20% 50V
C421	1-124-916-11	ELECT	22uF 20% 63V
C422	1-130-478-00	MYLAR	0.0039uF 5% 50V
C423	1-130-482-00	MYLAR	0.0082uF 5% 50V
C424	1-130-485-00	MYLAR	0.015uF 5% 50V
C425	1-130-478-00	MYLAR	0.0039uF 5% 50V
C426	1-130-482-00	MYLAR	0.0082uF 5% 50V
C427	1-130-485-00	MYLAR	0.015uF 5% 50V
C428	1-126-059-11	ELECT	10uF 20% 50V
C550	1-126-059-11	ELECT	10uF 20% 50V
C551	1-126-059-11	ELECT	10uF 20% 50V
C552	1-130-471-00	MYLAR	0.001uF 5% 50V
C553	1-130-471-00	MYLAR	0.001uF 5% 50V
C554	1-130-477-00	MYLAR	0.0033uF 5% 50V
C555	1-130-477-00	MYLAR	0.0033uF 5% 50V
C556	1-136-157-00	FILM	0.022uF 5% 50V
C557	1-136-157-00	FILM	0.022uF 5% 50V
C558	1-124-925-11	ELECT	2.2uF 20% 100V
C559	1-130-467-00	MYLAR	470PF 5% 50V
C560	1-130-467-00	MYLAR	470PF 5% 50V
C561	1-130-476-00	MYLAR	0.0027uF 5% 50V
C562	1-130-476-00	MYLAR	0.0027uF 5% 50V
C563	1-130-472-00	MYLAR	0.0012uF 5% 50V
C564	1-130-472-00	MYLAR	0.0012uF 5% 50V
C565	1-130-472-00	MYLAR	0.0012uF 5% 50V
C566	1-130-472-00	MYLAR	0.0012uF 5% 50V
C567	1-124-925-11	ELECT	2.2uF 20% 100V
C568	1-124-907-11	ELECT	10uF 20% 50V
C569	1-124-907-11	ELECT	10uF 20% 50V
C601	1-164-159-11	CERAMIC	0.1uF 50V
C602	1-164-159-11	CERAMIC	0.1uF 50V
C603	1-124-477-11	ELECT	47uF 20% 25V
C604	1-164-159-11	CERAMIC	0.1uF 50V
C605	1-164-159-11	CERAMIC	0.1uF 50V
C606	1-164-159-11	CERAMIC	0.1uF 50V
△C701	1-161-744-51	CERAMIC	0.01uF 400V
C702	1-136-165-00	FILM	0.1uF 5% 50V
C703	1-136-177-00	FILM	1uF 5% 50V
C704	1-104-644-11	ELECT	3300uF 20% 35V
C705	1-104-644-11	ELECT	3300uF 20% 35V

The components identified by mark  $\Delta$  or dotted line with mark  $\Delta$  are critical for safety. Replace only with part number specified.

Les composants identifiés par une marque  $\Delta$  sont critiques pour la sécurité. Ne les remplacer que par une pièce portant le numéro spécifié.

# SYSTEM CONTROL

Ref. No.	Part No.	Description	Remark	Ref. No.	Part No.	Description	Remark
C706	1-126-972-11	ELECT	1000uF 20% 35V	* CN807	1-564-340-00	PIN, CONNECTOR 6P	
C707	1-126-937-11	ELECT	4700uF 20% 16V	CN810	1-506-469-11	PIN, CONNECTOR 4P	
C708	1-124-122-11	ELECT	100uF 20% 50V	CNP501	1-764-810-11	CONNECTOR, BOARD TO BOARD 8P	
C709	1-162-294-31	CERAMIC	0.001uF 10% 50V	* CNP511	1-568-935-11	PIN, CONNECTOR 8P	
C710	1-162-294-31	CERAMIC	0.001uF 10% 50V	* CNP803	1-568-954-11	PIN, CONNECTOR 5P	
C711	1-109-889-11	ELECT	1uF 20% 50V	* CNP804	1-568-955-11	PIN, CONNECTOR 6P	
C752	1-126-946-11	ELECT	6800uF 20% 25V	< COMPOSITION CIRCUIT BLOCK >			
C755	1-126-963-11	ELECT	4.7uF 20% 50V	CP801	1-236-984-11	COMPOSITION CIRCUIT BLOCK 4.75X11	
C756	1-124-556-11	ELECT	2200uF 20% 16V	CP802	1-239-822-11	COMPOSITION CIRCUIT BLOCK 100KX5	
C757	1-126-963-11	ELECT	4.7uF 20% 50V	CP803	1-236-984-11	COMPOSITION CIRCUIT BLOCK 4.7KX11	
C758	1-126-963-11	ELECT	4.7uF 20% 50V	CP851	1-239-598-11	COMPOSITION CIRCUIT BLOCK 100KX8	
C759	1-162-211-31	CERAMIC	33PF 5% 50V	CP852	1-233-252-11	COMPOSITION CIRCUIT BLOCK 100JX4	
C760	1-126-942-61	ELECT	1000uF 20% 16V	CP853	1-233-267-11	COMPOSITION CIRCUIT BLOCK 15KX6	
C761	1-124-903-11	ELECT	1uF 20% 50V	CP854	1-233-266-11	COMPOSITION CIRCUIT BLOCK 15KX5	
C762	1-124-471-00	ELECT	1000uF 20% 6.3V	< DIODE >			
C765	1-124-907-11	ELECT	10uF 20% 50V	D120	8-719-000-54	DIODE UZL-6L3	
C766	1-124-122-11	ELECT	100uF 20% 50V	D121	8-719-987-63	DIODE 1N4148M	
C767	1-104-664-11	ELECT	47uF 20% 10V	D122	8-719-987-63	DIODE 1N4148M	
C768	1-126-963-11	ELECT	4.7uF 20% 50V	D220	8-719-000-54	DIODE UZL-6L3	
C769	1-124-925-11	ELECT	2.2uF 20% 100V	D221	8-719-987-63	DIODE 1N4148M	
C801	1-124-443-00	ELECT	100uF 20% 10V	D222	8-719-987-63	DIODE 1N4148M	
C802	1-162-294-31	CERAMIC	0.001uF 10% 50V	D514	8-719-987-63	DIODE 1N4148M	
C803	1-126-941-11	ELECT	470uF 20% 6.3V	D515	8-719-987-63	DIODE 1N4148M	
C804	1-164-159-11	CERAMIC	0.1uF 50V	D601	8-719-987-63	DIODE 1N4148M	
C805	1-161-379-00	CERAMIC	0.01uF 20% 25V	D602	8-719-987-63	DIODE 1N4148M	
C811	1-162-294-31	CERAMIC	0.001uF 10% 50V	D603	8-719-987-63	DIODE 1N4148M	
C812	1-162-294-31	CERAMIC	0.001uF 10% 50V	D604	8-719-987-63	DIODE 1N4148M	
C851	1-124-584-00	ELECT	100uF 20% 10V	D701	8-719-230-02	DIODE 30DF2	
C852	1-164-159-11	CERAMIC	0.1uF 50V	D702	8-719-230-02	DIODE 30DF2	
C853	1-164-159-11	CERAMIC	0.1uF 50V	D703	8-719-230-02	DIODE 30DF2	
C854	1-164-159-11	CERAMIC	0.1uF 50V	D704	8-719-230-02	DIODE 30DF2	
C855	1-164-159-11	CERAMIC	0.1uF 50V	D705	8-719-200-77	DIODE 10E2N	
C856	1-162-294-31	CERAMIC	0.001uF 10% 50V	D706	8-719-200-77	DIODE 10E2N	
C857	1-162-294-31	CERAMIC	0.001uF 10% 50V	D707	8-719-200-77	DIODE 10E2N	
C858	1-162-294-31	CERAMIC	0.001uF 10% 50V	D708	8-719-200-77	DIODE 10E2N	
C859	1-164-159-11	CERAMIC	0.1uF 50V	D709	8-719-200-77	DIODE 10E2N	
C891	1-124-234-00	ELECT	22uF 20% 16V	D710	8-719-987-63	DIODE 1N4148M	
< CONNECTOR >				D751	8-719-200-77	DIODE 10E2N	
* CN701	1-580-230-31	PIN, CONNECTOR (PC BOARD) 2P		D752	8-719-001-79	DIODE UZL-12H1	
CN702	1-568-226-11	PIN, CONNECTOR 2P		D753	8-719-933-41	DIODE HZS6C3L	
CN703	1-564-506-11	PLUG, CONNECTOR 3P		D754	8-719-933-36	DIODE HZS6B1L	
CN704	1-564-511-11	PLUG, CONNECTOR 8P		D756	8-719-002-48	DIODE UZL-27H	
* CN801	1-568-937-11	PIN, CONNECTOR 10P		D757	8-719-200-77	DIODE 10E2N	
* CN802	1-568-934-11	PIN, CONNECTOR 7P		D758	8-719-933-41	DIODE HZS6C3L	
* CN803	1-568-954-11	PIN, CONNECTOR 5P		D801	8-719-987-63	DIODE 1N4148M	
* CN804	1-568-955-11	PIN, CONNECTOR 6P		D851	8-719-301-44	LED SEL2410E-D (PLAY)	
* CN805	1-564-342-11	PIN, CONNECTOR 8P		D852	8-719-301-61	DIODE SEL2910A-D (PAUSE)	
* CN806	1-506-503-11	PIN, CONNECTOR 9P		D853	8-719-301-39	LED SEL2210S-D (REC)	



# SYSTEM CONTROL

Ref. No.	Part No.	Description	Remark	Ref. No.	Part No.	Description	Remark
D854	8-719-987-63	DIODE	IN4148M	Q404	8-729-620-05	TRANSISTOR	2SC2603-EF
D855	8-719-987-63	DIODE	IN4148M	Q405	8-729-620-05	TRANSISTOR	2SC2603-EF
D856	8-719-987-63	DIODE	IN4148M	Q406	8-729-620-05	TRANSISTOR	2SC2603-EF
		< FUSE >		Q407	8-729-620-05	TRANSISTOR	2SC2603-EF
△F701	1-532-285-00	FUSE, TIME-LAG (T1. 25A/250V) (E)		Q408	8-729-620-05	TRANSISTOR	2SC2603-EF
△F701	1-532-741-11	FUSE, GLASS TUBE (1. 25A/125V) (US, CND)		Q409	8-729-620-05	TRANSISTOR	2SC2603-EF
		< FLUORESCENT INDICATOR >		Q410	8-729-620-05	TRANSISTOR	2SC2603-EF
FLT851	1-517-359-11	INDICATOR TUBE, FLUORESCENT		Q411	8-729-620-05	TRANSISTOR	2SC2603-EF
		< IC >		Q601	8-729-900-89	TRANSISTOR	DTC144ES
IC520	8-759-634-51	IC	M5218AP	Q602	8-729-900-89	TRANSISTOR	DTC144ES
IC521	8-759-634-51	IC	M5218AP	Q603	8-729-900-89	TRANSISTOR	DTC144ES
IC522	8-759-634-51	IC	M5218AP	Q604	8-729-900-65	TRANSISTOR	DTA144ES
IC523	8-759-634-51	IC	M5218AP	Q605	8-729-900-65	TRANSISTOR	DTA144ES
IC524	8-759-711-35	IC	NJM4580D	Q606	8-729-119-76	TRANSISTOR	2SA1175-HFE
IC525	8-759-711-35	IC	NJM4580D	Q607	8-729-140-97	TRANSISTOR	2SB734-34
IC601	8-759-973-95	IC	BA6219B	Q608	8-729-119-76	TRANSISTOR	2SA1175-HFE
IC602	8-759-822-09	IC	LB1641	Q701	8-729-620-05	TRANSISTOR	2SC2603-EF
IC603	8-759-505-55	IC	NJM4558L	Q751	8-729-209-15	TRANSISTOR	2SD2012
IC751	8-759-165-85	IC	PST600H-T	Q752	8-729-209-15	TRANSISTOR	2SD2012
IC801	8-759-331-29	IC	M38172M4-133FP	Q753	8-729-141-83	TRANSISTOR	2SB1094-LK
IC802	8-759-248-66	IC	AT24C01-10PC	Q755	8-729-140-97	TRANSISTOR	2SB734-34
IC851	8-759-291-05	IC	M38122M2-069SP	Q756	8-729-620-05	TRANSISTOR	2SC2603-EF
IC891	8-741-810-59	IC	SBX1810-59	Q757	8-729-620-05	TRANSISTOR	2SC2603-EF
IC901	8-759-634-51	IC	M5218AP	Q758	8-729-620-05	TRANSISTOR	2SC2603-EF
IC902	8-759-634-51	IC	M5218AP	Q759	8-729-620-05	TRANSISTOR	2SC2603-EF
		< PILOT LAMP >		Q801	8-729-900-65	TRANSISTOR	DTA144ES
PL901	1-518-471-31	LAMP, PILOT		Q802	8-729-900-65	TRANSISTOR	DTA144ES
PL902	1-518-471-31	LAMP, PILOT		Q803	8-729-900-89	TRANSISTOR	DTC144ES
PL903	1-518-471-31	LAMP, PILOT		Q851	8-729-900-61	TRANSISTOR	DTA114ES
		< TRANSISTOR >		Q852	8-729-900-61	TRANSISTOR	DTA114ES
Q301	8-729-620-05	TRANSISTOR	2SC2603-EF	Q853	8-729-900-61	TRANSISTOR	DTA114ES
Q302	8-729-620-05	TRANSISTOR	2SC2603-EF	Q854	8-729-900-61	TRANSISTOR	DTA114ES
Q303	8-729-620-05	TRANSISTOR	2SC2603-EF	Q901	8-729-922-37	TRANSISTOR	2SD2144S-UVW
Q304	8-729-620-05	TRANSISTOR	2SC2603-EF	Q902	8-729-922-37	TRANSISTOR	2SD2144S-UVW
Q305	8-729-620-05	TRANSISTOR	2SC2603-EF	Q903	8-729-922-37	TRANSISTOR	2SD2144S-UVW
Q306	8-729-620-05	TRANSISTOR	2SC2603-EF	Q904	8-729-922-37	TRANSISTOR	2SD2144S-UVW
Q307	8-729-620-05	TRANSISTOR	2SC2603-EF			< RESISTOR >	
Q308	8-729-620-05	TRANSISTOR	2SC2603-EF	R320	1-215-465-00	METAL	68K 1% 1/4W
Q309	8-729-620-05	TRANSISTOR	2SC2603-EF	R321	1-215-448-00	METAL	13K 1% 1/4W
Q310	8-729-620-05	TRANSISTOR	2SC2603-EF	R322	1-215-403-00	METAL	180 1% 1/4W
Q311	8-729-620-05	TRANSISTOR	2SC2603-EF	R323	1-215-473-00	METAL	150K 1% 1/4W
Q401	8-729-620-05	TRANSISTOR	2SC2603-EF	R324	1-215-471-00	METAL	120K 1% 1/4W
Q402	8-729-620-05	TRANSISTOR	2SC2603-EF	R330	1-249-971-11	CARBON	100K 1% 1/4W
Q403	8-729-620-05	TRANSISTOR	2SC2603-EF	R331	1-249-971-11	CARBON	100K 1% 1/4W
				R332	1-249-930-11	CARBON	2K 1% 1/4W
				R333	1-249-971-11	CARBON	100K 1% 1/4W
				R334	1-249-961-11	CARBON	39K 1% 1/4W
				R335	1-249-954-11	CARBON	20K 1% 1/4W
				R336	1-249-947-11	CARBON	10K 1% 1/4W

The components identified by mark $\Delta$ or dotted line with mark $\Delta$ are critical for safety. Replace only with part number specified.	Les composants identifiés par une marque $\Delta$ sont critiques pour la sécurité. Ne les remplacer que par une pièce portant le numéro spécifié.
--	---

# SYSTEM CONTROL

Ref. No.	Part No.	Description	Remark	Ref. No.	Part No.	Description	Remark
R337	1-249-930-11	CARBON	2K 1% 1/4W	R446	1-247-891-00	CARBON	330K 5% 1/4W
R338	1-249-961-11	CARBON	39K 1% 1/4W	R447	1-249-429-11	CARBON	10K 5% 1/4W
R339	1-249-954-11	CARBON	20K 1% 1/4W	R448	1-249-429-11	CARBON	10K 5% 1/4W
R340	1-249-947-11	CARBON	10K 1% 1/4W	R449	1-249-429-11	CARBON	10K 5% 1/4W
R341	1-247-891-00	CARBON	330K 5% 1/4W	R450	1-249-429-11	CARBON	10K 5% 1/4W
R342	1-247-891-00	CARBON	330K 5% 1/4W	R451	1-249-429-11	CARBON	10K 5% 1/4W
R343	1-247-891-00	CARBON	330K 5% 1/4W	R452	1-249-429-11	CARBON	10K 5% 1/4W
R344	1-247-891-00	CARBON	330K 5% 1/4W	R455	1-249-917-11	CARBON	560 1% 1/4W
R345	1-247-891-00	CARBON	330K 5% 1/4W	R456	1-249-952-11	CARBON	16K 1% 1/4W
R346	1-247-891-00	CARBON	330K 5% 1/4W	R457	1-249-945-11	CARBON	8.2K 1% 1/4W
R347	1-249-429-11	CARBON	10K 5% 1/4W	R458	1-249-937-11	CARBON	3.9K 1% 1/4W F
R348	1-249-429-11	CARBON	10K 5% 1/4W	R459	1-249-930-11	CARBON	2K 1% 1/4W
R349	1-249-429-11	CARBON	10K 5% 1/4W	R460	1-249-923-11	CARBON	1K 1% 1/4W
R350	1-249-429-11	CARBON	10K 5% 1/4W	R461	1-249-429-11	CARBON	10K 5% 1/4W
R351	1-249-429-11	CARBON	10K 5% 1/4W	R462	1-249-429-11	CARBON	10K 5% 1/4W
R352	1-249-429-11	CARBON	10K 5% 1/4W	R463	1-249-429-11	CARBON	10K 5% 1/4W
R355	1-249-917-11	CARBON	560 1% 1/4W	R464	1-249-429-11	CARBON	10K 5% 1/4W
R356	1-249-952-11	CARBON	16K 1% 1/4W	R465	1-249-429-11	CARBON	10K 5% 1/4W
R357	1-249-945-11	CARBON	8.2K 1% 1/4W	R466	1-249-461-11	CARBON	18K 5% 1/4W
R358	1-249-937-11	CARBON	3.9K 1% 1/4W F	R467	1-249-971-11	CARBON	100K 1% 1/4W
R359	1-249-930-11	CARBON	2K 1% 1/4W	R601	1-249-429-11	CARBON	10K 5% 1/4W
R360	1-249-923-11	CARBON	1K 1% 1/4W	R602	1-249-426-11	CARBON	5.6K 5% 1/4W
R361	1-249-429-11	CARBON	10K 5% 1/4W	R603	1-249-413-11	CARBON	470 5% 1/4W F
R362	1-249-429-11	CARBON	10K 5% 1/4W	R604	1-249-429-11	CARBON	10K 5% 1/4W
R363	1-249-429-11	CARBON	10K 5% 1/4W	R605	1-249-429-11	CARBON	10K 5% 1/4W
R364	1-249-429-11	CARBON	10K 5% 1/4W	△R606	1-212-934-00	FUSIBLE	1 5% 1/2W F
R365	1-249-429-11	CARBON	10K 5% 1/4W	R607	1-249-421-11	CARBON	2.2K 5% 1/4W F
R366	1-249-461-11	CARBON	18K 5% 1/4W	R608	1-249-421-11	CARBON	2.2K 5% 1/4W F
R367	1-249-971-11	CARBON	100K 1% 1/4W	R609	1-249-426-11	CARBON	5.6K 5% 1/4W
R420	1-215-465-00	METAL	68K 1% 1/4W	R610	1-249-423-11	CARBON	3.3K 5% 1/4W F
R421	1-215-448-00	METAL	13K 1% 1/4W	R611	1-247-807-31	CARBON	100 5% 1/4W
R422	1-215-403-00	METAL	180 1% 1/4W	R612	1-249-419-11	CARBON	1.5K 5% 1/4W F
R423	1-215-473-00	METAL	150K 1% 1/4W	R613	1-247-807-31	CARBON	100 5% 1/4W
R424	1-215-471-00	METAL	120K 1% 1/4W	R614	1-247-807-31	CARBON	100 5% 1/4W
R430	1-249-971-11	CARBON	100K 1% 1/4W	R615	1-249-428-11	CARBON	8.2K 5% 1/4W F
R431	1-249-971-11	CARBON	100K 1% 1/4W	R616	1-249-427-11	CARBON	6.8K 5% 1/4W F
R432	1-249-930-11	CARBON	2K 1% 1/4W	R617	1-249-428-11	CARBON	8.2K 5% 1/4W F
R433	1-249-971-11	CARBON	100K 1% 1/4W	△R618	1-212-954-11	FUSIBLE	6.8 5% 1/2W F
R434	1-249-961-11	CARBON	39K 1% 1/4W	△R701	1-212-863-00	FUSIBLE	18 5% 1/4W F
R435	1-249-954-11	CARBON	20K 1% 1/4W	R702	1-249-439-11	CARBON	68K 5% 1/4W
R436	1-249-947-11	CARBON	10K 1% 1/4W	R703	1-249-439-11	CARBON	68K 5% 1/4W
R437	1-249-930-11	CARBON	2K 1% 1/4W	R751	1-249-423-11	CARBON	3.3K 5% 1/4W F
R438	1-249-961-11	CARBON	39K 1% 1/4W	R752	1-249-421-11	CARBON	2.2K 5% 1/4W F
R439	1-249-954-11	CARBON	20K 1% 1/4W	R753	1-249-425-11	CARBON	4.7K 5% 1/4W F
R440	1-249-947-11	CARBON	10K 1% 1/4W	R754	1-249-421-11	CARBON	2.2K 5% 1/4W F
R441	1-247-891-00	CARBON	330K 5% 1/4W	R755	1-249-421-11	CARBON	2.2K 5% 1/4W F
R442	1-247-891-00	CARBON	330K 5% 1/4W	R756	1-249-421-11	CARBON	2.2K 5% 1/4W F
R443	1-247-891-00	CARBON	330K 5% 1/4W	R757	1-249-427-11	CARBON	6.8K 5% 1/4W F
R444	1-247-891-00	CARBON	330K 5% 1/4W	R758	1-249-423-11	CARBON	3.3K 5% 1/4W F
R445	1-247-891-00	CARBON	330K 5% 1/4W	R759	1-249-437-11	CARBON	47K 5% 1/4W

<p>The components identified by mark <math>\triangle</math> or dotted line with mark <math>\triangle</math> are critical for safety. Replace only with part number specified.</p>	<p>Les composants identifiés par une marque <math>\triangle</math> sont critiques pour la sécurité. Ne les remplacer que par une pièce portant le numéro spécifié.</p>
---	--

# SYSTEM CONTROL

Ref. No.	Part No.	Description	Remark	Ref. No.	Part No.	Description	Remark
R760	1-249-421-11	CARBON	2.2K 5% 1/4W F	R865	1-249-429-11	CARBON	10K 5% 1/4W
R765	1-249-422-11	CARBON	2.7K 5% 1/4W F	R866	1-249-429-11	CARBON	10K 5% 1/4W
R766	1-249-437-11	CARBON	47K 5% 1/4W	R867	1-249-429-11	CARBON	10K 5% 1/4W
R767	1-249-437-11	CARBON	47K 5% 1/4W	R868	1-249-421-11	CARBON	2.2K 5% 1/4W F
R768	1-249-429-11	CARBON	10K 5% 1/4W	R869	1-249-421-11	CARBON	2.2K 5% 1/4W F
R769	1-247-807-31	CARBON	100 5% 1/4W	R870	1-249-421-11	CARBON	2.2K 5% 1/4W F
R770	1-249-441-11	CARBON	100K 5% 1/4W	R872	1-247-807-31	CARBON	100 5% 1/4W
R771	1-249-441-11	CARBON	100K 5% 1/4W	R875	1-249-423-11	CARBON	3.3K 5% 1/4W F
R772	1-249-417-11	CARBON	1K 5% 1/4W F	R876	1-249-423-11	CARBON	3.3K 5% 1/4W F
R801	1-247-807-31	CARBON	100 5% 1/4W	R877	1-249-423-11	CARBON	3.3K 5% 1/4W F
R802	1-247-807-31	CARBON	100 5% 1/4W	R891	1-249-422-11	CARBON	2.7K 5% 1/4W F
R804	1-247-807-31	CARBON	100 5% 1/4W	R892	1-249-424-11	CARBON	3.9K 5% 1/4W F
R805	1-249-423-11	CARBON	3.3K 5% 1/4W F	R893	1-249-428-11	CARBON	8.2K 5% 1/4W F
R806	1-249-429-11	CARBON	10K 5% 1/4W	R894	1-249-422-11	CARBON	2.7K 5% 1/4W F
R807	1-249-429-11	CARBON	10K 5% 1/4W	R895	1-249-424-11	CARBON	3.9K 5% 1/4W F
R808	1-247-807-31	CARBON	100 5% 1/4W	R896	1-249-428-11	CARBON	8.2K 5% 1/4W F
R809	1-249-429-11	CARBON	10K 5% 1/4W	R897	1-249-429-11	CARBON	10K 5% 1/4W
R810	1-249-436-11	CARBON	39K 5% 1/4W	R901	1-249-433-11	CARBON	22K 5% 1/4W
R811	1-249-436-11	CARBON	39K 5% 1/4W	R902	1-247-856-00	CARBON	11K 5% 1/4W
R812	1-249-421-11	CARBON	2.2K 5% 1/4W F	R903	1-249-397-11	CARBON	22 5% 1/4W F
R813	1-249-429-11	CARBON	10K 5% 1/4W	R904	1-249-406-11	CARBON	120 5% 1/4W F
R814	1-249-429-11	CARBON	10K 5% 1/4W	R905	1-247-856-00	CARBON	11K 5% 1/4W
R815	1-249-429-11	CARBON	10K 5% 1/4W	R906	1-249-433-11	CARBON	22K 5% 1/4W
R816	1-247-807-31	CARBON	100 5% 1/4W	R907	1-247-860-11	CARBON	16K 5% 1/4W
R817	1-247-807-31	CARBON	100 5% 1/4W	R908	1-249-397-11	CARBON	22 5% 1/4W F
R818	1-247-807-31	CARBON	100 5% 1/4W	R909	1-249-406-11	CARBON	120 5% 1/4W F
R819	1-247-807-31	CARBON	100 5% 1/4W	R910	1-247-860-11	CARBON	16K 5% 1/4W
R820	1-247-807-31	CARBON	100 5% 1/4W	R911	1-249-433-11	CARBON	22K 5% 1/4W
R821	1-247-807-31	CARBON	100 5% 1/4W	R912	1-249-432-11	CARBON	18K 5% 1/4W
R822	1-247-807-31	CARBON	100 5% 1/4W	R913	1-249-397-11	CARBON	22 5% 1/4W F
R823	1-247-807-31	CARBON	100 5% 1/4W	R914	1-249-406-11	CARBON	120 5% 1/4W F
R824	1-249-429-11	CARBON	10K 5% 1/4W	R915	1-249-432-11	CARBON	18K 5% 1/4W
R825	1-249-429-11	CARBON	10K 5% 1/4W	R916	1-247-887-00	CARBON	220K 5% 1/4W
R826	1-249-429-11	CARBON	10K 5% 1/4W	R917	1-247-887-00	CARBON	220K 5% 1/4W
R841	1-249-436-11	CARBON	39K 5% 1/4W	R918	1-247-887-00	CARBON	220K 5% 1/4W
R842	1-249-436-11	CARBON	39K 5% 1/4W	R919	1-247-807-31	CARBON	100 5% 1/4W
R851	1-249-422-11	CARBON	2.7K 5% 1/4W F	R920	1-249-417-11	CARBON	1K 5% 1/4W F
R852	1-249-422-11	CARBON	2.7K 5% 1/4W F	R921	1-249-437-11	CARBON	47K 5% 1/4W
R853	1-249-424-11	CARBON	3.9K 5% 1/4W F	R922	1-249-438-11	CARBON	56K 5% 1/4W
R854	1-249-428-11	CARBON	8.2K 5% 1/4W F	R923	1-249-438-11	CARBON	56K 5% 1/4W
R855	1-249-434-11	CARBON	27K 5% 1/4W	R924	1-249-428-11	CARBON	8.2K 5% 1/4W F
R856	1-249-422-11	CARBON	2.7K 5% 1/4W F	R925	1-247-854-11	CARBON	9.1K 5% 1/4W
R857	1-249-424-11	CARBON	3.9K 5% 1/4W F	R926	1-247-854-11	CARBON	9.1K 5% 1/4W
R858	1-249-428-11	CARBON	8.2K 5% 1/4W F	R927	1-247-881-00	CARBON	120K 5% 1/4W
R859	1-249-434-11	CARBON	27K 5% 1/4W	R928	1-247-881-00	CARBON	120K 5% 1/4W
R860	1-249-422-11	CARBON	2.7K 5% 1/4W F	R929	1-249-428-11	CARBON	8.2K 5% 1/4W F
R861	1-249-411-11	CARBON	330 5% 1/4W	R930	1-247-881-00	CARBON	120K 5% 1/4W
R862	1-249-409-11	CARBON	220 5% 1/4W F	R931	1-247-881-00	CARBON	120K 5% 1/4W
R863	1-249-409-11	CARBON	220 5% 1/4W F	R932	1-249-426-11	CARBON	5.6K 5% 1/4W
R864	1-249-429-11	CARBON	10K 5% 1/4W	R933	1-249-430-11	CARBON	12K 5% 1/4W



# TC-KA3ES

<u>Ref. No.</u>	<u>Part No.</u>	<u>Description</u>	<u>Remark</u>
#16	7-682-648-09	SCREW +PS 3X8	
#17	7-621-255-35	SCREW +BVTT 2X5 (S)	
#18	7-685-861-01	SCREW +BVTT 2.6X5 (S)	
#19	7-685-646-79	SCREW +BVTP 3X8 TYPE2 N-S (E)	